

Uponor Ecoflex piping systems

EN Technical information

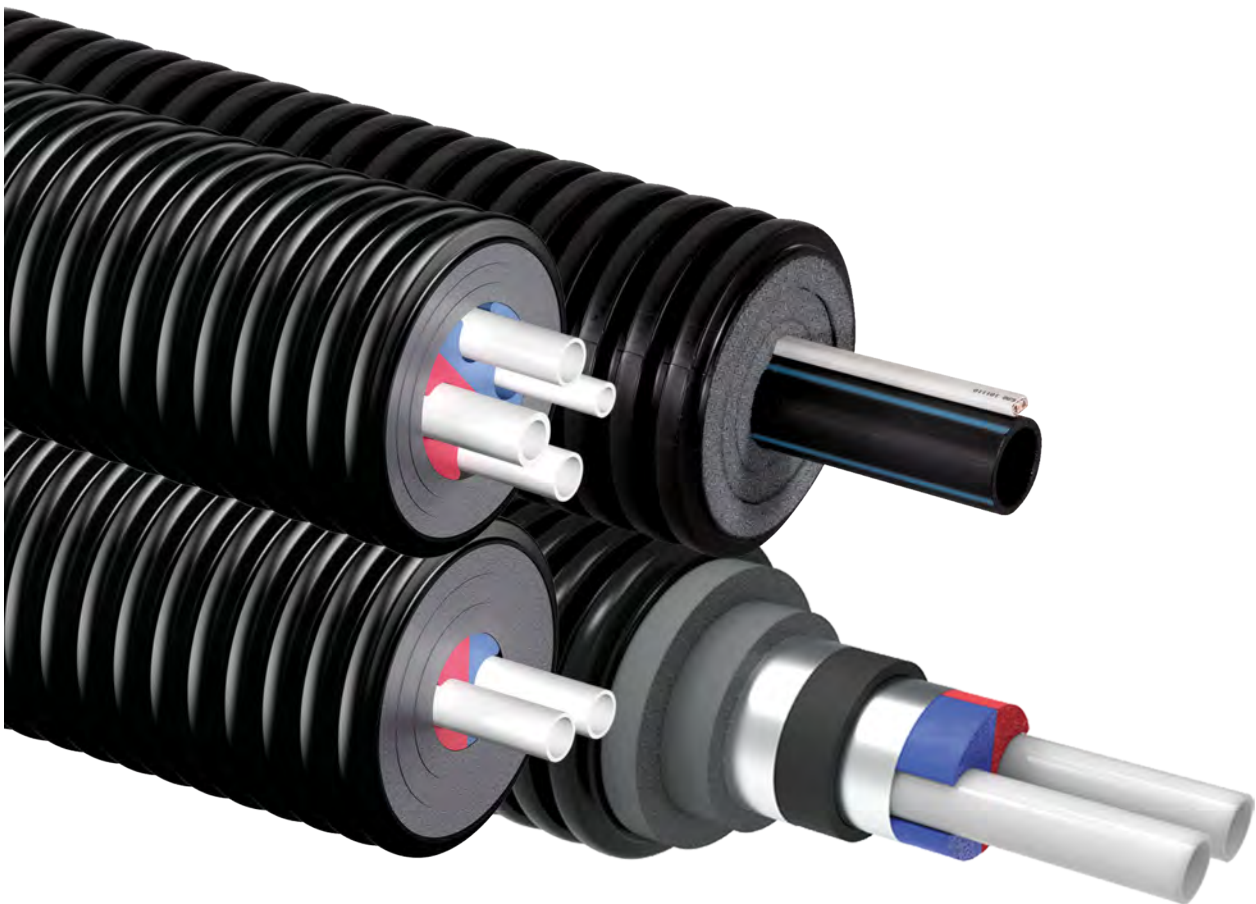

Table of contents

1	System description and fields of use.....	3	6.5	Electrical installations of Ecoflex Supra cables and control units.....	61
1.1	Low-temperature local heating networks.....	3	6.6	Pressure and leak testing.....	62
1.2	Certificates and product standards.....	4			
1.3	Product description.....	4			
2	Uponor Ecoflex pipes.....	6	7	Technical data.....	63
2.1	Pipe overview.....	6	7.1	Uponor PE-Xa pipes.....	63
2.2	Pipe descriptions.....	6	7.2	Classification of service conditions.....	65
2.3	Heating and cooling.....	7	7.3	Uponor PE-HD medium pipes.....	67
2.4	Warm tap water.....	10	7.4	Insulation materials.....	68
2.5	Heating and warm tap water.....	13	7.5	Jacket pipe material.....	68
2.6	Cold water and cooling.....	14	7.6	Electrical components.....	68
3	Uponor Ecoflex components.....	22			
3.1	Uponor Wipex fittings.....	22			
3.2	Uponor Ecoflex fittings.....	22			
3.3	Adapters for Uponor Wipex and Ecoflex fittings.....	22			
3.4	Uponor Q&E fittings.....	23			
3.5	Plastic fittings for Ecoflex Supra pipes.....	23			
3.6	Uponor Ecoflex rubber end caps.....	23			
3.7	Uponor Ecoflex insulation sets.....	24			
3.8	Uponor Ecoflex chamber.....	24			
3.9	Uponor Ecoflex house connection elbow single/twin.....	24			
3.10	Uponor Ecoflex wall ducts.....	25			
3.11	Additional accessories.....	27			
4	Planning/design.....	29			
4.1	Design basics.....	29			
4.2	Planning Ecoflex Supra PLUS.....	30			
4.3	Planning Ecoflex Supra Standard.....	32			
5	Dimensioning.....	35			
5.1	Heating dimensioning diagram.....	35			
5.2	Dimensioning table for heating pipe, PN 6 (SDR 11).....	36			
5.3	Quick dimensioning table heating pipe, PN 10 (SDR 7,4)....	39			
5.4	Heat loss tables.....	41			
5.5	Pressure loss for Ecoflex heating pipes, PN 6 (SDR 11).....	44			
5.6	Pressure loss for Ecoflex warm tap water pipes, PN 10 (SDR 7,4).....	47			
5.7	Pressure loss for Ecoflex Supra, Supra PLUS and Supra Standard pipes PN 16 (SDR 11).....	50			
5.8	Thermal losses for Uponor Ecoflex Supra pipes.....	53			
6	Installation and operation.....	55			
6.1	Average installation times.....	55			
6.2	Installation of pipes, general instructions.....	55			
6.3	Mounting of components and accessories.....	59			
6.4	Installation of Ecoflex Supra Standard and PLUS pipes.....	61			

1 System description and fields of use



RF000020

1.1 Low-temperature local heating networks

With the EU looking into becoming carbon-neutral by 2050 and aiming to limit the global rise in temperature to under 2 °C, climate-friendly and carbon-neutral solutions are important points of focus across all industries. Heating plays an important role in Europe's path to carbon neutrality: more than a third of EU's greenhouse gas emissions originate from building energy use. With central heat generation, low-temperature distribution and flexibility regarding the energy source, local heating networks that are equipped with high-performance pre-insulated pipes constitute a useful approach to making heating more energy-efficient and sustainable.

Local and district heating networks offer many advantages in terms of the buildings' energy efficiency and convenience for the occupants. They are particularly suitable for urban, densely populated areas, and considering 74,3 percent of the European population lives in cities, heating networks offer a promising solution. Consequently, district and local heating networks offer a large potential in improving the climate and energy performance of European communities, especially when they operate on low temperatures.

Pipe system is crucial for heating network's efficiency

The pipe system that connects the buildings lies at the heart of every heating network. Its capacity and insulation performance are crucial factors in the system's overall energy efficiency. Local heating networks usually operate on low temperatures of a maximum of 80 °C, which help to minimize thermal losses. The industry standard for these small and medium-sized local networks are pre-insulated PE-Xa plastic pipes which boast a good thermal loss performance, are durable since they do not corrode, and are flexible and easy to install. This also makes them the ideal solution for renovation purposes, where a part or a whole network needs to be renewed.

Low-temperature local heating networks: the path to energy efficiency

Lower temperatures also extend the plastic pipes' expected lifetime: at an operating temperature of 80 °C, the pipe is expected to last more than 30 years, at 70 °C more than 50 years and at an operating temperature below 60 °C, according to European and international standards the expected lifetime even exceeds 100 years. Together with high-performance pipe systems like Ecoflex VIP with its outstanding insulation performance, low-temperature local heating networks can make an important and positive contribution towards the EU's net-zero goals.

1.2 Certificates and product standards



Uncompromising quality is our number one policy. Fully comprehensive quality control in production is just one aspect of our quality management system. In addition, several independent inspection organisations certify that our products meet the strictest standards.

In accordance with EN Standards

Uponor flexible pre-insulated pipe systems are manufactured according to European Standard "EN 15632 - Part 1 and 3 - District heating - Factory made flexible pipe systems" and "EN 17414 - Part 1 and 3 - District cooling pipes - Factory made flexible pipe systems".

System approvals

Uponor Ecoflex Thermo Single and Twin pipes, the corresponding rubber end caps, Wipex fittings and insulation kits carry a Kiwa KOMO technical approval with product certificate. System approval is according to the current Kiwa Komo BRL5609 guideline, and it certifies a system service life of at least 30 years, as well as absence of leaks at a water pressure of 0,3 bar and an ambient temperature of 30 °C.

In addition, Uponor Ecoflex VIP Thermo, Thermo and Varia pipes with fittings and accessories have CSTB Avis Technique technical approval and product certificate.

Heat loss performance

Heat loss characteristics of Uponor Ecoflex pipes have been defined by CFD (Computational Fluid Dynamics) computer simulation and verified with 3rd party laboratory tests.

Static strength

The ring stiffness of the jacket pipe has been tested according to EN ISO 9969 to be able to withstand 4 kN/m² (class SN4). Selected Uponor Ecoflex flexible pipe systems and components are certified according to ATV DVWK-A127. When installed in accordance with ATV DVWK-A127, these pipes and components are suitable for loading by heavy traffic (SLW 60 = 60 t).



1.3 Product description

Uponor offers an innovative and energy efficient selection of pre-insulated pipes, fittings and accessories. The secure and durable systems are suitable for heating-, cooling-, and water distribution. Whether for buildings or complete local distribution networks, the system combines excellent heat loss performance with high flexibility and easy installation.

The product range for local and district heating networks is based on Uponors strong experience and know-how.

Uponor Ecoflex offers a complete system solution from the energy source to the building. The energy source can be any source of heat, e.g. a power plant, gas boiler, heat pump or district heating sub station.

Wide range of services support our customers in all project phases from training to design, delivery and site support. We are the best partner for our customers with our over 30 years of experience and with more than 35 million meters of pipes installed world wide.

This technical information contains the following product groups:

Insulated pipes

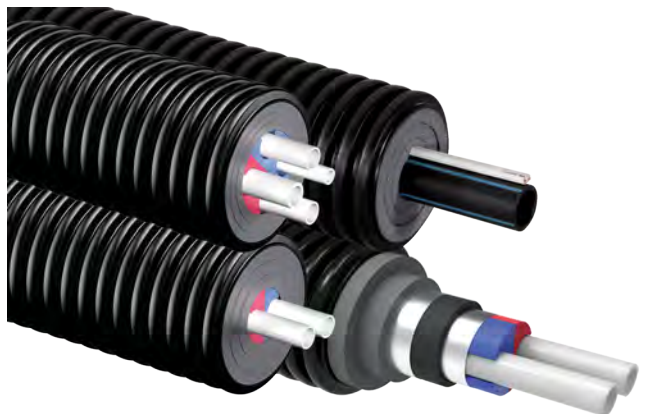

For heating, cooling, warm and cold water distribution, different insulation performance.

Fittings



Wipex fittings from brass and Quick & Easy fitting made from PPSU material.

content of this document. Any rights not expressly granted herein are reserved.

While Uponor has made effort at the time of publication this document to ensure the accuracy of the information provided herein, this information is subject to change without notice. For any questions or queries, please visit Uponor local website or approach your Uponor contact.

Jacket pipe connection sets



Straight piece, elbow, tee insulations and chambers.

Accessories



House entry components, end caps, tools, and all other important elements.

Disclaimer

This is a generic, European-wide document version. The information in this document is provided on an "as is" basis and no warranty of any kind is given in relation thereto.

This document may show products that are not available in your location for technical, legal, commercial or other reasons. Therefore, please check always in advance from the applicable Uponor product or price list whether the products are available in the location and for the time they are intended for.

The design and specifications of the products are subject to change without notice and may vary from those shown. Images displayed are for illustration purposes only. A full compliance with the local regulations, standards or ways of working may not be guaranteed.

The trademark "Uponor" is a registered trademark of Uponor Corporation and Uponor Corporation holds the copyright to the

2 Uponor Ecoflex pipes

2.1 Pipe overview

Uponor offers systems suitable for heating, cooling, warm and cold water distribution.

Heating and cooling

Product names: Uponor Ecoflex VIP Thermo, Thermo and Varia

Fields of use

- Connection of communities and individual large heat consumers to central power plants, woodchip and biomass plants.
- Local networks for the heating and cooling water supply.
- Heating and cooling distribution within industrial and agricultural production plants.
- Heat transfer between single buildings, e.g. from a heat pump placed in a separate technical building or garage.

Warm tap water

Product names: Uponor Ecoflex VIP Aqua, Aqua and Quattro

Fields of use

- Connection of communities or individual buildings to a central warm water boiler.
- Transport of warm tap water between single buildings.
- Warm tap water distribution within industrial and agricultural production plants.
- All-in-one heating and warm tap water supply for single buildings with only one pipe (Ecoflex Quattro).

Cold water and cooling

Product names: Uponor Ecoflex Supra, Supra Plus, Supra Standard, Supra Sewer

Fields of use

- Frost-proof underground transport of cold tap water to single buildings.
- Frost-proof above-ground cold water supply of temporary residential containers on major construction sites with ambient temperatures down to -50 °C.
- Transport of cold tap water or cooling water in industrial production plants.
- Frost proof sewage drainage of buildings in installations where there is a risk of freezing.

2.2 Pipe descriptions

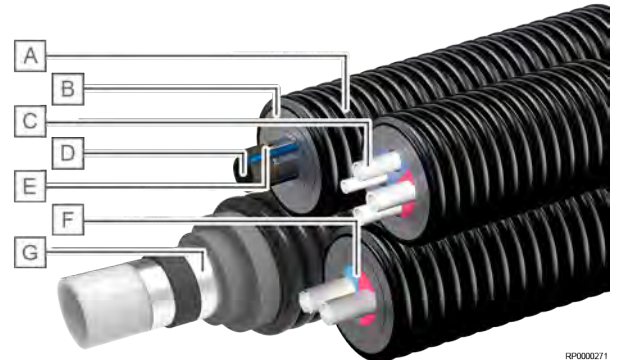

Item	Type	Description
A	Jacket pipe	The PE-HD jacket pipe: the high quality material and the special geometry of the jacket pipe makes Ecoflex pipes extra flexible and highly resistant to static and traffic loads up to 60 tons.
B	Insulation	The insulation made from cross linked polyethylene foam: ideal insulating properties, ageing-resistant, resistance to moisture and very high flexibility.
C	Medium pipe (PE-Xa)	The PE-Xa service pipe is hygienic, temperature resistant and resistant to incrustation and stress cracking. For heating applications coated with an EVOH oxygen barrier to avoid oxygen migration into the system.
D	Medium pipe (PE-HD)	The PE-HD service pipe provides maximum safety and service life in cold water applications up to 16 bar and are resistant against many aggressive media.
E	Heating cable	Heat traced freeze protected Supra family products equipped with heating cable together with insulation guarantee reliable water supply in arctic conditions.
F	Centre profile	The coloured centre profile ensures a clear assignment of the service pipes.
G	VIP	The revolutionary vacuum insulated panel (VIP) with low lambda value of 0,004 W/mK.

2.3 Heating and cooling

Uponor Ecoflex VIP Thermo

Uponor Ecoflex VIP Thermo pipes, produced based on European Standard EN 15632 and EN 17414, are for heating and cooling applications. Single pipes are for projects with large flow requirements. VIP Thermo Twin offers supply and return pipes in one jacket. The pipes have extremely good insulation performance and flexibility.

Application

- Transport of heating and cooling water for buried installations.
- Operating temperature up to 80 °C based on EN 15632.
- Maximum load temperature / pressure: 95 °C / 6 bar.
- Static verification for heavy traffic load of 60 tons.

Type	Description
Jacket pipe	Corrugated polyethylene (HDPE). Ring stiffness SN4 (4 kN/m ²) EN ISO 9969.
PE-X insulation	Permanently elastic closed-cell cross-linked polyethylene (PE-X) foam. Thermal conductivity: $\lambda_{50} = 0,041$ W/mK.
VIP insulation	Vacuum insulated panel. Thermal conductivity: $\lambda_{50} = 0,004$ W/mK.
Centre profile	Coloured blue/red polyethylene centre profile for Twin pipe.
Medium pipe	Cross-linked polyethylene (PE-Xa) pipe based on EN ISO 15875 with EVOH layer, natural colored, PN6 (SDR11)

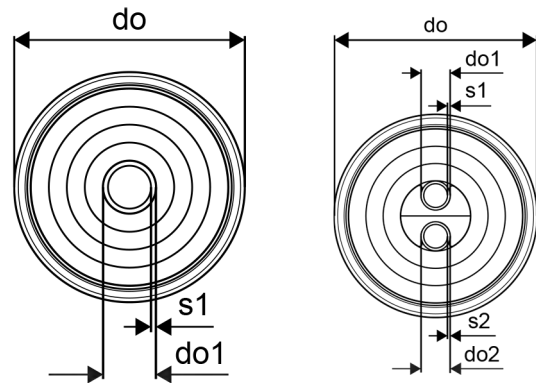
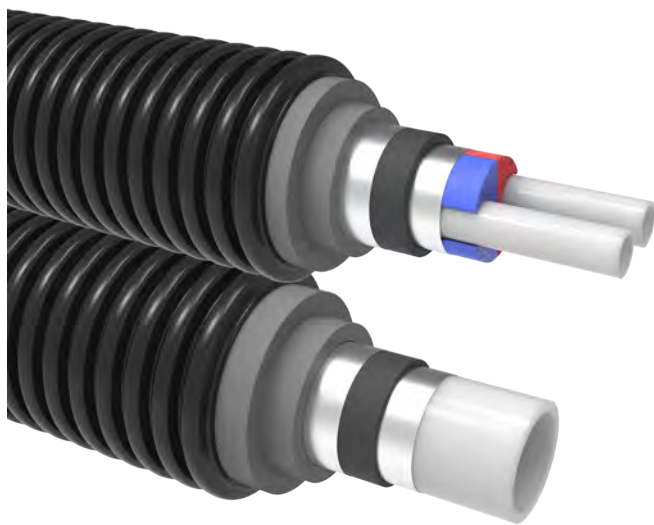

RP0000272

Ecoflex VIP Thermo Single PN 6 / SDR 11

Type	Medium pipe, do1 x s1 [mm]	Jacket pipe do [mm]	Bending radius [m]	Weight [kg/m]	Volume medium pipe [l/m]	Coil length [m]	U-Value - [W/ m ² ·K]
40/140	40 x 3,7	140	0,35	1,67	0,83	200	0,098
50/140	50 x 4,6	140	0,40	1,93	1,31	200	0,115
63/140	63 x 5,8	140	0,50	2,35	2,07	200	0,138
75/140	75 x 6,8	140	0,60	2,73	2,96	200	0,163
90/175	90 x 8,2	175	0,70	4,00	4,25	100	0,166
110/175	110 x 10,0	175	0,90	5,08	6,36	100	0,209
125/200	125 x 11,4	200	1,30	6,65	8,20	120	0,215
140/200	140 x 12,7	200	1,70	8,52	10,31	100	0,253
160/250	160 x 14,6	250	2,10	10,14	13,43	80	0,247

Ecoflex VIP Thermo Twin PN 6 / SDR 11

Type	Medium pipe, do1 x s1 [mm]	Medium pipe, do2 x s2 [mm]	Jacket pipe do [mm]	Bending radius [m]	Weight [kg/m]	Volume medium pipe [l/m]	Coil length [m]	U-Value - [W/ m ² ·K]
2x 25/140	25 x 2,3	25 x 2,3	140	0,40	1,70	2x 0,33	200	0,122
2x 32/140	32 x 2,9	32 x 2,9	140	0,50	1,91	2x 0,54	200	0,145
2x 40/175	40 x 3,7	40 x 3,7	175	0,80	2,90	2x 0,83	200	0,153
2x 50/175	50 x 4,6	50 x 4,6	175	0,90	3,44	2x 1,31	200	0,185
2x 63/200	63 x 5,8	63 x 5,8	200	1,20	4,88	2x 2,07	100	0,212
2x 75/250	75 x 6,8	75 x 6,8	250	1,40	6,77	2x 2,96	100	0,222

Uponor Ecoflex Thermo and Varia

Uponor Ecoflex Thermo and Varia pipes, produced based on European Standard EN 15632 and EN 17414, are for heating and cooling applications. Varia pipes includes standard insulation thickness while Thermo has extended insulation. Single pipes are for projects with large flow requirements. Twin offers supply and return pipes in one jacket. The pipes have long coil lengths and high flexibility for good installation and energy efficiency.

Application

- Transport of heating and cooling water for buried installations.
- Operating temperature: 80 °C according to EN 15632.
- Maximum load temperature / pressure: 95 °C / 6 bar.
- Static verification for heavy traffic load of 60 tons.



Type	Description
Jacket pipe	Corrugated polyethylene (HDPE). Ring stiffness SN4 (4 kN/m ²) EN ISO 9969.
Insulation	Permanently elastic closed-cell cross-linked polyethylene (PE-X) foam. Thermal conductivity: $\lambda_{50} = 0,041$ W/mK.
Medium pipe	Cross-linked polyethylene (PE-Xa) pipe based on EN ISO 15875 with EVOH layer, natural colored, PN6 (SDR11)
Centre profile	Coloured blue/red polyethylene centre profile for Twin pipe.

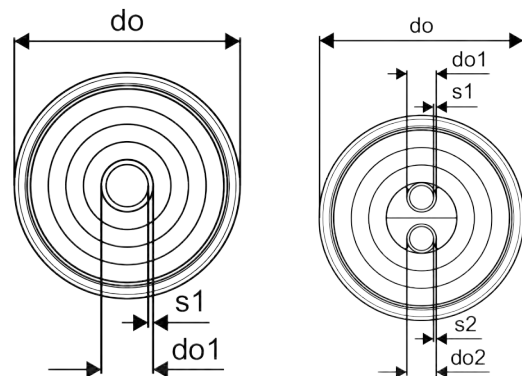

RP0000273

Ecoflex Thermo Single PN 6 / SDR 11

Type	Medium pipe, do1 x s1 [mm]	Jacket pipe do [mm]	Bending radius [m]	Weight [kg/m]	Volume medium pipe [l/m]	Coil length [m]	U-Value - [W / m ² · K]
25/140	25 x 2,3	140	0,25	1,18	0,33	200	0,141
32/140	32 x 2,9	140	0,30	1,31	0,54	200	0,162
40/175	40 x 3,7	175	0,35	2,03	0,83	200	0,162
50/175	50 x 4,6	175	0,45	2,26	1,31	200	0,188
63/175	63 x 5,8	175	0,55	2,56	2,07	200	0,226
75/200	75 x 6,8	200	0,80	3,74	2,96	100	0,233
90/200	90 x 8,2	200	1,10	4,20	4,25	100	0,279
110/200	110 x 10,0	200	1,20	5,24	6,36	100	0,356

Possible to equip with heating cable – on request, check availability in your market with a sales representative.

Ecoflex Varia Single PN 6 / SDR 11

Type	Medium pipe, do1 x s1 [mm]	Jacket pipe do [mm]	Bending radius [m]	Weight [kg/m]	Volume medium pipe [l/m]	Coil length [m]	U-Value - [W/ m·K]
25/90	25 x 2,3	90	0,25	1,02	0,33	200	0,172
32/90	32 x 2,9	90	0,30	1,12	0,54	200	0,207
40/140	40 x 3,7	140	0,35	1,47	0,83	200	0,189
50/140	50 x 4,6	140	0,40	1,67	1,31	200	0,226
63/140	63 x 5,8	140	0,50	1,97	2,07	200	0,284
75/175	75 x 6,8	175	0,60	2,72	2,96	200	0,267
90/175	90 x 8,2	175	0,70	3,14	4,25	100	0,329
110/175	110 x 10,0	175	0,90	4,14	6,36	100	0,443
125/200	125 x 11,4	200	1,30	5,80	8,20	120	0,433

Ecoflex Thermo Mini Single PN 6 / SDR 11

Type	Medium pipe, do1 x s1 [mm]	Jacket pipe do [mm]	Bending radius [m]	Weight [kg/m]	Volume medium pipe [l/m]	Coil length [m]	U-Value - [W/ m·K]
25/68	25 x 2,3	68	0,20	0,50	0,33	200	0,229
32/68	32 x 2,9	68	0,25	0,55	0,54	200	0,294

Ecoflex Thermo Twin 2x PN 6 / SDR 11

Type	Medium pipe, do1 x s1 [mm]	Medium pipe, do2 x s2 [mm]	Jacket pipe do [mm]	Bending radius [m]	Weight [kg/m]	Volume medium pipe [l/m]	Coil length [m]	U-Value - [W/ m·K]
2x 25/175	25 x 2,3	25 x 2,3	175	0,50	1,92	2x 0,33	200	0,194
2x 32/175	32 x 2,9	32 x 2,9	175	0,60	1,99	2x 0,54	200	0,230
2x 40/175	40 x 3,7	40 x 3,7	175	0,80	2,33	2x 0,83	200	0,286
2x 50/200	50 x 4,6	50 x 4,6	200	1,00	3,59	2x 1,31	100	0,303
2x 63/200	63 x 5,8	63 x 5,8	200	1,20	4,55	2x 2,07	100	0,426

Ecoflex Varia Twin 2x PN 6 / SDR 11

Type	Medium pipe, do1 x s1 [mm]	Medium pipe, do2 x s2 [mm]	Jacket pipe do [mm]	Bending radius [m]	Weight [kg/m]	Volume medium pipe [l/m]	Coil length [m]	U-Value - [W/ m·K]
2x 25/140	25 x 2,3	25 x 2,3	140	0,40	1,36	2x 0,33	200	0,236
2x 32/140	32 x 2,9	32 x 2,9	140	0,50	1,43	2x 0,54	200	0,293
2x 40/140	40 x 3,7	40 x 3,7	140	0,70	2,08	2x 0,83	200	0,398
2x 50/175	50 x 4,6	50 x 4,6	175	0,90	2,84	2x 1,31	200	0,371

Uponor Ecoflex Thermo Twin HP

Ecoflex Thermo Twin HP pipes are developed especially for heat pump application to manage all connections in only one pipe including heating flow and return pipes and also conduit pipes for power and sensor cable. It can also be used to connect an external sauna, a winter garden or a garage to name a few.

Application

- Ideal for heat pump connection, heating and cooling.
- Operating temperature: 80 °C according to EN 15632.
- Maximum load temperature / pressure: 95 °C / 6 bar.
- Static verification for heavy traffic load of 60 tons.
- Two cable conduits for power and data cables.

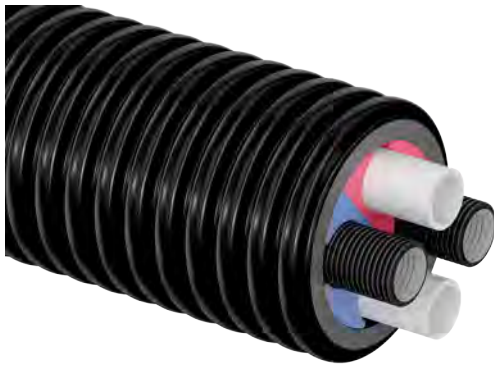

Type	Description
Jacket pipe	Corrugated polyethylene (HDPE). Ring stiffness SN4 (4 kN/m ²) EN ISO 9969.
Insulation	Permanently elastic closed-cell cross-linked polyethylene (PE-X) foam. Thermal conductivity: $\lambda_{50} = 0,041$ W/mK.
Medium pipe - heating	Cross-linked polyethylene (PE-Xa) pipe based on EN ISO 15875 with EVOH layer, natural colored, PN6 (SDR11)
Conduit pipe	Black corrugated conduit pipes for electrical power and data cables.
Centre profile	Coloured blue/red polyethylene centre profile for Twin pipe.

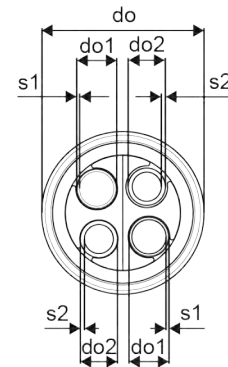

RP000231

Ecoflex Thermo Twin HP 2x PN 6 / SDR 11 + 2 conduits

Type	Medium pipe, do1 x s1 [mm]	Medium pipe, do2 x s2 [mm]	Jacket pipe do [mm]	Bending radius [m]	Weight [kg/m]	Volume medium pipe [l/m]	Coil length [m]	U-Value - [W/ m ² ·K]
2x 32/140	2x 32 x 2,9	2x 32 x 3,5	140	0,50	1,70	2x 0,54	200	0,347
2x 40/175	2x 40 x 3,7	2x 32 x 3,5	175	0,80	2,60	2x 0,83	200	0,376

2.4 Warm tap water

Uponor Ecoflex VIP Aqua

Uponor Ecoflex VIP Aqua pipes are a reliable choice for hygienic and energy-efficient distribution of warm tap water in buried installations. VIP Aqua pipes come in two versions: single pipe for large flow capacity or when one supply line is sufficient; twin pipe with supply and circulating pipe in the same jacket. The pipes have extremely good insulation performance and flexibility. Available in long coils or in requested length.

Application

- Transport of warm tap water for buried installations.
- Operating temperature: 70 °C according to EN ISO 15875.
- Maximum load temperature / pressure: 95 °C / 10 bar.
- Static verification for heavy traffic load of 60 tons.

Type	Description
Jacket pipe	Corrugated polyethylene (HDPE). Ring stiffness SN4 (4 kN/m ²) EN ISO 9969.
PE-X insulation	Permanently elastic closed-cell cross-linked polyethylene (PE-X) foam. Thermal conductivity: $\lambda_{50} = 0,041$ W/mK.
VIP insulation	Vacuum insulated panel. Thermal conductivity: $\lambda_{50} = 0,004$ W/mK.
Medium pipe	Cross-linked polyethylene (PE-Xa) pipe based on EN ISO 15875, natural coloured, PN 10 (SDR 7,4)
Centre profile	Coloured blue/red polyethylene centre profile for Twin pipe.

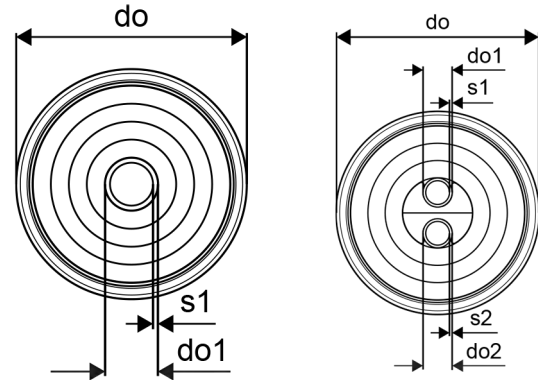
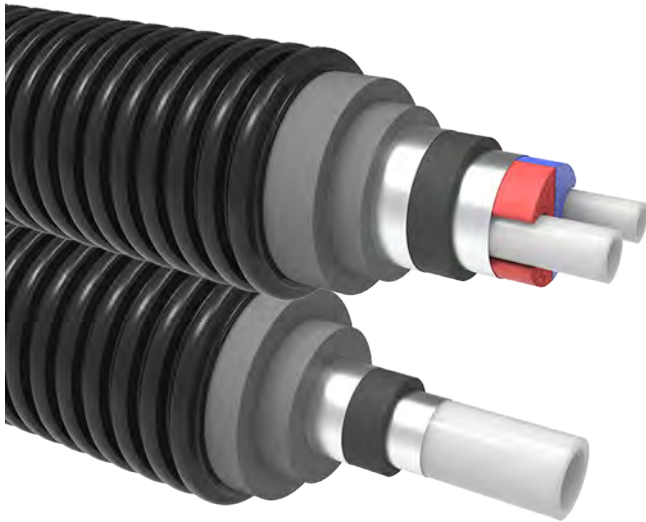

RP0000274

Ecoflex VIP Aqua Single PN 10 / SDR 7,4

Type	Medium pipe, do1 x s1 [mm]	Jacket pipe do [mm]	Bending radius [m]	Weight [kg/m]	Volume medium pipe [l/m]	Coil length [m]	U-Value - [W/ m ² ·K]
40/140	40 x 5,5	140	0,40	1,84	0,66	200	0,098
50/140	50 x 6,9	140	0,45	2,19	1,03	200	0,115
63/140	63 x 8,6	140	0,55	2,76	1,65	200	0,137
75/140	75 x 10,3	140	0,70	3,33	2,32	100	0,161
90/175	90 x 12,3	175	0,80	4,88	3,36	100	0,165
110/175	110 x 15,1	175	1,00	6,33	5,00	100	0,207

Ecoflex VIP Aqua Twin 2x PN 10 / SDR 7,4

Type	Medium pipe, do1 x s1 [mm]	Medium pipe, do2 x s2 [mm]	Jacket pipe do [mm]	Bending radius [m]	Weight [kg/m]	Volume medium pipe [l/m]	Coil length [m]	U-Value - [W/ m ² ·K]
25-20/140	25 x 3,5	20 x 2,8	140	0,45	1,74	0,25 + 0,16	200	0,118
32-20/140	32 x 4,4	20 x 2,8	140	0,55	1,88	0,42 + 0,16	200	0,125
40-25/140	40 x 5,5	25 x 3,5	140	0,70	2,18	0,66 + 0,25	200	0,148
50-32/175	50 x 6,9	32 x 4,4	175	0,80	3,36	1,03 + 0,42	200	0,158
63-40/175	63 x 8,6	40 x 5,5	200	0,90	4,83	1,65 + 0,66	100	0,171

Uponor Ecoflex Aqua

Uponor Ecoflex Aqua is the proven choice with ease of installation and good quality insulation. Unbeatable for fast, reliable and therefore very economical installation in the hot water service system. The twin version offers a solution with an integrated circulation pipe, warm water and circulation combined in one pipe. The two-coloured centring profile simplifies correct connection of the medium pipes.

The classification of the PE-Xa medium pipes for the Aqua pipe system are described in EN ISO 15875.

Application

- Transport of warm tap water for buried installations.
- Operating temperature up to 70 °C based on EN ISO 15875.
- Maximum load temperature / pressure: 95 °C / 10 bar.
- Static verification for heavy traffic load of 60 tons.

Type	Description
Jacket pipe	Corrugated polyethylene (HDPE). Ring stiffness SN4 (4 kN/m ²) EN ISO 9969.
Insulation	Permanently elastic closed-cell cross-linked polyethylene (PE-X) foam. Thermal conductivity: $\lambda_{50} = 0,041$ W/mK.
Medium pipe	Cross-linked polyethylene (PE-Xa) pipe based on EN ISO 15875, natural coloured, PN 10 (SDR 7,4)
Centre profile	Coloured blue/red polyethylene centre profile for Twin pipe.

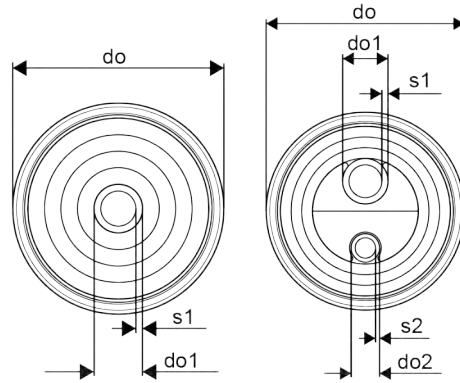
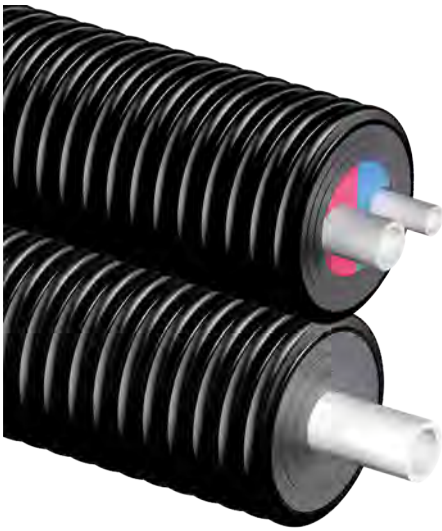

FR000275

Ecoflex Aqua Single PN 10 / SDR 7,4

Type	Medium pipe, do1 x s1 [mm]	Jacket pipe do [mm]	Bending radius [m]	Weight [kg/m]	Volume medium pipe [l/m]	Coil length [m]	U-Value - [W/ m·K]
25/140	25 x 3,5	140	0,35	1,24	0,25	200	0,140
28/140*	28 x 4,0	140	0,35	1,30	0,31	200	0,149
32/140	32 x 4,4	140	0,40	1,42	0,42	200	0,161
40/175	40 x 5,5	175	0,45	2,40	0,66	200	0,160
50/175	50 x 6,9	175	0,55	2,70	1,03	200	0,186
63/175	63 x 8,6	175	0,65	3,20	1,65	200	0,224

*Available only in Finland

Ecoflex Aqua Twin 2x PN 10 / SDR 7,4

Type	Medium pipe, do1 x s1 [mm]	Medium pipe, do2 x s2 [mm]	Jacket pipe do [mm]	Bending radius [m]	Weight [kg/m]	Volume medium pipe [l/m]	Coil length [m]	U-Value - [W/ m·K]
25-20/140	25 x 3,5	20 x 2,8	140	0,65	1,75	0,25 + 0,16	200	0,222
25-25/175	25 x 3,5	25 x 3,5	175	0,65	2,05	0,25 + 0,25	200	0,193
28-18/140*	28 x 4,0	18 x 2,5	140	0,65	1,40	0,31 + 0,13	200	0,228
28-22/140*	28 x 4,0	22 x 3,0	140	0,65	1,50	0,31 + 0,20	200	0,237
32-18/175*	32 x 4,4	18 x 2,5	175	0,70	2,30	0,42 + 0,13	200	0,198
32-20/175	32 x 4,4	20 x 2,8	175	0,70	2,40	0,42 + 0,16	200	0,198
32-22/175*	32 x 4,4	22 x 3,0	175	0,70	2,40	0,42 + 0,20	200	0,211
32-25/175	32 x 4,4	25 x 3,5	175	0,70	2,20	0,42 + 0,25	200	0,217
32-28/175*	32 x 4,4	28 x 4,0	175	0,70	2,50	0,42 + 0,31	200	0,222
40-25/175	40 x 5,5	25 x 3,5	175	0,90	2,45	0,66 + 0,25	200	0,234
40-28/175*	40 x 5,5	28 x 4,0	175	0,90	2,70	0,66 + 0,31	200	0,240
40-32/175	40 x 5,5	32 x 4,4	175	0,90	2,80	0,66 + 0,42	200	0,265
50-25/175	50 x 6,9	25 x 3,5	175	1,00	2,73	1,03 + 0,25	200	0,282
50-32/175	50 x 6,9	32 x 4,4	175	1,00	3,10	1,03 + 0,42	200	0,296
50-40/200	50 x 6,9	40 x 5,5	200	1,00	3,50	1,03 + 0,66	100	0,279
50-50/200	50 x 6,9	50 x 6,9	200	1,00	3,60	1,03 + 1,03	100	0,301

*Available only in Finland

2.5 Heating and warm tap water

Uponor Ecoflex Quattro

Uponor Ecoflex Quattro is an all-in-one pipe solution for all requirements: extensive supply networks or a single connection to one building. It provides heating, warm tap water supply and circulation pipes in the same jacket: two pipes are intended for warm tap water and the other two for heating.

Application

- Transport of heating and warm tap water for buried installations.
- Operating temperature up to 80 °C based on EN 15632 for heating and up to 70 °C based on EN ISO 15875 for warm tap water.
- Maximum load temperature / pressure: 95 °C / 6 bar for heating and 10 bar for warm tap water.
- Static verification for heavy traffic load of 60 tons.

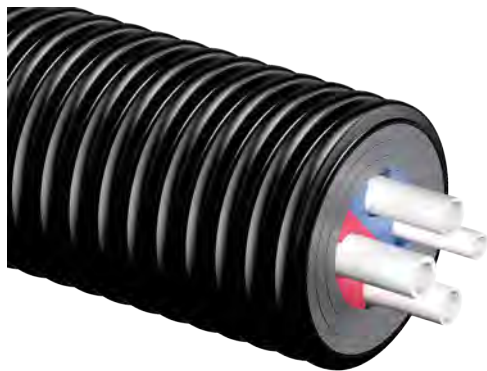

Type	Description
Jacket pipe	Corrugated polyethylene (HDPE). Ring stiffness SN4 (4 kN/m ²) EN ISO 9969.
Insulation	Permanently elastic closed-cell cross-linked polyethylene (PE-X) foam. Thermal conductivity: $\lambda_{50} = 0,041$ W/mK.
Medium pipe - warm water	Cross-linked polyethylene (PE-Xa) pipe based on EN ISO 15875, natural coloured, PN 10 (SDR 7,4)
Medium pipe - heating	Cross-linked polyethylene (PE-Xa) pipe based on EN ISO 15875 with EVOH layer, natural colored, PN6 (SDR11)
Centre profile	Coloured blue/red polyethylene centre profile.

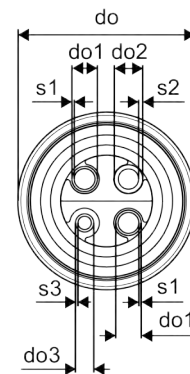

RF0000236

Ecoflex Quattro 2x PN 6 / SDR 11 + 2x PN 10 / SDR 7,4

Type	Medium pipe, do1 x s1 [mm]	Medium pipe, do2 x s2 [mm]	Medium pipe, do3 x s3 [mm]	Jacket pipe do [mm]	Bending radius [m]	Weight [kg/m]	Coil length [m]	U-Value - [W/ m·K]
2x 25-28-18/175*	2 x 25 x 2,3	28 x 4,0	18 x 2,5	175	0,8	2,40	200	0,270
2x 25-25-20/175	2 x 25 x 2,3	25 x 3,5	20 x 2,8	175	0,8	2,30	200	0,266
2x 25-25-25/175	2 x 25 x 2,3	25 x 3,5	25 x 3,5	175	0,8	2,41	200	0,273
2x 32-25-20/175	2 x 32 x 2,9	25 x 3,5	20 x 2,8	175	0,8	2,50	200	0,290
2x 32-25-25/175	2 x 32 x 2,9	25 x 3,5	25 x 3,5	175	0,8	2,64	200	0,296
2x 32-28-18/175*	2 x 32 x 2,9	28 x 4,0	18 x 2,5	175	0,8	2,60	200	0,294
2x 32-32-18/175*	2 x 32 x 2,9	32 x 4,4	18 x 2,5	175	0,8	2,80	200	0,303
2x 32-32-20/175	2 x 32 x 2,9	32 x 4,4	20 x 2,8	175	0,8	2,90	200	0,305
2x 32-32-25/175	2 x 32 x 2,9	32 x 4,4	25 x 3,5	175	0,8	2,78	200	0,311
2x 32-32-32/175	2 x 32 x 2,9	32 x 4,4	32 x 4,4	175	0,8	2,90	200	0,322
2x 40-32-18/200*	2x 40 x 3,7	32 x 4,4	18 x 2,5	200	0,8	3,40	100	0,307
2x 40-32-20/200	2x 40 x 3,7	32 x 4,4	20 x 2,8	200	1,0	3,50	100	0,308
2x 40-40-25/200	2x 40 x 3,7	40 x 5,5	25 x 3,5	200	1,0	3,60	100	0,328
2x 40-40-28/200*	2x 40 x 3,7	40 x 5,5	28 x 4,0	200	1,0	3,70	100	0,331

*Available only in Finland

Uponor Ecoflex Quattro Midi

Uponor Ecoflex Quattro Midi is an all-in-one pipe solution mainly for a single connection to one building where high flexibility is highly requested. It provides heating, warm tap water supply and circulation pipes in the same jacket: two pipes are intended for warm tap water and the other two for heating.

Application

- Transport of heating and warm tap water for buried installations.
- Operating temperature up to 80 °C based on EN 15632 for heating and up to 70 °C based on EN ISO 15875 for warm tap water.
- Maximum load temperature / pressure: 95 °C / 6 bar for heating and 10 bar for warm tap water.
- Static verification for heavy traffic load of 60 tons.



Type	Description
Jacket pipe	Corrugated polyethylene (HDPE). Ring stiffness SN4 (4 kN/m ²) EN ISO 9969.
Insulation	Permanently elastic closed-cell cross-linked polyethylene (PE-X) foam. Thermal conductivity: $\lambda_{50} = 0,041$ W/mK.
Medium pipe - warm water	Cross-linked polyethylene (PE-Xa) pipe based on EN ISO 15875, natural coloured, PN 10 (SDR 7,4)
Medium pipe - heating	Cross-linked polyethylene (PE-Xa) pipe based on EN ISO 15875 with EVOH layer, natural colored, PN6 (SDR11)

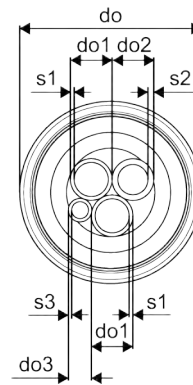

RP000277

Ecoflex Quattro Midi 2x PN 6 / SDR 11 + 2x PN 10 / SDR 7,4

Type	Medium pipe, do1 x s1 [mm]	Medium pipe, do2 x s2 [mm]	Medium pipe, do3 x s3 [mm]	Jacket pipe do [mm]	Bending radius [m]	Weight [kg/m]	Coil length [m]	U-Value - [W/ m·K]
2x 25-25-20/140	2x 25 x 2,3	25 x 3,5	20 x 2,8	140	0,65	1,84	200	0,282
2x 32-25-20/140	2x 32 x 2,9	25 x 3,5	20 x 2,8	140	0,70	2,00	200	0,303
2x 40-32-25/175	2x 40 x 3,7	32 x 4,4	25 x 3,5	175	0,80	3,20	200	0,307

2.6 Cold water and cooling

Uponor Ecoflex Supra

Ecoflex Supra is designed for cold potable water applications and chilled water distribution for cooling systems where no frost protection required. Supra is optimized for use in applications at temperatures between -10 °C and +20 °C.

Application

- Transport of cold potable or cooling water for buried installations.
- Operating temperature: +20 °C.
- Maximum pressure: 16 bar at 20 °C.
- Static verification for heavy traffic load of 60 tons.

Type	Description
Jacket pipe	Corrugated polyethylene (HDPE). Ring stiffness SN4 (4 kN/m ²) EN ISO 9969.
Insulation	Permanently elastic closed-cell cross-linked polyethylene (PE-X) foam. Thermal conductivity: $\lambda_{10} = 0,037$ W/mK.
Medium pipe	Polyethylene PE100 RC, black with blue stripes, PN 16 (SDR 11).

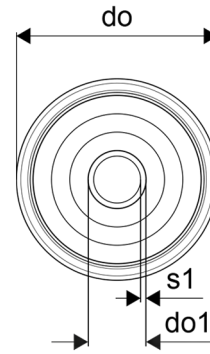

RP0000242

Ecoflex Supra PN 16 / SDR 11 - without cable

Type	Medium pipe, do1 x s1 [mm]	Jacket pipe do [mm]	Bending radius [m]	Weight [kg/m]	Volume medium pipe [l/m]	Coil length [m]	U-Value - [W/ m·K]
25/68	25 x 2,3	68	0,30	0,52	0,33	200	0,230
32/68	32 x 2,9	68	0,40	0,62	0,54	200	0,305
40/140	40 x 3,7	140	0,50	1,47	0,83	200	0,184
50/140	50 x 4,6	140	0,60	1,67	1,31	200	0,224
63/140	63 x 5,8	140	0,70	1,97	2,07	200	0,288
75/175	75 x 6,8	175	0,90	2,72	2,96	100	0,267
90/175	90 x 8,2	175	1,00	3,14	4,25	100	0,338
110/200	110 x 10,0	200	1,20	5,24	6,36	100	0,368

Uponor Ecoflex Supra PLUS

Ecoflex Supra PLUS is designed for cold potable water supply lines with one or two self regulating frost protection cable, which is controlled by a specially designed control unit with sensor. The system enables transportation of potable water even at the lowest ambient temperatures. Electricity feed from one supply point max. 150 m.

Application

- Transport of cold potable water or pressure drainage in locations where there is a risk of freezing for buried installations.
- Operating temperature: +20 °C.
- Maximum pressure: 16 bar at 20 °C.
- Static verification for heavy traffic load of 60 tons.

Type	Description
Jacket pipe	Corrugated polyethylene (HDPE). Ring stiffness SN4 (4 kN/m ²) EN ISO 9969.
Cable	Self-regulating frost protection cable, nominal power output 10 W/m at 5 °C. Electricity feed from one supply point max. 150 m.
Conduit	PE tube to insert a sensor for temperature measurement.
Insulation	Permanently elastic closed-cell cross-linked polyethylene (PE-X) foam. Thermal conductivity: $\lambda_{10} = 0,037$ W/mK.
Medium pipe	Polyethylene PE100 RC, black with blue stripes, PN 16 (SDR 11).

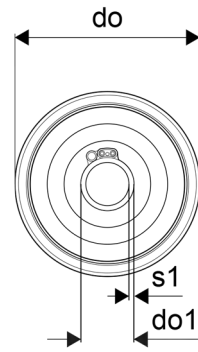

RP0000243

Ecoflex Supra PLUS PN 16 / SDR 11 - with self regulation frost protection cable

Type	Medium pipe, do1 x s1 [mm]	Jacket pipe do [mm]	Bending radius [m]	Weight [kg/m]	Volume medium pipe [l/m]	Coil length [m]	U-Value - [W/ m·K]
25/68	25 x 2,3	68	0,30	0,58	0,33	150	0,230
32/68	32 x 2,9	68	0,40	0,67	0,54	150	0,305
32/140	32 x 2,9	140	0,50	1,20	0,54	150	0,157
40/90	40 x 3,7	90	0,50	1,08	0,83	150	0,254
40/140	40 x 3,7	140	0,50	1,50	0,83	150	0,184
50/90	50 x 4,6	90	0,50	1,26	1,31	150	0,336
50/140	50 x 4,6	140	0,60	1,70	1,31	150	0,224
63/140	63 x 5,8	140	0,70	2,10	2,07	150	0,288
75/175	75 x 6,8	175	0,90	2,90	2,96	150	0,267
90/200	90 x 8,2	200	1,10	4,40	4,25	100	0,279
110/200	110 x 10,0	200	1,20	5,10	6,36	100	0,368

Self-regulating cable

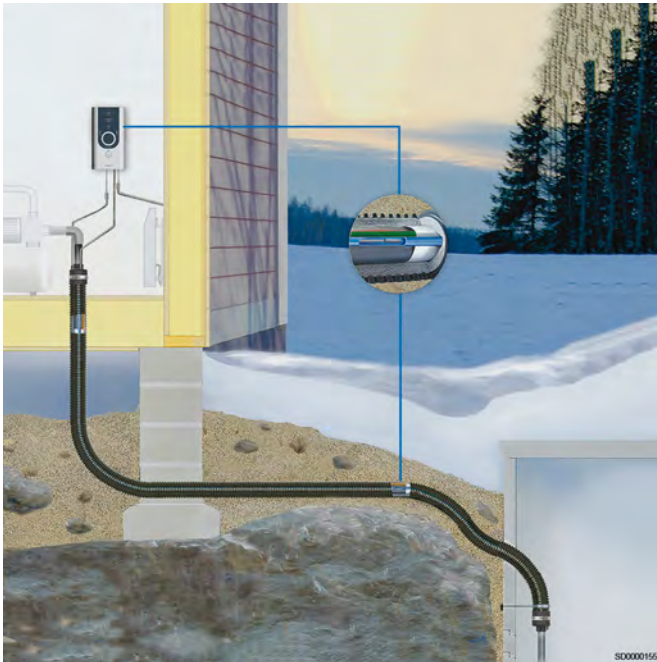

The frost protection cable of the Supra PLUS pipe is self-regulating and thus cannot overheat.

The cable does not require maintenance but must be switched off and protected from mechanical damage during any repairs to the pipeline. After repairs are completed, the insulation resistance must be measured and entered in the test log.

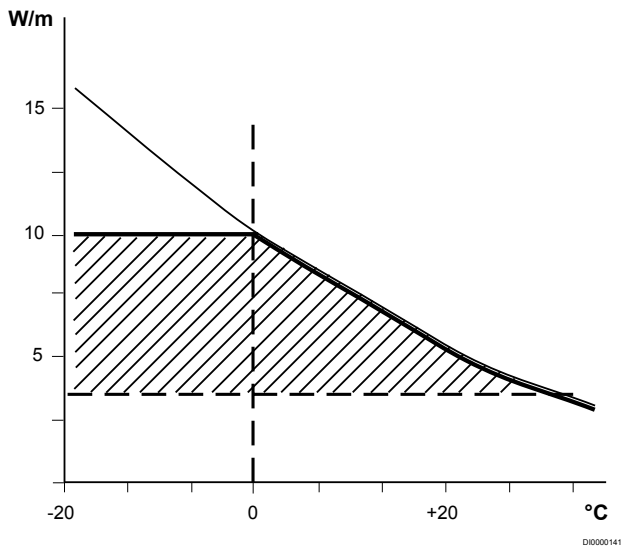

DI0000141

The frost protection cable supplies full power in ice, cold water or in a frozen pipeline. The ruled area in the image shows the input power W/m depending on the outdoor temperature when the frost protection cable is on continuously.

The use of the frost protection cable is controlled using a control unit with timer and thermostat functions. Power supply to the frost protection cable is switched off from the operating switch when there is no risk of freezing. If the pipeline is in occasional use, the cable can also be used to defrost a frozen pipeline.

Cable functionality

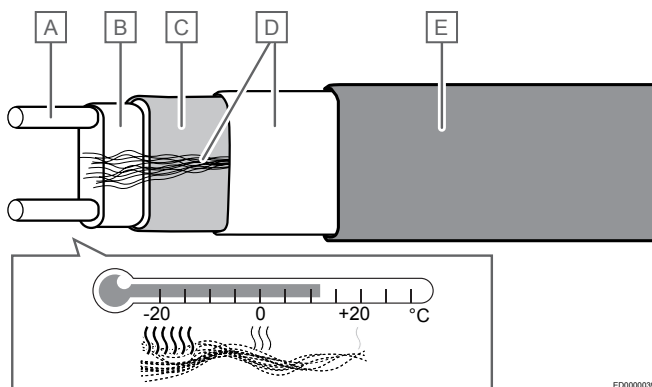

ED0000039

Item	Description
A	Conductors, 1,2 mm ² copper wires
B	Self-regulation resistor material
C	Electrical insulation (polyolefin)
D	Aluminium foil and drain wires
E	Outer jacket

The self-regulating frost protection cable has been designed specifically to prevent the pipes from freezing. This feature, combined with good insulation, guarantees a frost free and safe solution. The heating part of the self-regulating frost protection cable is a conductive polymer extruded between two copper wires (phase and zero).

In cold parts, a high current travels from one wire to another creating heat in the core material (B). In the warmer parts of the cable, the resistance of the material grows, the current flow slows down and heat output is reduced. The heat production of the cable remains balanced and the heating capacity is regulated according to ambient conditions separately in each part of the pipe.

In low temperatures, Supra PLUS provides adequate power to prevent freezing. As the temperature increases, the power is reduced and less heat is generated. The self-regulating functionality of Supra PLUS pipes ensures safe operating conditions.

Uponor Ecoflex Supra PLUS control unit



PH0000164

The Uponor Ecoflex Supra PLUS control unit is an electronic regulator designed for controlling the self-regulating frost protection cable of the Supra PLUS pipe. The control unit has two different functions, either a function with a temperature sensor or a fixed timer function.

Timer function



RP0000244

The timer is used to regulate the power supply to the cable. It is an easy way to reduce power consumption and to prevent the harmful heating of the water in the pipeline. The timer regulation area corresponds to a 30 minute switching cycle.

On the maximum setting at 100 %, the frost protection cable is on during the entire switching cycle. On the minimum setting at 10 %, the frost protection cable is on for 3 minutes and off for 27 minutes. The switching cycle must be selected on a case by case basis according to the prevailing conditions. When using a timer to defrost a frozen pipe, the dial is set at 100 %.

Thermostat function



RP0000245

The thermostat function is used for controlling the cable when a certain pre-set temperature should not be exceeded. The temperature range controlled using the thermostat is 0 – 10 °C and control takes place with the adjuster wheel on the thermostat unit.

The thermostat sensor is installed in the pipe element inside the feed pipe. The sensor installation location should be the location most susceptible to freezing. If the sensor cannot be installed in the location most susceptible to freezing, this should be taken into account by setting the thermostat maintenance temperature higher.

Connections

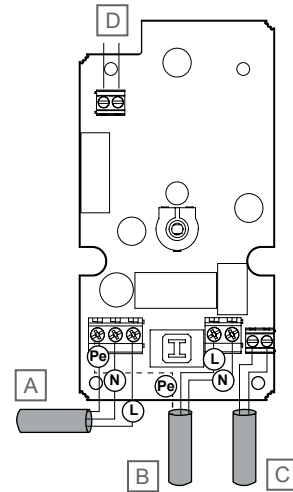

SD0000154

Item	Description
A	Supply cable 230 V AC
B	Heating cable
C	External temperature sensor
D	Remote control

Remove the adjusting wheel, unscrew the fixing screw and remove the cover of the thermostat. Connect the 230 V AC supply cable (A), the Supra PLUS heating cable (B), the sensor cable (C), and the protective earth to the incoming supply cable and the protective flex of the heating cable. The thickness of the connecting wires is determined according to the size of the main fuse. 10 A -> 3 x 1,5 mm² and 16 A -> 3 x 2,5 mm².

The installations should be carried out in accordance with the fixed installation method. The control unit also has a potential-free switch (230 V AC or SELV voltage, max load 5 A) for remote control, which is activated in a fault situation. If necessary, punch a hole in the top part of the device for the remote monitoring cable, which must be laid according to the requirements of the control voltage.

Uponor Ecoflex Mantle



RP0000095

Ecoflex Mantle is an insulated jacket for water pipe inlet. It protects the parts of a water pipe most susceptible to freezing, generally near the building foundation or inside a ventilated floor system. The jacket can be used for new buildings and renovation.

Mantle is equipped with a frost protection cable that prevents the water pipe from freezing. It is an easy and effective way to protect the water pipes around the building from damage caused by freezing and, at the same time, it functions as a jacket pipe for the water pipe, enabling the replacing of the water pipe in case damage occurs.

The frost protection cable brings the required heat into the jacket pipe and the insulation layer helps retain the heat in the jacket pipe. Water remains unfrozen even in extremely cold temperatures in all locations susceptible to freezing.

The frost protection cable connections in the Mantle jacket pipe are ready for use. Connection to the electrical network is with a plug and the power outlet used must be equipped with a fault current protection. In the connection end, there is approximately 1 m of extra frost protection cable, which can be used to protect the medium pipe from freezing during winter construction. The plug is connected to the socket when there is a risk of water pipe freezing. The maximum capacity of the cable is 10 W/m, enough to keep a water pipe unfrozen in a temperature of -25 °C.

Uponor Ecoflex Supra Standard

Supra Standard is a versatile insulated water pipe. The regulator-controlled constant resistant frost protection cable keeps the pipe from freezing. The regulator also maintains the pipe's temperature at the required level. The system can be connected to either 230 V or 400 V voltage. Supra Standard is an economical solution for the installation of long non-freezing water and waste water pipes as well as various industrial fluid pipes in conditions susceptible to freezing. Its power consumption is small, because the surface temperature of the cable is extremely carefully monitored.

The Supra Standard pipe is manufactured with two different constant resistant cables with a constant resistance throughout the length of the cable. The yellow cable 2 x 0,48 Ω/m is intended for pipe lengths 70 - 300 m and the white cable 2 x 0,05 Ω/m for lengths of 150 - 700 m. Longer pipelines require several power supply points.

Supra Standard is supplied on coil and ready for installation. The system contains complete sets for joining, branching and extending a pipe (medium pipe couplings are not contained in the sets).

Type	Description
Jacket pipe	Corrugated polyethylene (HDPE). Ring stiffness SN4 (4 kN/m ²) EN ISO 9969.
Cable	Self-regulating frost protection cable, nominal output of 10 W/m and supply voltage of 230 V.
Insulation	Permanently elastic closed-cell cross-linked polyethylene (PE-X) foam. Thermal conductivity: λ ₁₀ – 0,037 W/mK.

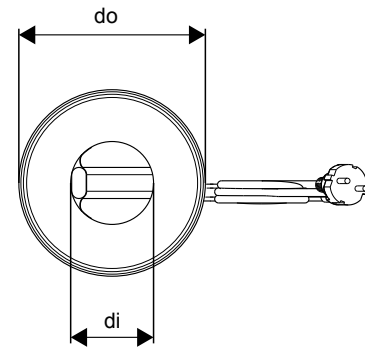

ED0000053

Jacket pipe do [mm]	Inner diameter di [mm]	Weight [kg/m]	Max. length on delivery [m]
90	25 – 40	5,4	5

Type	Description
Jacket pipe	Corrugated polyethylene (HDPE). Ring stiffness SN4 (4 kN/m ²) EN ISO 9969.
Cable	Constant resistant frost protection cables: The yellow cable 2 x 0,48 Ω/m for pipe lengths 50 - 300 m and the white cable 2 x 0,05 Ω/m for lengths of 150 - 700 m.
Insulation	Permanently elastic closed-cell cross-linked polyethylene (PE-X) foam. Thermal conductivity: λ ₁₀ – 0,037 W/mK.
Medium pipe	Polyethylene PE100 RC, black with blue stripes, PN 16 (SDR 11).

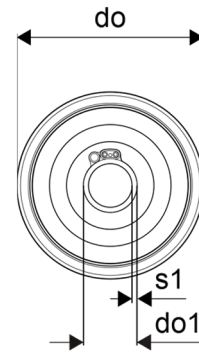
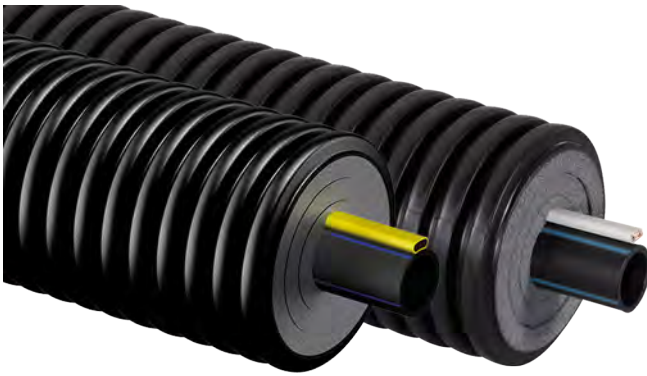

RP00002/75

Ecoflex Supra Standard PN 16 / SDR 11 - with white or yellow cable

Type	Medium pipe, do1 x s1 [mm]	Jacket pipe do [mm]	Bending radius [m]	Weight [kg/m]	Volume medium pipe [l/m]	Coil length [m]	U-Value - [W/ m·K]
32/68	32 x 2,9	68	0,40	0,67	0,54	150	0,305
40/90	40 x 3,7	90	0,50	1,08	0,83	150	0,254
40/140	40 x 3,7	140	0,50	1,50	0,83	150	0,184
50/90	50 x 4,6	90	0,50	1,26	1,31	150	0,336
50/140	50 x 4,6	140	0,60	1,70	1,31	150	0,224
63/140	63 x 5,8	140	0,70	2,10	2,07	150	0,288
75/175	75 x 6,8	175	0,90	2,90	2,96	150	0,267
90/200	90 x 8,2	200	1,10	4,40	4,25	100	0,279
110/200	110 x 10,0	200	1,20	5,10	6,36	100	0,368

Supra standard constant resistant cable

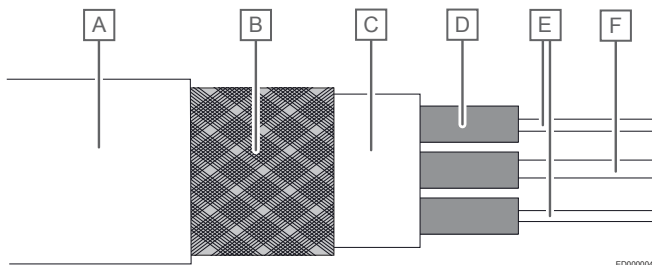

ED0000046

White cable

Item	Description
A	Outer jacket 0,6 mm PVC
B	Copper braid
C	Mantle 0,4 mm
D	PVC Insulation 0,4 mm
E	Resistor wires 0,05 Ω/m
F	Copper wire 2,5 mm ²

White cable - 230 V/400 V, 2 x 0,05 Ω/m (min. 150 m – max. 700 m)

Yellow cable

Item	Description
A	Outer jacket 0,6 mm PVC
B	Copper braid
C	Mantle 0,4 mm
D	PVC Insulation 0,4 mm
E	Resistor wires 0,48 Ω/m
F	Copper wire 1,5 mm ²

Yellow cable - 230 V/400 V, 2 x 0,48 Ω/m (min. 50 m – max. 300 m)

Cable function

The heating power of the constant resistant cable on Supra Standard pipe is controlled using a regulator and an NTC sensor. The temperature sensor attached on the cable surface communicates any heating needs with the regulator and ensures that the cable cannot overheat even in adverse temperature conditions. This retains the pressure proof qualities of the pipe and the plastic material is not damaged.

The regulator switches the power on and off so that the cable surface temperature remains at the set standard value (0 – 30 °C). Thanks to good insulation properties, the duration of effective heating periods is approximately 40 % of the total time, providing considerable savings in the consumption of power in comparison with continuous heating. The constant resistant cables of Supra Standard allow supply of electricity from one point to a 700 meter long line.

Uponor Ecoflex Supra Standard thermostat ETN4



HP000284

Supra Standard thermostat ETN4 is used to control the constant resistance heat trace cable of the Supra Standard pipes. It will be supplied in a splash water proof switch box and with a temperature sensor connected with a 10m cord. The large backlit display provides a clear view of status, while the three navigation buttons allow easy menu operation. The thermostat allows a required temperature to be set within the range -19,5 to +70 °C. For Supra Standard pipes the recommended temperature range is 0...+20°C.

The supply cable, the constant resistance heat trace cable and the sensor cable to be installed in to the pipe element are all connected to ETN4 thermostat. Please see the wiring diagram for more detailed information about the connections.

3 Uponor Ecoflex components

Note
Detailed information about the range of components, dimensions etc is available in the price list.

3.1 Uponor Wipex fittings



The Uponor Wipex fittings are designed for connecting PE-Xa pipes for hot and cold water service in domestic and district heating installations. Uponor Wipex fittings have a robust and simple design, with high gripping strength and sealing performance unaffected by temperature fluctuations. The fittings are also easy and efficient to install, no special tools are needed. As the Uponor Wipex fittings use O-ring sealing, the use of teflon or hemp for additional sealing is not required.

The Uponor Wipex fittings are made of dezincification resistant DR brass, with good corrosion resistance and durability.

Uponor Wipex jointing technology

Note
When connecting the Uponor Wipex system to third-party components, the terminating Uponor Wipex fitting must have an inside thread (e.g. an elbow).

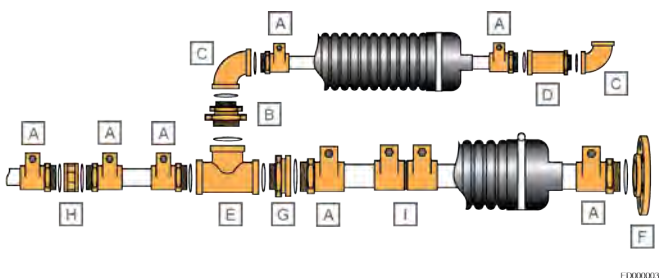

Item	Description
A	Coupling
B	Swivel union
C	Elbow
D	Fix point bushing
E	Tee
F	Flange
G	Reducer
H	Sleeve
I	Jointing equal

Dimensions

Uponor Wipex fittings are available for pipe dimensions 25-110 mm, in two series marked PN 6 and PN 10.

3.2 Uponor Ecoflex fittings



The Uponor Ecoflex fittings are designed for connecting PE-Xa pipes in district heating installations. Uponor Ecoflex fittings are available for pipe dimensions 125-160 mm in pressure class PN 6.

3.3 Adapters for Uponor Wipex and Ecoflex fittings



Uponor Ecoflex system includes a range of adapters, which allow connection from Uponor Wipex and Ecoflex fittings to other systems. These include:

- Uponor Wipex S-Press adapter (for connecting to the Uponor multi-layer composite pipe system)
- Uponor Wipex RS adapter (for connecting to Uponor Riser System)
- Uponor Ecoflex weldable adapter (for connecting steel district heating pipes)

3.4 Uponor Q&E fittings



PH0000152

The Uponor Q&E fitting is based on a method where a Uponor PE-Xa pipe is gradually expanded with a Q&E (PEX) ring fitted on the outside, and then allowing it to shrink back onto a fitting nipple. The technique can be used as the Uponor PEX material is capable of shrinking back to almost its original size, even after a very large amount of expansion.

This type of connection is non-removable. A further benefit is that the inner diameter reduction caused by the fitting is minimal.

Testing and approvals

Uponor Q&E fittings got their first certifications already in 1995. Since then they have been tested in performance and certified by several independent official accredited laboratories, such as ATG (Belgium), DVGW (Germany), KIWA (the Netherlands), MPA (Germany), SP (Sweden), TGM (Austria), QAS (Australia) as well as in Uponor's own laboratories.

Range of fittings



PH0000150

The system is based upon the unique properties of Uponor PE-Xa pipes and the revolutionary Q&E fitting.

Uponor Q&E fittings are available in brass, dezincification resistant brass (DR) and a durable, proven plastic called polyphenylsulphone (PPSU). Only an expander tool is needed for connecting the pipe to the fitting.

Uponor Q&E fittings are available for pipe dimensions up to 75 mm in pressure class PN 6 and PN 10.

3.5 Plastic fittings for Ecoflex Supra pipes



Note

The plastic fittings described in this section are third-party products and are not provided by Uponor.



PH0000149

Item	Description
A	Compression fitting
B	Electro-fusion fitting

Plastic compression fittings have been tried and proven over many years as the perfect connection for PE-HD medium pipes. These fittings provide both a safe connection and fast installation of Supra pipe systems. Supra pipes can also be connected by commonly available electro-fusion fittings, which are approved for PE 100, SDR 11 pipes.

3.6 Uponor Ecoflex rubber end caps



Note

Uponor Ecoflex rubber end caps have been tested for watertightness up to 0,3 bar.

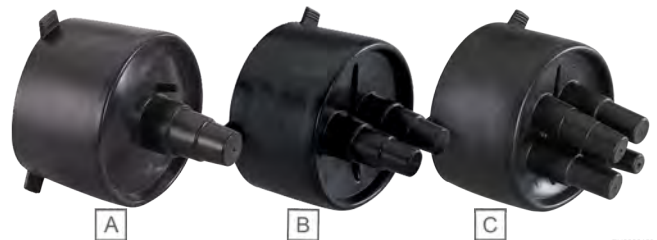

PH0000153

Item	Description
A	Single
B	Twin
C	Quattro

Uponor Ecoflex rubber end caps protect the insulation at pipe ends and provide partitions between components. It is important to provide this protection against moisture and damage, so that the whole system can fulfill its purpose optimally over many years.

A sealing ring is also supplied to prevent the entry of water. The end caps can be assembled by pulling them over the ends of the pipes, after which they are fully secured with a clamping ring.

3.7 Uponor Ecoflex insulation sets

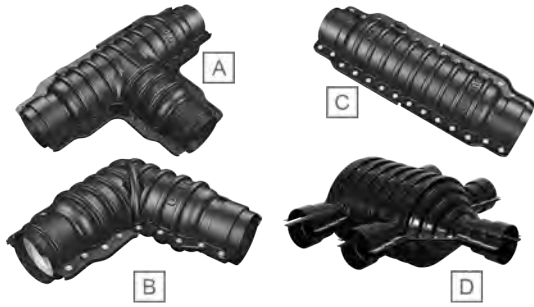

FP0000154

Item	Description
A	Uponor Ecoflex T-insulation set
B	Uponor Ecoflex elbow insulation set
C	Uponor Ecoflex straight insulation set
D	Uponor Ecoflex H-insulation set

The selection of insulation sets includes different T-sets, one elbow set and one straight set. Due to its special design and high quality ABS material the insulation sets can withstand a weight of 60 tons. Additionally the insulation sets are mounted with foam half shells which ensure less heat loss during operation.

A special H-insulation set can be used for connecting the casing pipe from single to twin lines.

3.8 Uponor Ecoflex chamber



FP0000241

Without load distribution the chamber can, with a 50 cm sand cover, withstand a short-term load of 3000 kg (6000 kg/m²) - e.g. a tractor crossing. The chamber lid can withstand a continuous load of up to 500 kg (1000 kg/m²), e.g. a parked car.

Uponor connecting chambers are designed for pipe joints that cannot be made with an Uponor insulation kit. The chamber is made of polyethylene and, on the inside, it is coated with insulation to minimize heat loss. The chamber has a watertight structure and is suitable for all pipe dimensions (casing pipe size 140, 175, 200 and 250 mm).

3.9 Uponor Ecoflex house connection elbow single/twin



FP0000240

Uponor offers the pre-insulated Ecoflex house connection elbow to simplify house entry through the floor slab with minimal bending radius. It consists of polyurethane foamed PE-Xa medium pipes with PE-HD outer jacket.

House connection elbows are available for single pipes in dimensions 40 - 75 mm, and for twin pipes in dimensions 25 - 75 mm.

Dimensions

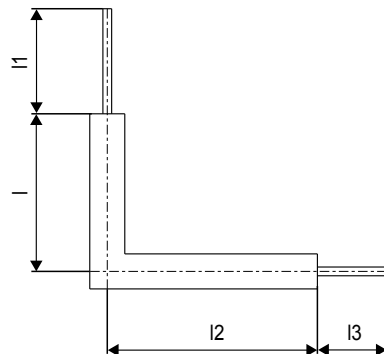

ZD0000075

I	I1	I2	I3
900	200	1200	200

3.10 Uponor Ecoflex wall ducts

Wall sleeve set NPW



PH0000156

The wall sleeve set is non-pressure waterproof (NPW) and can be used for the inlet through building foundation above ground water level. The wall sleeve is mounted in place when the foundations are cast or is installed in a hole drilled afterwards.

The set contains a wall sleeve and a shrink sleeve.

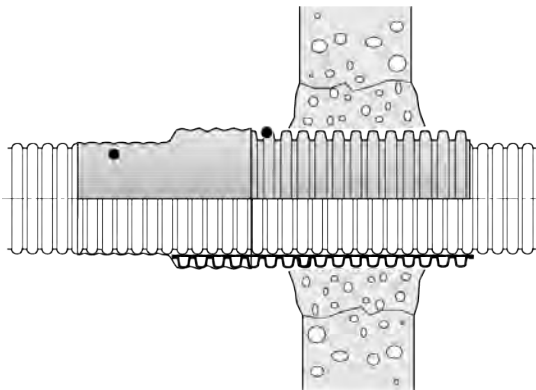

SD0000148

The shrink sleeve prevents water from leaking into the foundations between the pipe and the wall sleeve.

Dimensions

Jacket pipe size [mm]	Sleeve pipe OD [mm]
68/90	110
140	200
175/200	250
250	315

Wall through sealing NPW



PH0000157

The non-pressure waterproof (NPW) wall through sealing efficiently seals the inlet in a concrete structure and prevents moisture from entering the building. Radon sealing has also been tested.

The set contains the wall through sealing and the clamping ring.

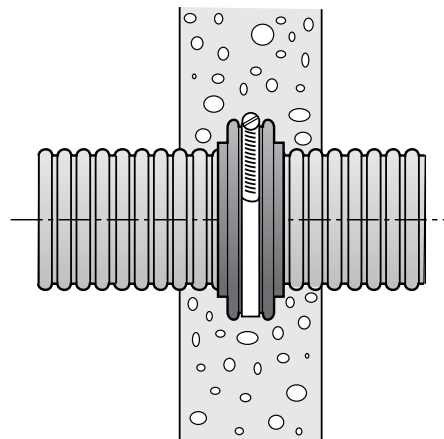

SD0000148

Dimensions

Jacket pipe size [mm]	Outer diameter of sealing [mm]*
140	190
175	225
200	250
250	300

* Excluding 5 mm for tensioning screw.

Uponor Ecoflex wall seal PWP

Wall seal PWP



PH0000158

A pressure waterproof PWP Uponor wall seal must be used wherever water at pressure is to be expected, e.g. because of high ground water level. It can either be used directly in a coated drill hole into waterproof concrete, or in a fibre cement pipe that is concreted or bricked into place.

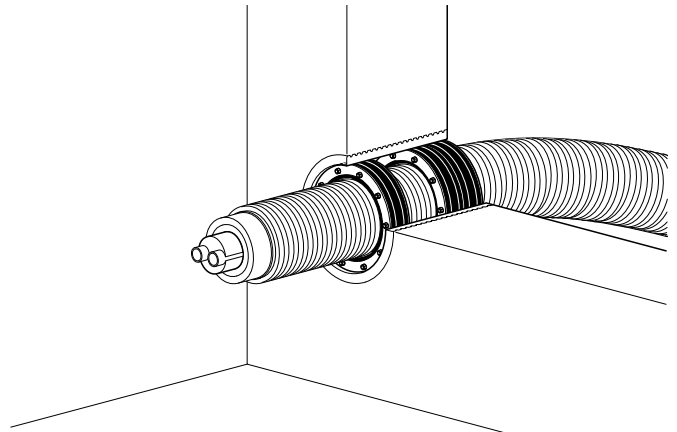

SD0000151

Jacket pipe size [mm]	Core hole [mm]
68	125
140	200
175	250
200	300
250	350

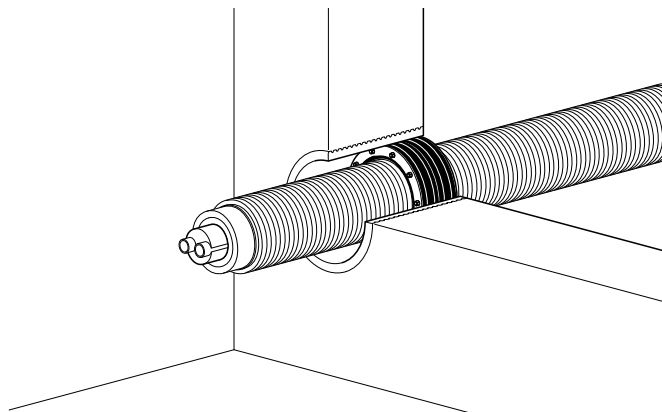

SD0000150

Additional insert PWP



PH0000159

If it is not possible to introduce the jacket pipe perpendicularly into the wall duct, use the Uponor Ecoflex additional insert to disperse any possible stresses.

Epoxy resin set PWP

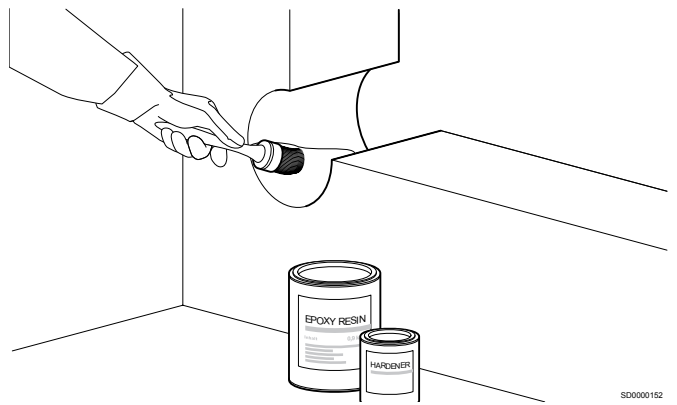

SD0000152

The walls of the tapping drill hole must be coated with epoxy resin before installing the Uponor Ecoflex wall seal PWP.



PH0000160

Fibre cement pipe PWP



PH0000161

The wall seal PWP can also be mounted into an Uponor Ecoflex fibre cement pipe PWP.

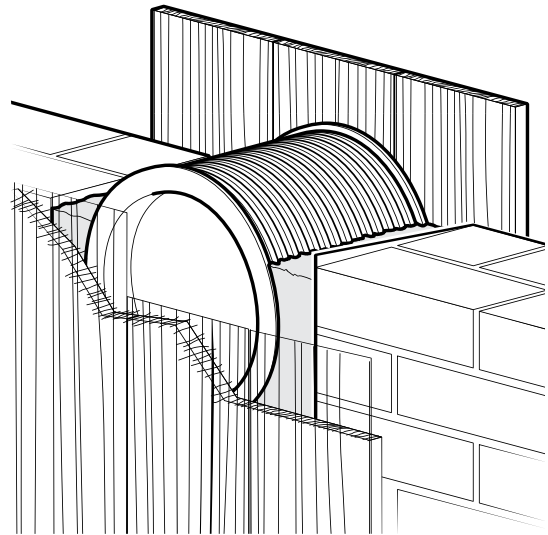

SD0000153

The fibre cement pipe can be fixed in a brick wall or poured in a concrete wall.

3.11 Additional accessories



Note

For more detailed information, product range and documentation please visit the Uponor website: www.uponor.com.

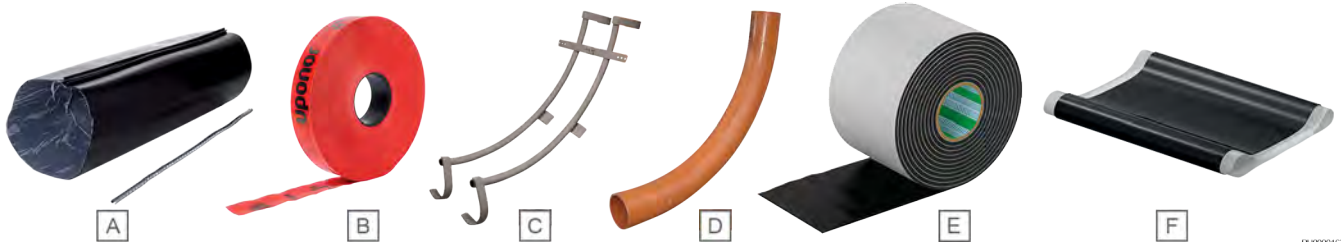

PH0000162

Item	Description	Additional information
A	Ecoflex repair sleeve	Damaged jacket pipes can be repaired easily and reliably with the Uponor repair shrink sleeve.
B	Ecoflex trench warning tape	The Uponor Ecoflex trench warning tape is laid above the flexible, pre-insulated pipe to mark and identify it.
C	Ecoflex pipe bend support	For supporting pipes exactly into place in base floor feed-throughs. Several pipe bend supports can be joined together side by side.
D	Ecoflex conduit angle	The conduit angle is used as a casing pipe when leading insulated pipe elements into buildings. Material is PVC plastic.
E	Ecoflex shrink tape	Shrinkable tape used for sealing damaged casing pipes
F	Ecoflex shrink sleeve	Seal casing pipe with chamber or other casing outlets

Uponor Ecoflex Supra PLUS sets



PH0000155

Item	Description
A	Ecoflex Supra PLUS T-joint set
B	Ecoflex Supra PLUS connection and end set
C	Ecoflex Supra PLUS straight joint set

Uponor Ecoflex Supra Standard sets



PH0000163

Item	Description
A	Ecoflex jacket joint set
B	Ecoflex tee insulation set plus Supra Standard cable set S2
C	Ecoflex Supra Standard connection and end termination
D	Ecoflex jacket joint set plus Supra Standard cable set S1

4 Planning/design

4.1 Design basics

Lining up the elements

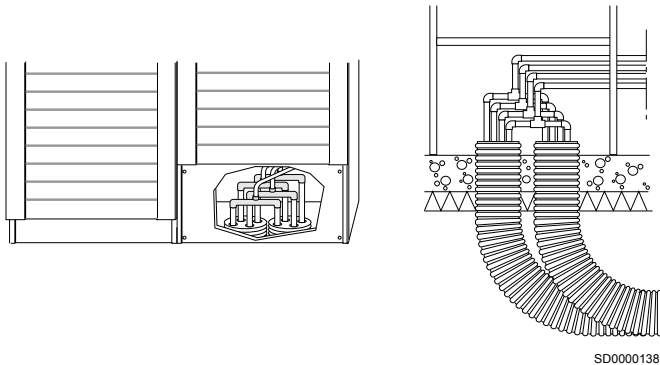

The flexibility of the piping system allows for planning the trenches flexibly and taking the environment into account. When the pipe element is led into the building, the selection of the entry location must take into account the space requirements of the pipe bending radius.

Linking

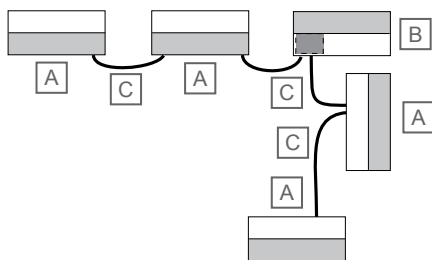

Item	Description
A	Heating user
B	Heating central
C	Ecoflex Quattro

The implementation of the most efficient system in terms of operation and installation costs is best done using twin pipes or pipes that evenly combine heating and warm tap water medium pipes, like Ecoflex Quattro. Quattro products have lower thermal losses compared to corresponding combination of Thermo or Aqua pipes and are therefore particularly well suited for installing in terraced houses and small apartment buildings.

The number of joints in the ground can be reduced for small buildings by using the linking technique. The technique is particularly well suited to locations where houses are lined up and the dimensions of the Quattro products are sufficient for the capacity needed. The floor space required by Quattro is very small, allowing for linking joints to be made inside the apartments. For example, the raised base of the hallway cabinet can be used as the linking space.

Building-specific lines

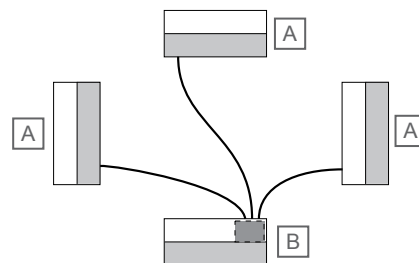

Item	Description
A	Heating user
B	Heating central

In properties consisting of several buildings, straight connections from the house to the boiler room are recommended if the heating central is located in a central location. Installation between buildings is fast straight off the coil and no connections are required. Trenches do not have to be kept open for pressure testing. The used pipe sizes are small which allows for the use of Twin pipes for heating and warm tap water or Quattro pipes.

Combining products

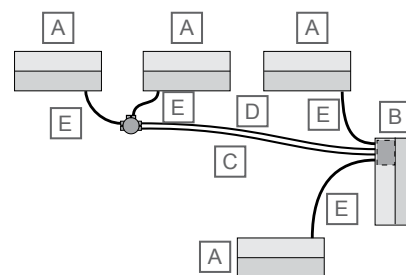

Item	Description
A	Heating user
B	Heating central
C	Uponor Ecoflex VIP Thermo / Thermo / Varia Twin
D	Uponor Ecoflex VIP Aqua / Aqua Twin
E	Uponor Ecoflex Quattro

Large medium pipes of Ecoflex Quattro and Aqua Twin make it possible to use them for efficient installations even in big construction objects. With optimum combination of products it is possible to achieve lower heat losses and better installation efficiency.

4.2 Planning Ecoflex Supra PLUS

Electrical planning

Note

$L1 + L2 + L3 < \text{longest permitted length } 150\text{m!}$

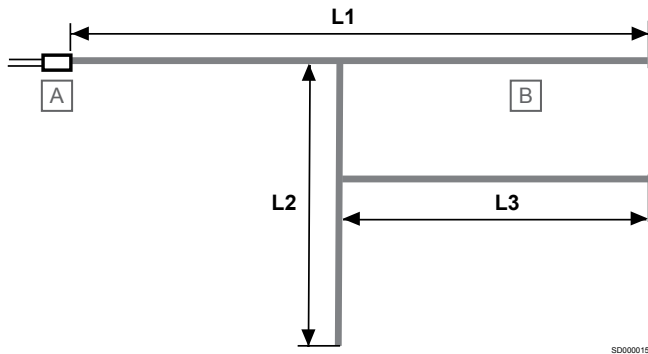

Item	Description
A	Supply cable 230 V AC
B	Uponor Ecoflex Supra PLUS

Supra PLUS must be installed and protected according to local regulations. Due to the structure of parallel connections, the self-regulating frost protection cable also functions as a possible feed cable for branches and therefore the pipe network can consist of several branches. It is important to note that the total length of the pipe network supplied from one point must not exceed the longest permitted installation length for the frost protection cable.

The longest permitted installation length:

- 100 m for a 10 A fuse
- 150 m for a 16 A fuse

It is recommended to group various short pipes into one circuit. Each circuit must have its own shielding.

Circuit length

The lengths of the pipes are summed up and 0,5 m is added for each connection and termination and 1,5 m is added per branch. Also reserve enough cable to wrap around additional sources of thermal loss (valves, feed-troughs, etc.).

Protection

Cable circuits

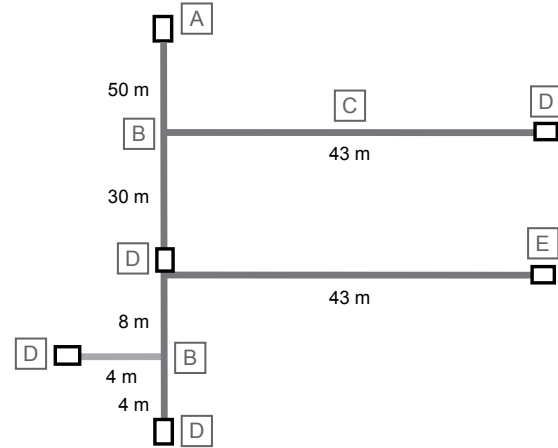

Item	Description
A	Supply point, length 126 m
B	T-branch
C	Uponor Ecoflex Supra PLUS
D	End termination
E	Supply point, length 62 m

The total length of the frost protection cable is used to determine the number and size of safety devices and the number of independent pipe circuits. For example, the piping is 182 m long. The total length including branches and the reservation for connection is 188 m.

Calculation examples

The following two cable circuits are selected as examples:

A) $(50 + 43 + 30) \text{ m} + (1,5 + 0,5 + 0,5 + 0,5) \text{ m} = 126 \text{ m}$, a total of 126 m for a safety device of 16 A

E) $(43 + 8 + 4 + 4) \text{ m} + (1,5 + 0,5 + 0,5 + 0,5) \text{ m} = 62 \text{ m}$, a total of 62 m for a safety device of 10 A

Cable circuits RK1

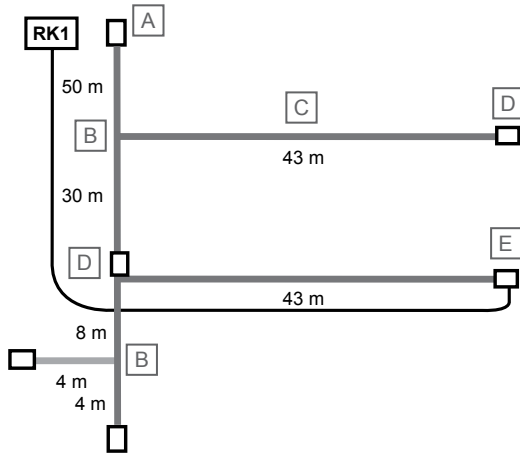

SD0000158

Item	Description
A	Supply point, length 126 m
B	T-branch
C	Uponor Ecoflex Supra PLUS
D	End termination
E	Supply point, length 62 m

If supply cannot be organised from two directions, from different fuse boxes, a ground cable must be installed in the trench for the second supply point when supply is from RK 1. Supply point 2 can also be transferred to point 3 and supply for the circuit can be organised through a centre feed. Use branch tees and supplies by changing one of the branches to a supply cable.

Calculation examples

The following two cable circuits are selected as examples:

A) $(50 + 43 + 30) \text{ m} + (1,5 + 0,5 + 0,5 + 0,5) \text{ m} = 126 \text{ m}$, a total of 126 m for a safety device of 16 A

E) $(43 + 8 + 4 + 4) \text{ m} + (1,5 + 0,5 + 0,5 + 0,5) \text{ m} = 62 \text{ m}$, a total of 62 m for a safety device of 10 A

Example – connection for 450 m pipeline

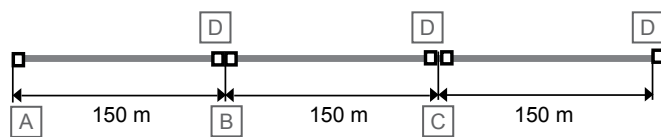

SD0000158

Item	Description
A	Supply point 1
B	Supply point 2
C	Supply point 3
D	End termination

The ground cable must be laid in the trench to supply points B and C. The circuits must be kept separate from each other, not protected by the same fuse (in this case 3 x 16 A).

The cable of Supra PLUS pipe is a parallel-fed frost protection cable. The conductors must not be connected at the cable ends, as this would short circuit the cable.

The Supra PLUS cable ends (each 150 m) needs to be connected with a terminator.

Supra PLUS Cable Set S1



RF0000278

Supply cable - frost protection cable joint and cable end termination
Frost protection cable - frost protection cable joint.

Supra PLUS Cable Set S2



RF0000279

Frost protection cable tee and cable end termination.

Each package includes detailed installation instructions for the installer and the electrician, and it's important to familiarize with the instructions prior to the installation. The packages do not include the medium pipe couplings.

Overcurrent protection devices

- Plug fuse 10 A or 16 A, slow
- Circuit breakers (automatic) G or K curve
- Residual-current device

The final circuit supplying the frost protection cable must be protected with a residual current operated device with a tripping current of 30 mA.

Supply cable dimensioning

The supply cables feeding Supra PLUS pipes must be dimensioned taking account of the general regulations, the ratings of the protection devices and any voltage losses. The cable cross section and structure must be selected and the cable installed in accordance with the regulations, as with any other electrical devices. The cable cross-section area must be selected based on the protection device's rated value.

Control unit

The frost protection cable of a Supra PLUS pipe is controlled with a control unit included in the connection and ending package. The control unit is an electronic regulator designed for controlling the Supra PLUS water pipe equipped with a self-regulating frost protection cable. It includes a main switch with an indicator light, allowing the cable's power to be switched on/off.

The control unit has two different function modes: thermostat control mode with a temperature sensor, or timer control mode based on a fixed time period. The control method can be selected by lifting the control knob and turning it to the desired setting. The thermostat control mode can be used irrespective of if the pipeline has been installed completely underground or above ground.

The thermostat controls the cable based on sensor information, which means that the conditions must be the same throughout the entire pipeline length. Use the timer when the conditions vary over the pipeline length. Choose the 'on' periods according to the prevailing conditions.

4.3 Planning Ecoflex Supra Standard

Electrical planning

The system must be installed and protected according to valid electrical safety regulations. In order to ease planning and use, each circuit must only have one cable type connected to it. Due to the structure of parallel connections, the frost protection cable also functions as a possible feed cable for branches and therefore the pipe network can consist of several branches. An installation plan and technical drawings must be drawn for all frost protection cable installations.

Plans are drawn by a qualified electrical planner or contractor according to the manufacturer's instructions. The technical drawing must include the following information: the type of frost protection cable, its capacity, length, placement in the heated location, the number of frost protection cables in the installation location and the length and type of the supply cable.

Supra Standard pipes are always controlled using the Uponor Ecoflex Supra Standard thermostat ETN4.

Circuit length

Note

$L1 + L2 + L3 + 1,5 \text{ m} + 0,5 \text{ m} = L$, circuit length used to determine the correct connection option.

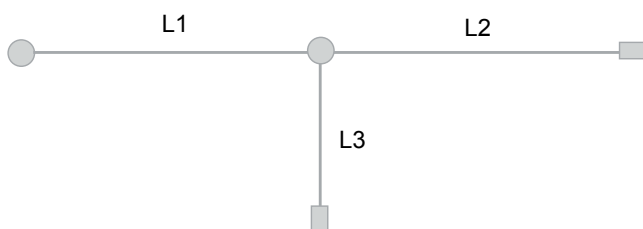

The lengths of the pipes are added up. Add 0,5 m for both connection and termination and 1,5 m for each branching. Also add enough cable to wrap around additional sources of thermal loss (valves, inlets, etc.). In extensive networks, lines should be grouped in suitable connection circuits so that the cable provides the required output per meter W/m (see the heating capacity charts).

Different connection circuits can be controlled using the same regulator if the total output does not exceed the maximum load capacity $P = 6,400 \text{ W}$. When controlling several different control circuits, the sensor is installed on one circuit. All circuits are then controlled based on the information provided by the sensor. The adequacy of the power must be taken into account for all circuits, if the temperature varies considerably from one circuit to the next.

Example

A pipeline with a total length of 120 m and dimensions 32/90 is installed on a pipe bridge outside in a location susceptible to wind chill, where the dimensioning temperature must be $-50 \text{ }^\circ\text{C}$. The required power is then 14 W/m. Connection voltage is selected at 230 V and cable 2 x 0,48 W/m (yellow cable). By connecting 2 x 0,48 W/m in parallel + Cu-return achieves a power of 15 W/m.

Protection

The total length of the pipeline determines the number of independent connection circuits, the number of safety devices and their dimensioning. Protection takes place using a plug fuse 10 A or 16 A, a line protection switch (automatic fuse) G or K curve and residual current operated device 30 mA, also suitable for use as the residual current operated device on pipelines containing flammable fluids.

Supra Standard connection parts

The Supra Standard system contains complete cable connection sets for the connection, branching and extension of pipes. The sets do not contain connectors for the medium pipes.

Connection, extension and termination, Cable set S1

- Uponor Ecoflex Supra Standard thermostat ETN4
- The required electrical parts
- End caps

T-branch, extension and termination, cable set S2

- Branch tee insulation chute
- The required electrical parts

Detailed instructions for both installer and electrician are separate IM documents, which can be downloaded from local Uponor website.

Dimensioning the supply cable

Supply cables for Uponor Ecoflex Supra Standard pipes must be dimensioned taking into account general regulations, the dimensioning of the safety devices and possible voltage drops. The selection and installation of the cable cross section and structure must be carried out according to regulations, as it is done with all other electrical equipment. The cable cross section must be selected according to the rated voltage of the safety device.

Operation, maintenance and pipeline repairs

The maximum permitted continuous operation temperature of the frost protection cable is $70 \text{ }^\circ\text{C}$ and must not be exceeded. The frost protection cable does not require maintenance. The frost protection cable must be switched off and protected from mechanical damage during any repairs to the pipeline. After repairs, a new test log must be filled in.

Heating capacity charts

Yellow cable 2 x 0,48 Ω/m + Cu, 230 V



D0000143

Item	Description
A	Capacity [W/m]
B	Cable length [m]
C	2 x 0,48 Ω/m series
D	0,48 Ω/m + Cu-return
E	2 x 0,48 Ω/m parallel + Cu-return

Yellow cable 2 x 0,48 Ω/m + Cu, 400 V

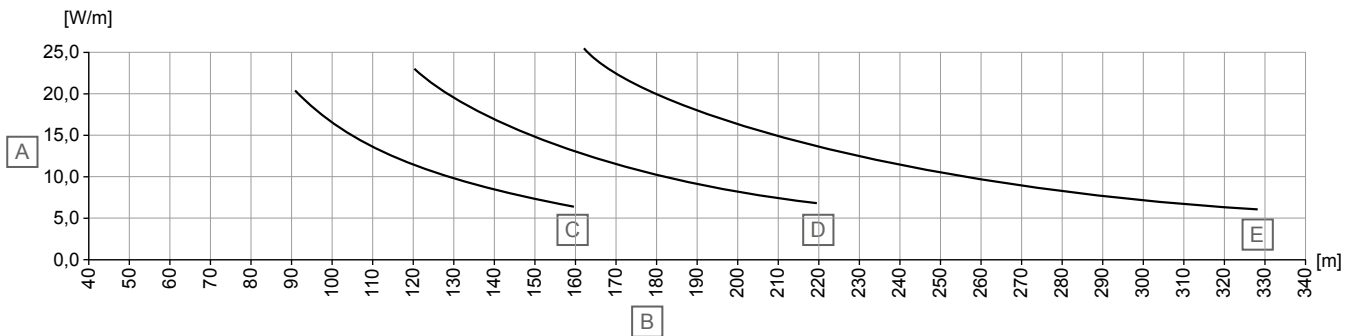

D0000144

Item	Description
A	Capacity [W/m]
B	Cable length [m]
C	2 x 0,48 Ω/m series
D	0,48 Ω/m + Cu-return
E	2 x 0,48 Ω/m parallel + Cu-return

White cable 2 x 0,05 Ω/m + Cu, 230 V

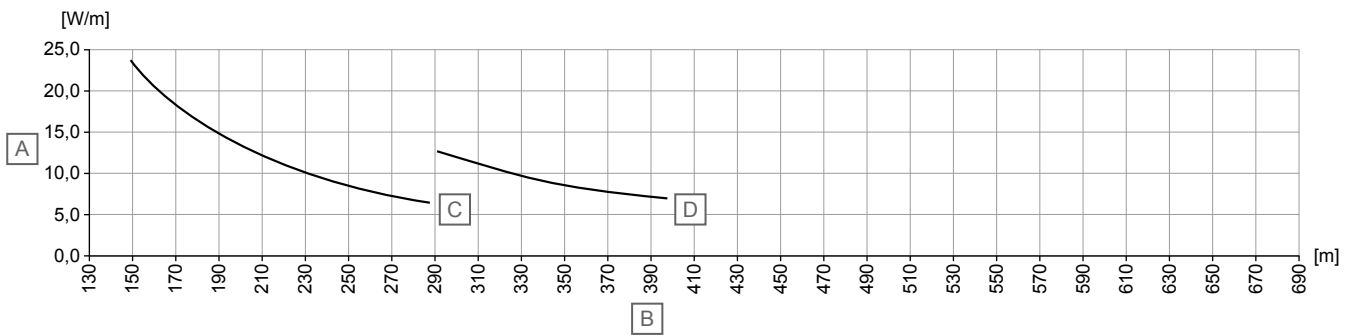

D10000145

Item	Description
A	Capacity [W/m]
B	Cable length [m]
C	2 x 0,05 Ω/m series
D	0,05 Ω/m + Cu-return

White cable 2 x 0,05 Ω/m + Cu, 400 V

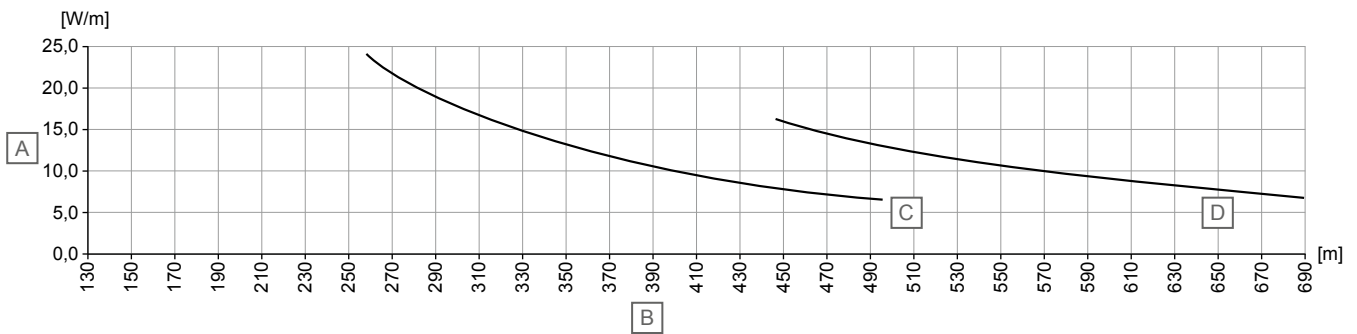

D10000146

Item	Description
A	Capacity [W/m]
B	Cable length [m]
C	2 x 0,05 Ω/m series
D	0,05 Ω/m + Cu-return

5 Dimensioning

5.1 Heating dimensioning diagram

Compared to the steel pipes, a considerably larger pressure loss per meter can be allowed for plastic heating pipes as there is no risk of erosion. In the diagram the recommended area has been darkened.

The diagram includes rated values $\Delta\vartheta$ 20, 25, 30 and 45 for temperature difference between flow and return. The pipe size can also be selected according to the mass flow rate which can be calculated using the following formula.

$$\dot{m} = \frac{Q}{\Delta\vartheta \cdot c_p}$$

where:

\dot{m} = mass flow rate kg/s

Q = heating power kW

$\Delta\vartheta$ = temperature difference K

c_p = water specific heat capacity, 4,19 kJ/kgK

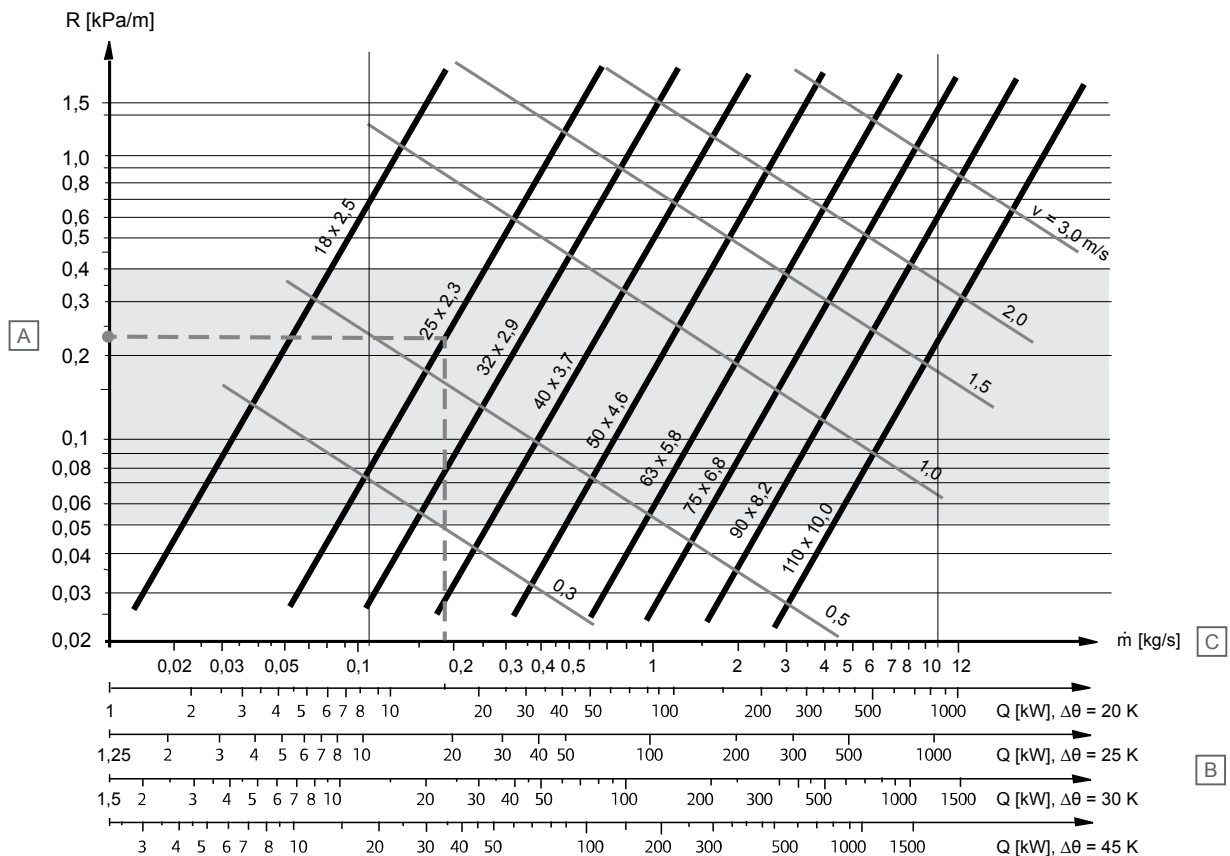

Item	Description
A	Pipe friction resistance R [kPa/m]
B	Heating power Q [kW] at given temperature difference $\Delta\theta$ [K]
C	Mass flow rate \dot{m} [kg/s]

The diagram is based on:

- Water temperature at +55 °C.
- Pressure loss includes 20 % additional friction resistance for fittings.
- PE-X pipe smoothness factor 0,0005 mm.

Approximate heating power - requirements [W/m³]

	One-family house	Terraced house	Apartment building
new	12 – 18	12 – 18	10 – 16
old	18 – 26	18 – 26	16 – 23

Dimensioning example

The task is to select heating pipes and the boiler house.

The surface area of the building is 300 m² and the room height is 2,9 m. The building has normal radiator heating with flow water temperature $\vartheta_f = +70$ °C and return water $\vartheta_r = +40$ °C.

Step 1

Determine the requirement for heating power (the volume of the building times the specific capacity requirement).

$$F = 300 \text{ m}^2 \times 2,9 \text{ m} \times 25 \text{ W/m}^3 = 21750 \text{ W} \approx 22 \text{ kW}$$

Step 2

Determine the correct $\Delta\theta$ -axis or mass flow rate.

$$\Delta\theta = (\theta_r - \theta_i) = 30 \text{ K}$$

Step 3

Select the correct pipe size from the recommended pressure loss area set out in the image.

$$\Delta\theta = 30 \text{ K and } Q = 22 \text{ kW} \Rightarrow \text{Pipe size } \varnothing 25/20,4 \text{ mm}$$

5.2 Dimensioning table for heating pipe, PN 6 (SDR 11)

Spread										
$\Delta\theta = 10 \text{ K}$	$\Delta\theta = 15 \text{ K}$	$\Delta\theta = 20 \text{ K}$	$\Delta\theta = 25 \text{ K}$	$\Delta\theta = 30 \text{ K}$	$\Delta\theta = 35 \text{ K}$	$\Delta\theta = 40 \text{ K}$	Mass flow rate \dot{m}	Pipe type/ $\Delta p/v$	Pipe type/ $\Delta p/v$	Pipe type/ $\Delta p/v$
10 kW	15 kW	20 kW	25 kW	30 kW	35 kW	40 kW	860 kg/h	25/20,4 0,3016 kPa/m 0,740 m/s	32/26,2 0,0909 kPa/m 0,449 m/s	40/32,6 0,0319 kPa/m 0,290 m/s
20 kW	30 kW	40 kW	50 kW	60 kW	70 kW	80 kW	1720 kg/h	32/26,2 0,3157 kPa/m 0,897 m/s	40/32,6 0,1106 kPa/m 0,579 m/s	50/40,8 0,0377 kPa/m 0,370 m/s
30 kW	45 kW	60 kW	75 kW	90 kW	105 kW	120 kW	2581 kg/h	32/26,2 0,6553 kPa/m 1,346 m/s	40/32,6 0,2294 kPa/m 0,869 m/s	50/40,8 0,0782 kPa/m 0,555 m/s
40 kW	60 kW	80 kW	100 kW	120 kW	140 kW	160 kW	3441 kg/h	40/32,6 0,3853 kPa/m 1,159 m/s	50/40,8 0,1312 kPa/m 0,740 m/s	63/51,4 0,0433 kPa/m 0,466 m/s
50 kW	75 kW	100 kW	125 kW	150 kW	175 kW	200 kW	4301 kg/h	50/40,8 0,1961 kPa/m 0,925 m/s	63/51,4 0,0647 kPa/m 0,583 m/s	75/61,4 0,0276 kPa/m 0,408 m/s
60 kW	90 kW	120 kW	150 kW	180 kW	210 kW	240 kW	5161 kg/h	50/40,8 0,2725 kPa/m 1,110 m/s	63/51,4 0,0899 kPa/m 0,699 m/s	75/61,4 0,0383 kPa/m 0,490 m/s
70 kW	105 kW	140 kW	175 kW	210 kW	245 kW	280 kW	6022 kg/h	50/40,8 0,3599 kPa/m 1,295 m/s	63/51,4 0,1186 kPa/m 0,816 m/s	75/61,4 0,0505 kPa/m 0,572 m/s
80 kW	120 kW	160 kW	200 kW	240 kW	280 kW	320 kW	6882 kg/h	63/51,4 0,1510 kPa/m 0,932 m/s	75/61,4 0,0643 kPa/m 0,653 m/s	90/73,6 0,0269 kPa/m 0,455 m/s
90 kW	135 kW	180 kW	225 kW	270 kW	315 kW	360 kW	7742 kg/h	63/51,4 0,1867 kPa/m 1,049 m/s	75/61,4 0,0795 kPa/m 0,735 m/s	90/73,6 0,0333 kPa/m 0,512 m/s
100 kW	150 kW	200 kW	250 kW	300 kW	350 kW	400 kW	8602 kg/h	63/51,4 0,2259 kPa/m 1,165 m/s	75/61,4 0,0961 kPa/m 0,817 m/s	90/73,6 0,0402 kPa/m 0,568 m/s
110 kW	165 kW	220 kW	275 kW	330 kW	385 kW	440 kW	9462 kg/h	63/51,4 0,2684 kPa/m 1,282 m/s	75/61,4 0,1142 kPa/m 0,898 m/s	90/73,6 0,0478 kPa/m 0,625 m/s
120 kW	180 kW	240 kW	300 kW	360 kW	420 kW	480 kW	10323 kg/h	75/61,4 0,1336 kPa/m 0,980 m/s	90/73,6 0,0559 kPa/m 0,682 m/s	110/90,0 0,0213 kPa/m 0,456 m/s
130 kW	195 kW	260 kW	325 kW	390 kW	455 kW	520 kW	11183 kg/h	75/61,4 0,1544 kPa/m 1,062 m/s	90/73,6 0,0646 kPa/m 0,739 m/s	110/90,0 0,0246 kPa/m 0,494 m/s

Spread										
$\Delta\theta = 10\text{ K}$	$\Delta\theta = 15\text{ K}$	$\Delta\theta = 20\text{ K}$	$\Delta\theta = 25\text{ K}$	$\Delta\theta = 30\text{ K}$	$\Delta\theta = 35\text{ K}$	$\Delta\theta = 40\text{ K}$	Mass flow rate \dot{m}	Pipe type/ $\Delta p/v$	Pipe type/ $\Delta p/v$	Pipe type/ $\Delta p/v$
140 kW	210 kW	280 kW	350 kW	420 kW	490 kW	560 kW	12043 kg/h	75/61,4 0,1766 kPa/m 1,143 m/s	90/73,6 0,0739 kPa/m 0,796 m/s	110/90,0 0,0281 kPa/m 0,532 m/s
150 kW	225 kW	300 kW	375 kW	450 kW	525 kW	600 kW	12903 kg/h	75/61,4 0,2000 kPa/m 1,225 m/s	90/73,6 0,0837 kPa/m 0,853 m/s	110/90,0 0,0318 kPa/m 0,570 m/s
160 kW	240 kW	320 kW	400 kW	480 kW	560 kW	640 kW	13763 kg/h	75/61,4 0,2248 kPa/m 1,307 m/s	90/73,6 0,0940 kPa/m 0,909 m/s	110/90,0 0,0358 kPa/m 0,608 m/s
170 kW	255 kW	340 kW	425 kW	510 kW	595 kW	680 kW	14624 kg/h	90/73,6 0,1049 kPa/m 0,966 m/s	110/90,0 0,0399 kPa/m 0,646 m/s	125/102,0 0,0217 kPa/m 0,501 m/s
180 kW	270 kW	360 kW	450 kW	540 kW	630 kW	720 kW	15484 kg/h	90/73,6 0,1164 kPa/m 1,023 m/s	110/90,0 0,0442 kPa/m 0,684 m/s	125/102,0 0,0240 kPa/m 0,531 m/s
190 kW	285 kW	380 kW	475 kW	570 kW	665 kW	760 kW	16344 kg/h	90/73,6 0,1283 kPa/m 1,080 m/s	110/90,0 0,0488 kPa/m 0,722 m/s	125/102,0 0,0265 kPa/m 0,560 m/s
200 kW	300 kW	400 kW	500 kW	600 kW	700 kW	800 kW	17204 kg/h	90/73,6 0,1408 kPa/m 1,137 m/s	110/90,0 0,0535 kPa/m 0,760 m/s	125/102,0 0,0290 kPa/m 0,590 m/s
210 kW	315 kW	420 kW	525 kW	630 kW	735 kW	840 kW	18065 kg/h	90/73,6 0,1538 kPa/m 1,194 m/s	110/90,0 0,0584 kPa/m 0,798 m/s	125/102,0 0,0317 kPa/m 0,619 m/s
220 kW	330 kW	440 kW	550 kW	660 kW	770 kW	880 kW	18925 kg/h	90/73,6 0,1673 kPa/m 1,251 m/s	110/90,0 0,0636 kPa/m 0,836 m/s	125/102,0 0,0345 kPa/m 0,649 m/s
230 kW	345 kW	460 kW	575 kW	690 kW	805 kW	920 kW	19785 kg/h	90/73,6 0,1813 kPa/m 1,307 m/s	110/90,0 0,0689 kPa/m 0,874 m/s	125/102,0 0,0374 kPa/m 0,678 m/s
240 kW	360 kW	480 kW	600 kW	720 kW	840 kW	960 kW	20640 kg/h	110/90,0 0,0744 kPa/m 0,912 m/s	125/102,0 0,0404 kPa/m 0,708 m/s	-
250 kW	375 kW	500 kW	625 kW	750 kW	875 kW	1000 kW	21505 kg/h	110/90,0 0,0801 kPa/m 0,950 m/s	125/102,0 0,0435 kPa/m 0,737 m/s	-
260 kW	390 kW	520 kW	650 kW	780 kW	910 kW	1040 kW	22366 kg/h	110/90,0 0,0860 kPa/m 0,988 m/s	125/102,0 0,0467 kPa/m 0,766 m/s	-
270 kW	405 kW	540 kW	675 kW	810 kW	945 kW	1080 kW	23220 kg/h	110/90,0 0,0921 kPa/m 1,026 m/s	125/102,0 0,0500 kPa/m 0,796 m/s	-
280 kW	420 kW	560 kW	700 kW	840 kW	980 kW	1120 kW	24086 kg/h	110/90,0 0,0984 kPa/m 1,064 m/s	125/102,0 0,0534 kPa/m 0,825 m/s	-
290 kW	435 kW	580 kW	725 kW	870 kW	1015 kW	1160 kW	24946 kg/h	110/90,0 0,1048 kPa/m 1,102 m/s	125/102,0 0,0569 kPa/m 0,855 m/s	-

Spread										
$\Delta\theta = 10\text{ K}$	$\Delta\theta = 15\text{ K}$	$\Delta\theta = 20\text{ K}$	$\Delta\theta = 25\text{ K}$	$\Delta\theta = 30\text{ K}$	$\Delta\theta = 35\text{ K}$	$\Delta\theta = 40\text{ K}$	Mass flow rate \dot{m}	Pipe type/ $\Delta p/v$	Pipe type/ $\Delta p/v$	Pipe type/ $\Delta p/v$
300 kW	450 kW	600 kW	750 kW	900 kW	1050 kW	1200 kW	25806 kg/h	110/90,0 0,1115 kPa/m 1,140 m/s	125/102,0 0,0605 kPa/m 0,884 m/s	-
310 kW	465 kW	620 kW	775 kW	930 kW	1085 kW	1240 kW	26667 kg/h	110/90,0 0,1183 kPa/m 1,178 m/s	125/102,0 0,0642 kPa/m 0,914 m/s	-
320 kW	480 kW	640 kW	800 kW	960 kW	1120 kW	1280 kW	27527 kg/h	110/90,0 0,1253 kPa/m 1,216 m/s	125/102,0 0,0680 kPa/m 0,943 m/s	-
330 kW	495 kW	660 kW	825 kW	990 kW	1155 kW	1320 kW	28387 kg/h	110/90,0 0,1325 kPa/m 1,254 m/s	125/102,0 0,0719 kPa/m 0,973 m/s	-
340 kW	510 kW	680 kW	850 kW	1020 kW	1190 kW	1360 kW	29247 kg/h	110/90,0 0,1398 kPa/m 1,292 m/s	125/102,0 0,0759 kPa/m 1,002 m/s	-
350 kW	525 kW	700 kW	875 kW	1050 kW	1225 kW	1400 kW	30108 kg/h	125/102,0 0,0799 kPa/m 1,032 m/s	-	-
360 kW	540 kW	720 kW	900 kW	1080 kW	1260 kW	1440 kW	30968 kg/h	125/102,0 0,0841 kPa/m 1,061 m/s	-	-
370 kW	555 kW	740 kW	925 kW	1110 kW	1295 kW	1480 kW	31828 kg/h	125/102,0 0,0884 kPa/m 1,091 m/s	-	-
380 kW	570 kW	760 kW	950 kW	1140 kW	1330 kW	1520 kW	32688 kg/h	125/102,0 0,0928 kPa/m 1,120 m/s	-	-
390 kW	585 kW	780 kW	975 kW	1170 kW	1365 kW	1560 kW	33548 kg/h	125/102,0 0,0973 kPa/m 1,150 m/s	-	-
400 kW	600 kW	800 kW	1000 kW	1200 kW	1400 kW	1600 kW	34409 kg/h	125/102,0 0,1018 kPa/m 1,179 m/s	-	-
410 kW	615 kW	820 kW	1025 kW	1230 kW	1435 kW	1640 kW	35269 kg/h	125/102,0 0,1065 kPa/m 1,209 m/s	-	-
420 kW	630 kW	840 kW	1050 kW	1260 kW	1470 kW	1680 kW	36129 kg/h	125/102,0 0,1112 kPa/m 1,238 m/s	-	-
430 kW	645 kW	860 kW	1075 kW	1290 kW	1505 kW	1720 kW	36989 kg/h	125/102,0 0,1161 kPa/m 1,268 m/s	-	-
440 kW	660 kW	880 kW	1100 kW	1320 kW	1540 kW	1760 kW	37849 kg/h	125/102,0 0,1210 kPa/m 1,297 m/s	-	-
450 kW	675 kW	900 kW	1125 kW	1350 kW	1575 kW	1800 kW	38710 kg/h	125/102,0 0,1261 kPa/m 1,327 m/s	-	-

5.3 Quick dimensioning table heating pipe, PN 10 (SDR 7,4)

Spread										
$\Delta\theta = 10\text{ K}$	$\Delta\theta = 15\text{ K}$	$\Delta\theta = 20\text{ K}$	$\Delta\theta = 25\text{ K}$	$\Delta\theta = 30\text{ K}$	$\Delta\theta = 35\text{ K}$	$\Delta\theta = 40\text{ K}$	Mass flow rate \dot{m}	Pipe type/ $\Delta p/v$	Pipe type/ $\Delta p/v$	Pipe type/ $\Delta p/v$
10 kW	15 kW	20 kW	25 kW	30 kW	35 kW	40 kW	860 kg/h	25/18 0,5498 kPa/m 0,950 m/s	32/23,2 0,1628 kPa/m 0,572 m/s	40/29 0,0558 kPa/m 0,366 m/s
20 kW	30 kW	40 kW	50 kW	60 kW	70 kW	80 kW	1720 kg/h	32/23,2 0,5660 kPa/m 1,144 m/s	40/29 0,1939 kPa/m 0,732 m/s	50/36,2 0,0669 kPa/m 0,470 m/s
30 kW	45 kW	60 kW	75 kW	90 kW	105 kW	120 kW	2581 kg/h	40/29 0,4024 kPa/m 1,098 m/s	50/36,2 0,1388 kPa/m 0,705 m/s	63/45,8 0,0449 kPa/m 0,440 m/s
40 kW	60 kW	80 kW	100 kW	120 kW	140 kW	160 kW	3441 kg/h	50/36,2 0,2330 kPa/m 0,940 m/s	63/45,8 0,0753 kPa/m 0,587 m/s	75/54,4 0,0330 kPa/m 0,416 m/s
50 kW	75 kW	100 kW	125 kW	150 kW	175 kW	200 kW	4301 kg/h	50/36,2 0,3484 kPa/m 1,175 m/s	63/45,8 0,1126 kPa/m 0,734 m/s	75/54,4 0,0493 kPa/m 0,520 m/s
60 kW	90 kW	120 kW	150 kW	180 kW	210 kW	240 kW	5161 kg/h	63/45,8 0,1564 kPa/m 0,881 m/s	75/54,4 0,0684 kPa/m 0,624 m/s	90/65,4 0,0283 kPa/m 0,432 m/s
70 kW	105 kW	140 kW	175 kW	210 kW	245 kW	280 kW	6022 kg/h	63/45,8 0,2065 kPa/m 1,028 m/s	75/54,4 0,0903 kPa/m 0,728 m/s	90/65,4 0,0373 kPa/m 0,504 m/s
80 kW	120 kW	160 kW	200 kW	240 kW	280 kW	320 kW	6882 kg/h	63/45,8 0,2628 kPa/m 1,174 m/s	75/54,4 0,1150 kPa/m 0,832 m/s	90/65,4 0,0475 kPa/m 0,576 m/s
90 kW	135 kW	180 kW	225 kW	270 kW	315 kW	360 kW	7742 kg/h	63/45,8 0,3251 kPa/m 1,321 m/s	75/54,4 0,1422 kPa/m 0,936 m/s	90/65,4 0,0587 kPa/m 0,648 m/s
100 kW	150 kW	200 kW	250 kW	300 kW	350 kW	400 kW	8602 kg/h	75/54,4 0,1720 kPa/m 1,040 m/s	90/65,4 0,0710 kPa/m 0,720 m/s	110/79,8 0,0273 kPa/m 0,484 m/s
110 kW	165 kW	220 kW	275 kW	330 kW	385 kW	440 kW	9462 kg/h	75/54,4 0,2043 kPa/m 1,145 m/s	90/65,4 0,0843 kPa/m 0,792 m/s	110/79,8 0,0324 kPa/m 0,532 m/s
120 kW	180 kW	240 kW	300 kW	360 kW	420 kW	480 kW	10323 kg/h	75/54,4 0,2391 kPa/m 1,249 m/s	90/65,4 0,0987 kPa/m 0,864 m/s	110/79,8 0,0379 kPa/m 0,580 m/s
130 kW	195 kW	260 kW	325 kW	390 kW	455 kW	520 kW	11183 kg/h	75/54,4 0,2763 kPa/m 1,353 m/s	90/65,4 0,1140 kPa/m 0,936 m/s	110/79,8 0,0438 kPa/m 0,629 m/s
140 kW	210 kW	280 kW	350 kW	420 kW	490 kW	560 kW	12043 kg/h	90/65,4 0,1303 kPa/m 1,008 m/s	110/79,8 0,0501 kPa/m 0,677 m/s	-
150 kW	225 kW	300 kW	375 kW	450 kW	525 kW	600 kW	12903 kg/h	90/65,4 0,1477 kPa/m 1,080 m/s	110/79,8 0,0567 kPa/m 0,725 m/s	-

Spread										
$\Delta\theta = 10\text{ K}$	$\Delta\theta = 15\text{ K}$	$\Delta\theta = 20\text{ K}$	$\Delta\theta = 25\text{ K}$	$\Delta\theta = 30\text{ K}$	$\Delta\theta = 35\text{ K}$	$\Delta\theta = 40\text{ K}$	Mass flow rate \dot{m}	Pipe type/ $\Delta p/v$	Pipe type/ $\Delta p/v$	Pipe type/ $\Delta p/v$
160 kW	240 kW	320 kW	400 kW	480 kW	560 kW	640 kW	13763 kg/h	90/65,4 0,1659 kPa/m 1,152 m/s	110/79,8 0,0637 kPa/m 0,774 m/s	-
170 kW	255 kW	340 kW	425 kW	510 kW	595 kW	680 kW	14624 kg/h	90/65,4 0,1852 kPa/m 1,224 m/s	110/79,8 0,0711 kPa/m 0,822 m/s	-
180 kW	270 kW	360 kW	450 kW	540 kW	630 kW	720 kW	15484 kg/h	90/65,4 0,2054 kPa/m 1,296 m/s	110/79,8 0,0789 kPa/m 0,870 m/s	-
190 kW	285 kW	380 kW	475 kW	570 kW	665 kW	760 kW	16344 kg/h	110/79,8 0,0870 kPa/m 0,919 m/s	-	-
200 kW	300 kW	400 kW	500 kW	600 kW	700 kW	800 kW	17204 kg/h	110/79,8 0,0954 kPa/m 0,967 m/s	-	-
210 kW	315 kW	420 kW	525 kW	630 kW	735 kW	840 kW	18065 kg/h	110/79,8 0,1042 kPa/m 1,015 m/s	-	-
220 kW	330 kW	440 kW	550 kW	660 kW	770 kW	880 kW	18925 kg/h	110/79,8 0,1134 kPa/m 1,064 m/s	-	-
230 kW	345 kW	460 kW	575 kW	690 kW	805 kW	920 kW	19785 kg/h	110/79,8 0,1229 kPa/m 1,112 m/s	-	-
240 kW	360 kW	480 kW	600 kW	720 kW	840 kW	960 kW	20640 kg/h	110/79,8 0,1327 kPa/m 1,160 m/s	-	-
250 kW	375 kW	500 kW	625 kW	750 kW	875 kW	1000 kW	21505 kg/h	110/79,8 0,1429 kPa/m 1,209 m/s	-	-
260 kW	390 kW	520 kW	650 kW	780 kW	910 kW	1040 kW	22366 kg/h	110/79,8 0,1534 kPa/m 1,257 m/s	-	-
270 kW	405 kW	540 kW	675 kW	810 kW	945 kW	1080 kW	23220 kg/h	110/79,8 0,1643 kPa/m 1,306 m/s	-	-

5.4 Heat loss tables

The heat loss figures in the following tables have been calculated using CFD (Computational Fluid Dynamics) simulation with the conditions and parameters given in EN 15632-1 and EN 13941-1.

For single pipes the tables show the heat loss of one pipe. To get the total heat loss add the flow and return heat losses.

Twin and Quattro pipe tables show the heat loss of complete pipe (flow and return/circulation).

Calculation conditions

Pipe installation, Single pipes	2-Pipe
Pipe distance, Single pipes (A)	0,1 m
Pipe installation, Twin and Quattro pipes	1-Pipe
Depth of cover (H)	0,8 m
Heat conductivity, soil λ_{soil}	1,0 W/m·K
Heat conductivity, VIP ($\lambda_{50, COP}$)	0,0042 W/(m·K)
Heat conductivity, PE-x foam (λ_{50})	0,0410 W/(m·K)
Heat conductivity, PE-x pipe	0,4000 W/(m·K)
Heat conductivity, PE jacket pipe	0,4000 W/(m·K)

Heat loss calculation symbols

- q = Heat loss [W/m]
- U = Heat loss coefficient [W/m·K]
- $\Delta\vartheta$ = Temperature difference between average operating temperature and ground [K]
- ϑ_{av} = Average operating temperature [°C]
- ϑ_f = Flow pipe temperature [°C]
- ϑ_r = Return pipe temperature [°C]
- ϑ_g = Ground temperature [°C]

Heat flow in 2-pipe installation

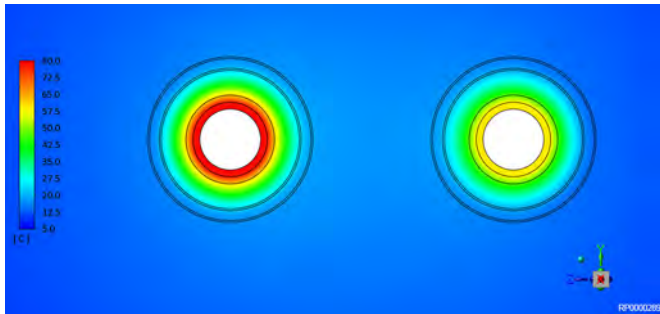

Heat flow in twin pipe installation

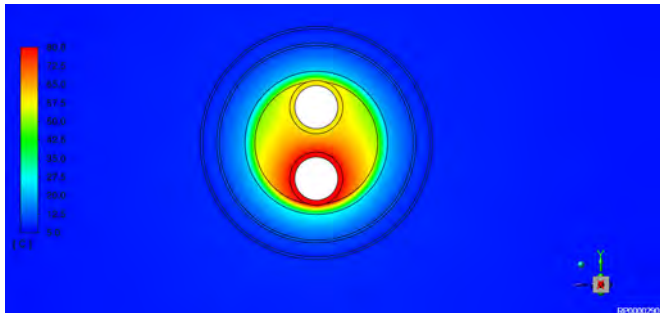

Heat loss calculation

$q = U \cdot \Delta\vartheta$ [W/m], where

$\Delta\vartheta = \vartheta_{av} - \vartheta_g$ [K]

$\vartheta_{av} = \frac{1}{2} \cdot (\vartheta_f + \vartheta_r)$ [°C]

For Ecoflex Quattro pipes ϑ_{av} is calculated as average of all four service pipes for heating and warm tap water.

Example heat loss table reading

Flow temperature: $\vartheta_f = 80$ °C

Return temperature: $\vartheta_r = 60$ °C

Ground temperature: $\vartheta_g = 10$ °C

$\vartheta_{av} = \frac{1}{2} \cdot (80 \text{ °C} + 60 \text{ °C}) = 70$ °C

$\Delta\vartheta = \vartheta_{av} - \vartheta_g = 70 \text{ °C} - 10 \text{ °C} = 60$ K

2 pipe installation – example Ecoflex VIP Thermo Single 63/140

Heat loss for one pipe:

$q = 8,3$ W/m (from the table)

Heat loss for flow and return:

$q = 2 \times 8,3$ W/m = 16,6 W/m

Twin pipe installation – example Ecoflex VIP Thermo Twin 63/200

Heat loss for flow and return:

$q = 12,7$ W/m (from the table)

Ecoflex VIP Thermo Single PN 6

Type	Heat loss q [W/m] for corresponding temperature difference $\Delta\vartheta$ [K]					
	30	40	50	60	70	80
40/140	3,0	3,9	4,9	5,9	6,9	7,9
50/140	3,5	4,6	5,8	6,9	8,1	9,2
63/140	4,1	5,5	6,9	8,3	9,7	11,1
75/140	4,9	6,5	8,1	9,8	11,4	13,0
90/175	5,0	6,6	8,3	10,0	11,6	13,3
110/175	6,3	8,4	10,5	12,5	14,6	16,7
125/200	6,4	8,6	10,7	12,9	15,0	17,2
140/200	7,6	10,1	12,7	15,2	17,7	20,3
160/250	7,4	9,9	12,3	14,8	17,3	19,8

Ecoflex VIP Thermo Twin PN 6

Type	Heat loss q [W/m] for corresponding temperature difference $\Delta\vartheta$ [K]					
	30	40	50	60	70	80
2x 25/140	3,7	4,9	6,1	7,3	8,5	9,8
2x 32/140	4,4	5,8	7,3	8,7	10,2	11,6
2x 40/175	4,6	6,1	7,7	9,2	10,7	12,3
2x 50/175	5,6	7,4	9,3	11,1	13,0	14,8
2x 63/200	6,4	8,5	10,6	12,7	14,8	16,9
2x 75/250	6,7	8,9	11,1	13,3	15,6	17,8

Ecoflex Thermo Single PN 6

Type	Heat loss q [W/m] for corresponding temperature difference $\Delta\theta$ [K]					
	30	40	50	60	70	80
25/140	4,2	5,6	7,0	8,4	9,8	11,2
32/140	4,9	6,5	8,1	9,7	11,4	13,0
40/175	4,8	6,5	8,1	9,7	11,3	12,9
50/175	5,6	7,5	9,4	11,3	13,2	15,0
63/175	6,8	9,0	11,3	13,6	15,8	18,1
75/200	7,0	9,3	11,6	14,0	16,3	18,6
90/200	8,4	11,2	13,9	16,7	19,5	22,3
110/200	10,7	14,3	17,8	21,4	24,9	28,5

Ecoflex Thermo Single PN 10

Type	Heat loss q [W/m] for corresponding temperature difference $\Delta\theta$ [K]					
	30	40	50	60	70	80
40/175	4,8	6,4	8,0	9,6	11,2	12,8
50/175	5,6	7,5	9,3	11,2	13,0	14,9
63/175	6,7	9,0	11,2	13,4	15,7	17,9
75/200	6,9	9,2	11,5	13,8	16,1	18,4
90/200	8,3	11,0	13,8	16,5	19,3	22,0
110/200	10,5	14,0	17,5	21,0	24,5	28,0

Ecoflex Thermo Twin PN 6

Type	Heat loss q [W/m] for corresponding temperature difference $\Delta\theta$ [K]					
	30	40	50	60	70	80
2x 25/175	5,8	7,7	9,7	11,6	13,5	15,5
2x 32/175	6,9	9,2	11,5	13,8	16,1	18,4
2x 40/175	8,6	11,4	14,3	17,1	20,0	22,9
2x 50/200	9,1	12,1	15,2	18,2	21,2	24,3
2x 63/200	12,8	17,0	21,3	25,6	29,8	34,1

Ecoflex Thermo Mini PN 6

Type	Heat loss q [W/m] for corresponding temperature difference $\Delta\theta$ [K]					
	30	40	50	60	70	80
25/68	6,9	9,2	11,4	13,7	16,0	18,3
32/68	8,8	11,7	14,7	17,6	20,6	23,5

Ecoflex Thermo Twin HP PN 6

Type	Heat loss q [W/m] for corresponding temperature difference $\Delta\theta$ [K]					
	30	40	50	60	70	80
2x 32-2x 32/140	10,4	13,9	17,3	20,8	24,3	27,7
2x 40-2x 32/175	11,3	15,0	18,8	22,5	26,3	30,1

Ecoflex Varia Single PN 6

Type	Heat loss q [W/m] for corresponding temperature difference $\Delta\theta$ [K]					
	30	40	50	60	70	80
25/90	5,2	6,9	8,6	10,3	12,1	13,8
32/90	6,2	8,3	10,3	12,4	14,5	16,5
40/140	5,7	7,6	9,5	11,3	13,2	15,1
50/140	6,8	9,0	11,3	13,6	15,8	18,1
63/140	8,5	11,4	14,2	17,0	19,9	22,7
75/175	8,0	10,7	13,4	16,0	18,7	21,4
90/175	9,9	13,2	16,5	19,8	23,1	26,4
110/175	13,3	17,7	22,2	26,6	31,0	35,5
125/200	13,0	17,3	21,7	26,0	30,3	34,6

Ecoflex Varia Twin PN 6

Type	Heat loss q [W/m] for corresponding temperature difference $\Delta\theta$ [K]					
	30	40	50	60	70	80
2x 25/140	7,1	9,4	11,8	14,2	16,5	18,9
2x 32/140	8,8	11,7	14,7	17,6	20,5	23,5
2x 40/140	11,9	15,9	19,9	23,9	27,8	31,8
2x 50/175	11,1	14,9	18,6	22,3	26,0	29,7

Ecoflex VIP Aqua Single PN 10

Type	Heat loss q [W/m] for corresponding temperature difference $\Delta\theta$ [K]					
	30	40	50	60	70	80
40/140	2,9	3,9	4,9	5,9	6,9	7,8
50/140	3,4	4,6	5,7	6,9	8,0	9,2
63/140	4,1	5,5	6,9	8,2	9,6	11,0
75/140	4,8	6,5	8,1	9,7	11,3	12,9
90/175	4,9	6,6	8,2	9,9	11,5	13,2
110/175	6,2	8,3	10,4	12,4	14,5	16,6

Ecoflex VIP Aqua Twin PN 10

Type	Heat loss q [W/m] for corresponding temperature difference $\Delta\theta$ [K]					
	30	40	50	60	70	80
25-20/140	3,5	4,7	5,9	7,1	8,3	9,5
32-20/140	3,7	5,0	6,2	7,5	8,7	10,0
40-25/140	4,4	5,9	7,4	8,9	10,3	11,8
50-32/175	4,7	6,3	7,9	9,5	11,0	12,6
63-40/200	5,1	6,8	8,5	10,3	12,0	13,7

Ecoflex Aqua Single PN 10

Type	Heat loss q [W/m] for corresponding temperature difference $\Delta\theta$ [K]					
	30	40	50	60	70	80
25/140	4,2	5,6	7,0	8,4	9,8	11,2
28/175	4,5	5,9	7,4	8,9	10,4	11,9
32/140	4,8	6,4	8,1	9,7	11,3	12,9
40/175	4,8	6,4	8,0	9,6	11,2	12,8
50/175	5,6	7,5	9,3	11,2	13,0	14,9
63/175	6,7	9,0	11,2	13,4	15,7	17,9

Ecoflex Aqua Twin PN 10

Type	Heat loss q [W/m] for corresponding temperature difference $\Delta\theta$ [K]					
	30	40	50	60	70	80
25-20/140	6,7	8,9	11,1	13,3	15,6	17,8
25-25/175	5,8	7,7	9,6	11,6	13,5	15,4
28-18/140	6,8	9,1	11,4	13,7	15,9	18,2
28-22/140	7,1	9,5	11,8	14,2	16,6	18,9
32-18/175	5,9	7,9	9,9	11,9	13,8	15,8
32-20/175	6,0	7,9	9,9	11,9	13,9	15,9
32-22/175	6,3	8,5	10,6	12,7	14,8	16,9
32-25/175	6,5	8,7	10,8	13,0	15,2	17,3
32-28/175	6,7	8,9	11,1	13,3	15,5	17,8
40-25/175	7,0	9,4	11,7	14,1	16,4	18,8
40-28/175	7,2	9,6	12,0	14,4	16,8	19,2
40-32/175	7,9	10,6	13,2	15,9	18,5	21,2
50-25/175	8,5	11,3	14,1	16,9	19,7	22,5
50-32/175	8,9	11,8	14,8	17,8	20,7	23,7
50-40/200	8,4	11,2	14,0	16,7	19,5	22,3
50-50/200	9,0	12,0	15,0	18,0	21,1	24,1

Ecoflex Quattro PN 6 + PN 10

Type	Heat loss q [W/m] for corresponding temperature difference $\Delta\theta$ [K]					
	30	40	50	60	70	80
2x 25-28-18/175	8,1	10,8	13,5	16,2	18,9	21,6
2x 25-25-20/175	8,0	10,6	13,3	16,0	18,6	21,3
2x 25-2x 25/175	8,2	10,9	13,6	16,4	19,1	21,8
2x 32-25-20/175	8,7	11,6	14,5	17,4	20,3	23,2
2x 32-2x 25/175	8,9	11,9	14,8	17,8	20,8	23,7
2x 32-28-18/175	8,8	11,8	14,7	17,7	20,6	23,5
2x 32-32-18/175	9,1	12,1	15,1	18,2	21,2	24,2
2x 32-32-20/175	9,1	12,2	15,2	18,3	21,3	24,4
2x 32-32-25/175	9,3	12,4	15,5	18,7	21,8	24,9
2x 32-2x 32/175	9,6	12,9	16,1	19,3	22,5	25,7
2x 40-32-18/200	9,2	12,3	15,3	18,4	21,5	24,6
2x 40-32-20/200	9,2	12,3	15,4	18,5	21,6	24,7
2x 40-40-25/200	9,8	13,1	16,4	19,7	23,0	26,2
2x 40-40-28/200	9,9	13,2	16,6	19,9	23,2	26,5

Ecoflex Quattro Midi PN 6 + PN 10

Type	Heat loss q [W/m] for corresponding temperature difference $\Delta\theta$ [K]					
	30	40	50	60	70	80
2x 25-25-20/140	8,5	11,3	14,1	16,9	19,8	22,6
2x 32-25-20/140	9,1	12,1	15,1	18,2	21,2	24,2
2x 40-32-25/175	9,2	12,3	15,3	18,4	21,5	24,6

5.5 Pressure loss for Ecoflex heating pipes, PN 6 (SDR 11)

Pressure loss at 50 °C water temperature, pipes 25 - 75 mm

Medium pipe	OD x s [mm]	25 x 2,3		32 x 2,9		40 x 3,7		50 x 4,6		63 x 5,8		75 x 6,8	
	ID [mm]	20,4		26,2		32,6		40,8		51,4		61,4	
l/h	l/s	kPa/m	m/s	kPa/m	m/s	kPa/m	m/s	kPa/m	m/s	kPa/m	m/s	kPa/m	m/s
180	0,05	0,018	0,153										
216	0,06	0,025	0,184										
252	0,07	0,033	0,214										
288	0,08	0,042	0,245										
324	0,09	0,051	0,275										
360	0,1	0,062	0,306	0,019	0,185								
720	0,2	0,214	0,612	0,065	0,371	0,023	0,240						
1080	0,3	0,444	0,918	0,134	0,556	0,047	0,359						
1440	0,4	0,745	1,224	0,224	0,742	0,079	0,479	0,027	0,306				
1800	0,5	1,114	1,530	0,335	0,927	0,117	0,599	0,040	0,382				
2160	0,6	1,548	1,836	0,465	1,113	0,163	0,719	0,056	0,459				
2520	0,7	2,044	2,142	0,614	1,298	0,215	0,839	0,073	0,535				
2880	0,8	2,601	2,448	0,782	1,484	0,274	0,958	0,093	0,612	0,031	0,386		
3240	0,9	3,217	2,754	0,967	1,669	0,338	1,078	0,115	0,688	0,038	0,434		
3600	1,0	3,891	3,059	1,169	1,855	0,409	1,198	0,139	0,765	0,046	0,482		
3960	1,1	4,623	3,365	1,389	2,040	0,486	1,318	0,165	0,841	0,055	0,530		
4320	1,2			1,625	2,226	0,568	1,438	0,193	0,918	0,064	0,578	0,027	0,405
5040	1,4			2,147	2,597	0,751	1,677	0,255	1,071	0,084	0,675	0,036	0,473
5760	1,6			2,733	2,968	0,956	1,917	0,325	1,224	0,107	0,771	0,046	0,540
6480	1,8			3,383	3,339	1,182	2,156	0,402	1,377	0,133	0,867	0,056	0,608
7200	2,0					1,431	2,396	0,486	1,530	0,160	0,964	0,068	0,675
7920	2,2					1,700	2,636	0,578	1,683	0,190	1,060	0,081	0,743
8640	2,4					1,990	2,875	0,676	1,836	0,223	1,157	0,095	0,811
9360	2,6					2,300	3,115	0,782	1,989	0,257	1,253	0,110	0,878
10080	2,8					2,631	3,355	0,894	2,142	0,294	1,349	0,125	0,946
10800	3,0					2,981	3,594	1,013	2,295	0,334	1,446	0,142	1,013
12600	3,5							1,339	2,677	0,441	1,687	0,187	1,182
14400	4,0							1,706	3,059	0,561	1,928	0,239	1,351
16200	4,5							2,112	3,442	0,695	2,169	0,295	1,520
18000	5,0									0,841	2,410	0,358	1,689
19800	5,5									1,000	2,651	0,425	1,858
21600	6,0									1,171	2,892	0,498	2,026
23400	6,5									1,354	3,133	0,575	2,195
25200	7,0									1,549	3,374	0,658	2,364
27000	7,5											0,746	2,533
28800	8,0											0,839	2,702
30600	8,5											0,936	2,871
32400	9,0											1,039	3,040
34200	9,5											1,146	3,208
36000	10,0											1,258	3,377

Pressure loss at 50 °C water temperature, pipes 90 - 160 mm

Medium pipe	OD x s [mm]	90 x 8,2		110 x 10		125 x 11,4		140 x 12,7		160 x 14,6	
	ID [mm]	73,6		90,0		102,2		114,6		130,8	
l/h	l/s	kPa/m	m/s	kPa/m	m/s	kPa/m	m/s	kPa/m	m/s	kPa/m	m/s
6480	1,8	0,024	0,423								
7200	2,0	0,029	0,470								
7920	2,2	0,034	0,517								
8640	2,4	0,040	0,564								
9360	2,6	0,046	0,611								
10080	2,8	0,052	0,658								
10800	3,0	0,059	0,705	0,023	0,472						
12600	3,5	0,078	0,823	0,030	0,550						
14400	4,0	0,100	0,940	0,038	0,629	0,021	0,488				
16200	4,5	0,124	1,058	0,047	0,707	0,025	0,549				
18000	5,0	0,150	1,175	0,057	0,786	0,031	0,610	0,019	0,485	0,009	0,372
19800	5,5	0,178	1,293	0,068	0,865	0,037	0,670	0,021	0,533	0,010	0,409
21600	6,0	0,208	1,410	0,079	0,943	0,043	0,731	0,024	0,582	0,012	0,447
23400	6,5	0,240	1,528	0,091	1,022	0,050	0,792	0,029	0,630	0,014	0,484
25200	7,0	0,275	1,645	0,104	1,100	0,057	0,853	0,033	0,679	0,017	0,521
27000	7,5	0,312	1,763	0,118	1,179	0,064	0,914	0,038	0,727	0,018	0,558
28800	8,0	0,350	1,880	0,133	1,258	0,072	0,975	0,044	0,776	0,020	0,595
30600	8,5	0,391	1,998	0,149	1,336	0,081	1,036	0,047	0,824	0,022	0,633
32400	9,0	0,434	2,115	0,165	1,415	0,089	1,097	0,050	0,873	0,026	0,670
34200	9,5	0,479	2,233	0,182	1,493	0,099	1,158	0,056	0,921	0,028	0,707
36000	10,0	0,525	2,350	0,199	1,572	0,108	1,219	0,060	0,969	0,030	0,744
37800	10,5	0,574	2,468	0,218	1,650	0,118	1,280	0,069	1,018	0,034	0,781
39600	11,0	0,625	2,586	0,237	1,729	0,129	1,341	0,077	1,066	0,038	0,819
43200	12,0	0,732	2,821	0,278	1,886	0,151	1,463	0,088	1,163	0,043	0,893
46800	13,0	0,847	3,056	0,321	2,043	0,174	1,585	0,101	1,260	0,053	0,967
50400	14,0	0,969	3,291	0,367	2,201	0,199	1,707	0,116	1,357	0,056	1,042
54000	15,0	1,098	3,526	0,417	2,358	0,226	1,829	0,135	1,454	0,062	1,116
57600	16,0			0,468	2,515	0,254	1,950	0,150	1,551	0,071	1,191
61200	17,0			0,523	2,672	0,283	2,072	0,164	1,648	0,080	1,265
64800	18,0			0,580	2,829	0,315	2,194	0,178	1,745	0,093	1,340
68400	19,0			0,640	2,987	0,347	2,316	0,196	1,842	0,098	1,414
72000	20,0			0,703	3,144	0,381	2,438	0,223	1,939	0,109	1,488
79200	22,0			0,837	3,458	0,453	2,682	0,268	2,133	0,126	1,637
86400	24,0					0,531	2,926	0,327	2,327	0,152	1,786
93600	26,0					0,614	3,169	0,376	2,521	0,187	1,935
100800	28,0					0,703	3,413	0,418	2,715	0,205	2,084
108000	30,0							0,509	2,908	0,232	2,233
115200	32,0							0,535	3,102	0,254	2,381
122400	34,0							0,625	3,296	0,285	2,530
129600	36,0							0,714	3,490	0,312	2,679
136800	38,0									0,361	2,828
144000	40,0									0,406	2,977
162000	45,0									0,517	3,349

Pressure loss correction factors for other water temperatures

°C	10	15	20	25	30	35	40	45	50
Factor	1,217	1,183	1,150	1,117	1,100	1,067	1,050	1,017	1,000

°C	55	60	65	70	75	80	85	90	95
Factor	0,983	0,967	0,952	0,938	0,933	0,918	0,904	0,890	0,873

Pressure loss diagram at water temperature 70 °C

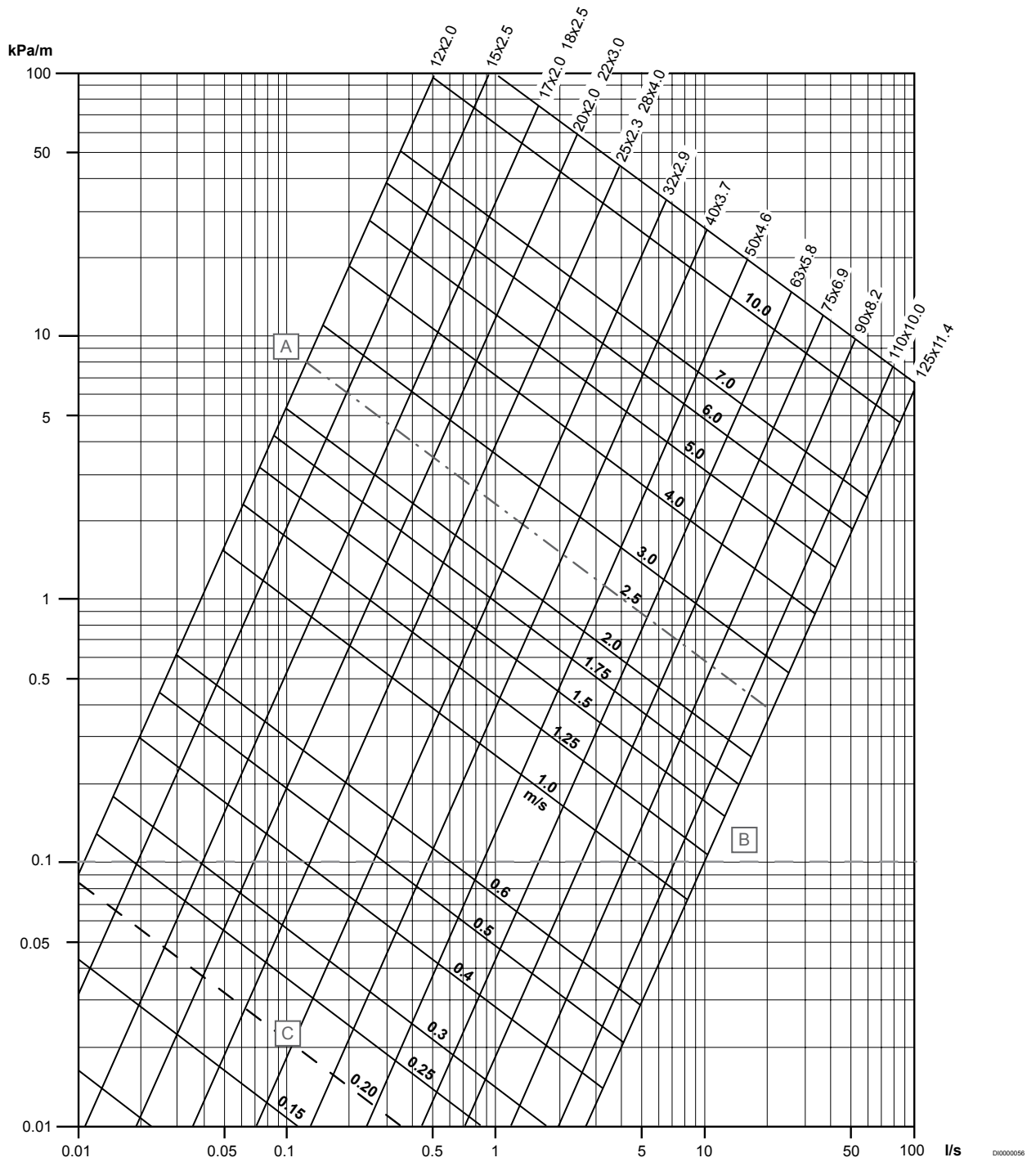

The nomogram is calculated at a water temperature of +70 °C.

Item	Description
A	Recommended max. water speed with continuous flow versus high pressure drop and sound level (2,5 m/s)
B	Guideline for sizing (pressure drop 0,1 kPa)
C	Minimum water speed (0,20 m/s)

Temp. °C	90	80	70	60	50	40	30	20	10
Factor	0,95	0,98	1,00	1,02	1,05	1,10	1,14	1,20	1,25

Roughness factor 0,0005

5.6 Pressure loss for Ecoflex warm tap water pipes, PN 10 (SDR 7,4)

Pressure loss at 50 °C water temperature, pipes 20 - 50

Medium pipe	OD x s [mm]	20 x 2,8		25 x 3,5		32 x 4,4		40 x 5,5		50 x 6,9	
	ID [mm]	14,4		18		23,2		29		36,2	
l/h	l/s	kPa/m	m/s	kPa/m	m/s	kPa/m	m/s	kPa/m	m/s	kPa/m	m/s
36	0,01	0,005	0,061	-	-	-	-	-	-	-	-
72	0,02	0,018	0,123	-	-	-	-	-	-	-	-
108	0,03	0,038	0,184	-	-	-	-	-	-	-	-
144	0,04	0,064	0,246	-	-	-	-	-	-	-	-
180	0,05	0,095	0,307	0,033	0,196	-	-	-	-	-	-
216	0,06	0,132	0,368	0,045	0,236	-	-	-	-	-	-
252	0,07	0,173	0,430	0,060	0,275	-	-	-	-	-	-
288	0,08	0,220	0,491	0,076	0,314	-	-	-	-	-	-
324	0,09	0,272	0,553	0,093	0,354	0,028	0,213	-	-	-	-
360	0,1	0,328	0,614	0,113	0,393	0,033	0,237	-	-	-	-
720	0,2	1,140	1,228	0,391	0,786	0,116	0,473	0,040	0,303	-	-
1080	0,3	2,364	1,848	0,810	1,179	0,240	0,710	0,082	0,454	0,028	0,291
1440	0,4	3,969	2,456	1,360	1,572	0,402	0,946	0,138	0,606	0,048	0,389
1800	0,5	5,936	3,070	2,032	1,965	0,601	1,183	0,206	0,757	0,071	0,486
2160	0,6	8,249	3,684	2,823	2,358	0,834	1,419	0,286	0,908	0,099	0,583
2520	0,7			3,729	2,751	1,102	1,656	0,377	1,060	0,130	0,680
2880	0,8			4,746	3,144	1,402	1,892	0,480	1,211	0,165	0,777
3240	0,9			5,871	3,537	1,734	2,129	0,593	1,363	0,205	0,874
3600	1,0					2,097	2,366	0,718	1,514	0,247	0,972
3960	1,1					2,491	2,602	0,852	1,665	0,294	1,069
4320	1,2					2,915	2,839	0,997	1,817	0,344	1,166
5040	1,4					3,853	3,312	1,318	2,120	0,454	1,360
5760	1,6							1,677	2,422	0,578	1,555
6480	1,8							2,076	2,725	0,715	1,749
7200	2,0							2,512	3,028	0,865	1,943
7920	2,2							2,985	3,331	1,027	2,138
8640	2,4							3,494	3,634	1,202	2,332
9360	2,6									1,390	2,526
10080	2,8									1,589	2,721
10800	3,0									1,801	2,915
12600	3,5									2,382	3,401

Pressure loss at 50 °C water temperature, pipes 63 - 110

Medium pipe	OD x s [mm]	63 x 8,7		75 x 10,3		90 x 12,3		110 x 15,1	
	ID [mm]	45,6		54,4		65,4		79,8	
l/h	l/s	kPa/m	m/s	kPa/m	m/s	kPa/m	m/s	kPa/m	m/s
1800	0,5	0,023	0,306						
2160	0,6	0,033	0,367						
2520	0,7	0,043	0,429	0,018	0,301				
2880	0,8	0,055	0,490	0,023	0,344				
3240	0,9	0,068	0,551	0,029	0,387				
3600	1,0	0,082	0,612	0,035	0,430				
3960	1,1	0,097	0,674	0,042	0,473				
4320	1,2	0,113	0,735	0,049	0,516				
5040	1,4	0,150	0,857	0,064	0,602				
5760	1,6	0,190	0,980	0,082	0,688	0,034	0,476		
6480	1,8	0,236	1,102	0,101	0,774	0,042	0,536		
7200	2,0	0,285	1,225	0,122	0,860	0,050	0,595		
7920	2,2	0,339	1,347	0,145	0,947	0,060	0,655		
8640	2,4	0,396	1,470	0,170	1,033	0,070	0,714		
9360	2,6	0,458	1,592	0,196	1,119	0,081	0,774	0,031	0,520
10080	2,8	0,524	1,715	0,224	1,205	0,092	0,834	0,036	0,560
10800	3,0	0,593	1,837	0,254	1,291	0,105	0,893	0,040	0,600
12600	3,5	0,784	2,143	0,336	1,506	0,138	1,042	0,053	0,700
14400	4,0	0,999	2,449	0,427	1,721	0,176	1,191	0,068	0,800
16200	4,5	1,237	2,755	0,529	1,936	0,218	1,340	0,084	0,900
18000	5,0	1,497	3,062	0,640	2,151	0,264	1,488	0,101	1,000
19800	5,5	1,780	3,368	0,761	2,366	0,314	1,637	0,120	1,100
21600	6,0	2,084	3,674	0,891	2,581	0,367	1,786	0,141	1,200
23400	6,5			1,030	2,797	0,425	1,935	0,163	1,300
25200	7,0			1,179	3,012	0,486	2,084	0,186	1,400
27000	7,5			1,336	3,227	0,550	2,233	0,211	1,500
28800	8,0			1,502	3,442	0,619	2,381	0,237	1,600
30600	8,5			1,677	3,657	0,691	2,530	0,265	1,700
32400	9,0					0,766	2,679	0,294	1,799
34200	9,5					0,846	2,828	0,324	1,899
36000	10,0					0,928	2,977	0,356	1,999
37800	10,5					1,014	3,126	0,389	2,099
39600	11,0					1,104	3,275	0,423	2,199
43200	12,0					1,293	3,572	0,496	2,399
46800	13,0							0,573	2,599
50400	14,0							0,656	2,799
54000	15,0							0,744	2,999
57600	16,0							0,836	3,199
61200	17,0							0,934	3,399

Pressure loss correction factors for other water temperatures

°C	10	15	20	25	30	35	40	45	50
Factor	1,208	1,174	1,144	1,115	1,087	1,060	1,039	1,019	1,000

°C	55	60	65	70	75	80	85	90	95
Factor	0,982	0,965	0,954	0,943	0,928	0,923	0,907	0,896	0,878

Pressure loss diagram at water temperature 70 °C

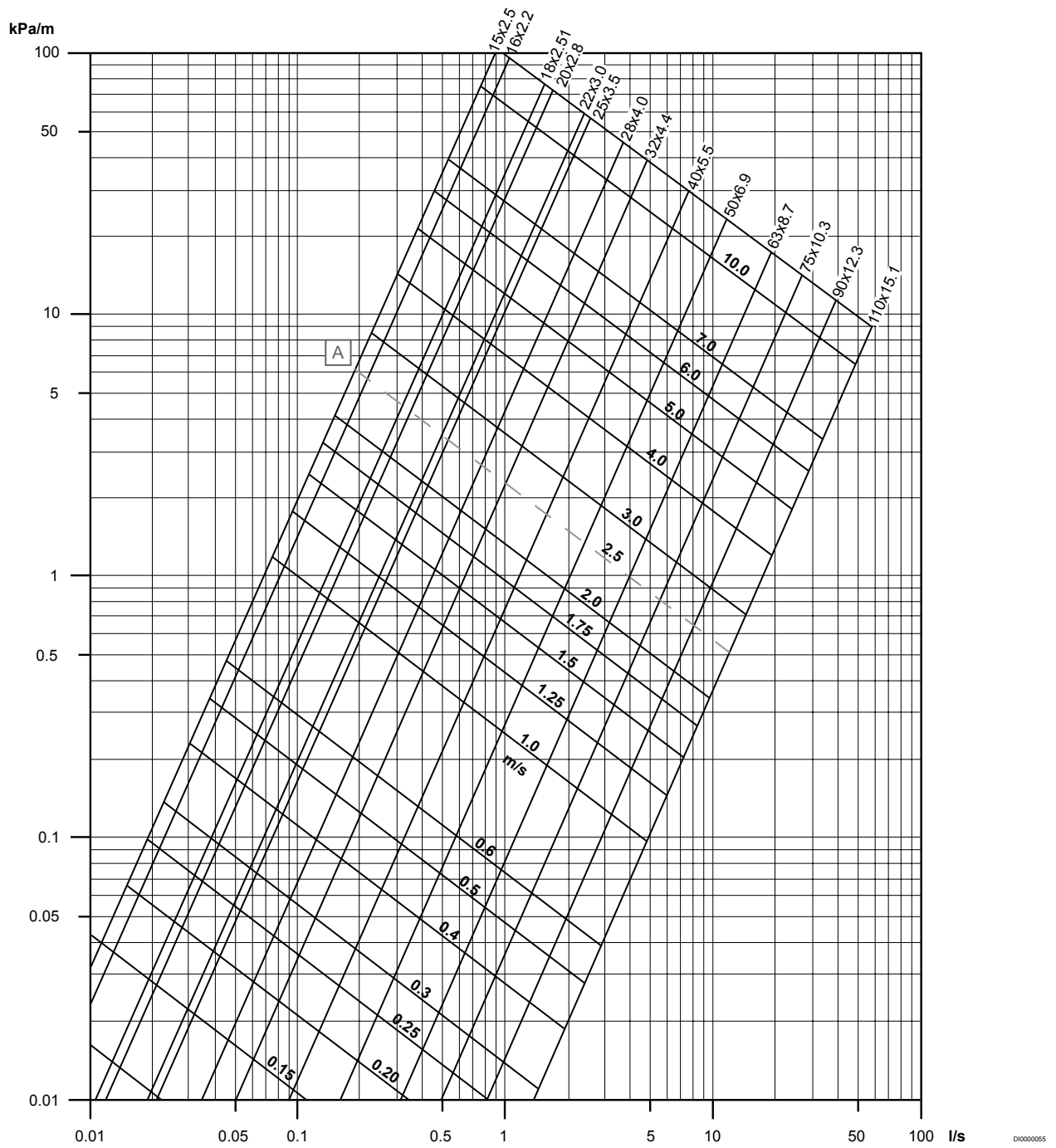

The nomogram is calculated at a water temperature of +70 °C.

Item	Description
A	Recommended max. water speed with continuous flow versus high pressure drops and sound levels (2,5 m/s)

Temp. °C	90	80	70	60	50	40	30	20	10
Factor	0,95	0,98	1,00	1,02	1,05	1,10	1,14	1,20	1,25

Roughness factor 0,0005

5.7 Pressure loss for Ecoflex Supra, Supra PLUS and Supra Standard pipes PN 16 (SDR 11)

Pressure loss at 20 °C water temperature, pipes 25 - 50 mm

Medium pipe	OD x s [mm]	25 x 2,3		32 x 2,9		40 x 3,7		50 x 4,6	
	ID [mm]	20,4		26,2		32,6		40,8	
l/h	l/s	kPa/m	m/s	kPa/m	m/s	kPa/m	m/s	kPa/m	m/s
90	0,025	0,0086	0,076						
113	0,032	0,0127	0,096	0,0041	0,059				
144	0,040	0,0189	0,122	0,0061	0,075				
180	0,050	0,0275	0,153	0,0088	0,094	0,0031	0,060		
227	0,063	0,0407	0,193	0,0130	0,119	0,0045	0,075		
288	0,080	0,0611	0,245	0,0195	0,151	0,0067	0,096	0,0024	0,061
360	0,100	0,0895	0,306	0,0285	0,188	0,0098	0,120	0,0034	0,076
450	0,125	0,1315	0,382	0,0417	0,235	0,0144	0,150	0,0050	0,096
576	0,160	0,2016	0,490	0,0638	0,301	0,0219	0,192	0,0076	0,122
720	0,200	0,2974	0,612	0,0939	0,377	0,0321	0,240	0,0111	0,153
900	0,250	0,4394	0,765	0,1384	0,471	0,0473	0,300	0,0163	0,191
1134	0,315	0,6599	0,964	0,2072	0,593	0,0706	0,377	0,0244	0,241
1440	0,400	1,0068	1,224	0,3152	0,753	0,1071	0,479	0,0369	0,306
1800	0,500	1,4972	1,530	0,4672	0,942	0,1585	0,599	0,0544	0,382
2268	0,630	2,2631	1,927	0,7039	1,187	0,2381	0,755	0,0816	0,482
2880	0,800	3,4774	2,448	1,0776	1,507	0,3634	0,958	0,1242	0,612
3600	1,000	5,2062	3,059	1,6072	1,883	0,5405	1,198	0,1842	0,765
4500	1,250			2,4022	2,354	0,8053	1,498	0,2738	0,956
5760	1,600			3,7567	3,014	1,2547	1,917	0,4253	1,224
7200	2,000					1,8774	2,396	0,6345	1,530
9000	2,500					2,8148	2,995	0,9483	1,912
11340	3,150							1,4406	2,409
14400	4,000							2,2247	3,059

Pressure loss at 20 °C water temperature, pipes 63 - 110 mm

Medium pipe	OD x s [mm]	63 x 5,8		75 x 6,8		90 x 8,2		110 x 10,0	
		ID [mm]	51,4	61,4	73,6	90,0			
l/h	l/s	kPa/m	m/s	kPa/m	m/s	kPa/m	m/s	kPa/m	m/s
450	0,125	0,0017	0,060						
576	0,160	0,0026	0,077	0,0011	0,054				
720	0,200	0,0037	0,096	0,0016	0,068				
900	0,250	0,0055	0,120	0,0024	0,085	0,0010	0,059		
1134	0,315	0,0082	0,152	0,0036	0,107	0,0015	0,074		
1440	0,400	0,0123	0,193	0,0054	0,136	0,0023	0,094	0,0009	0,063
1800	0,500	0,0182	0,241	0,0079	0,170	0,0033	0,118	0,0013	0,079
2268	0,630	0,0272	0,304	0,0119	0,214	0,0049	0,148	0,0019	0,099
2880	0,800	0,0413	0,386	0,0180	0,272	0,0075	0,188	0,0029	0,126
3600	1,000	0,0611	0,482	0,0266	0,340	0,0111	0,235	0,0043	0,157
4500	1,250	0,0906	0,602	0,0394	0,425	0,0163	0,294	0,0063	0,196
5760	1,600	0,1403	0,771	0,0609	0,544	0,0252	0,376	0,0097	0,252
7200	2,000	0,2088	0,964	0,0904	0,680	0,0374	0,470	0,0143	0,314
9000	2,500	0,3112	1,205	0,1345	0,850	0,0555	0,588	0,0212	0,393
11340	3,150	0,4714	1,518	0,2033	1,071	0,0838	0,740	0,0320	0,495
14400	4,000	0,7254	1,928	0,3123	1,360	0,1285	0,940	0,0489	0,629
18000	5,000	1,0873	2,410	0,4670	1,700	0,1917	1,175	0,0729	0,786
22680	6,300	1,6567	3,036	0,7098	2,142	0,2908	1,481	0,1103	0,990
28800	8,000			1,0965	2,720	0,4480	1,880	0,1695	1,258
36000	10,000			1,6493	3,399	0,6722	2,350	0,2537	1,572
45000	12,500					1,0104	2,938	0,3924	1,965
57600	16,000							0,5966	2,515
72000	20,000							0,8977	3,144

Pressure loss for potable water/cooling water pipes at 20 °C water temperature

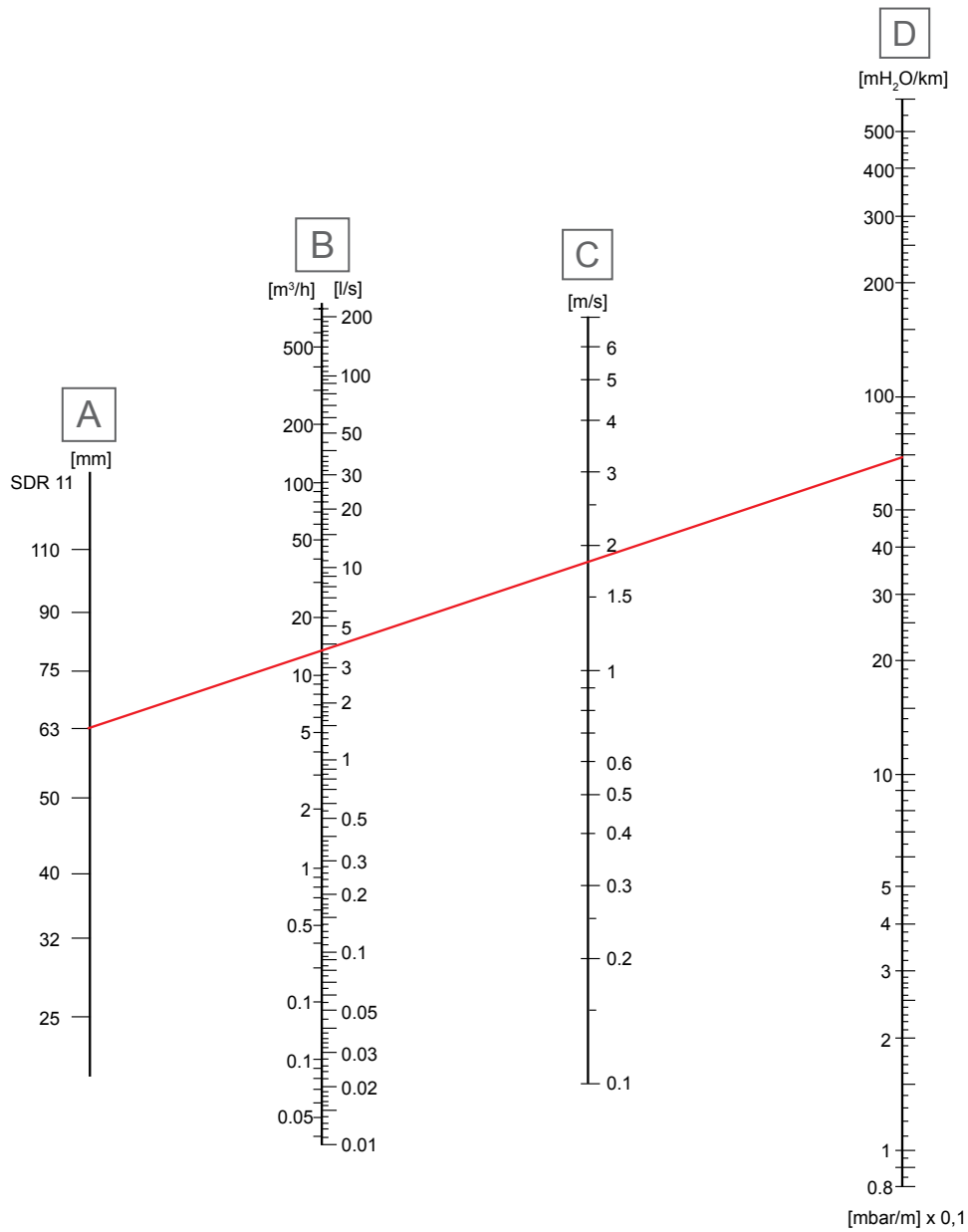

D0000142

Item	Description
A	Pipe diameter do1 [mm]
B	Volume flow rate \dot{V} [m³/h] / [l/s]
C	Flow speed v [m/s]
D	Pressure loss Δp [mH ₂ O/km] / [mbar/m] x 0,1

Example

General data:

$\dot{V} = 3,8$ l/s
 $v = 1,8$ m/s
 pipe length = 120 m

Outcome:

do1 = 63 mm
 $\Delta p = 68$ mH₂O/1000 x 120 m
 8,2 mH₂O (0,82 bar)

5.8 Thermal losses for Uponor Ecoflex Supra pipes

Supra PLUS

The table shows the Uponor Ecoflex Supra PLUS element thermal losses in different ambient temperatures. The temperature of the pipe contents has been assumed to be +2 °C. When thermal loss is less than 10 W/m, the cable output is enough to secure operation. If thermal loss is more than 10 W/m then choose another pipe size where the thermal loss is below 10 W/m.

Thermal losses for Supra PLUS

Temp. outside the pipe °C	Pipe dimensions (do1/do [mm]) and thermal losses [W/m]										
	25/68	32/68	32/140	40/90	40/140	50/90	50/140	63/140	75/175	90/200	110/200
-1	1	1	0	1	1	1	1	1	1	1	1
-2	1	1	1	1	1	2	1	1	1	1	2
-3	1	2	1	1	1	2	1	1	1	1	2
-4	2	2	1	2	1	2	1	2	2	2	2
-5	2	2	1	2	1	3	2	2	2	2	3
-6	2	3	1	2	1	3	2	2	2	2	3
-7	2	3	1	3	2	4	2	3	3	3	3
-8	3	4	2	3	2	4	2	3	3	3	4
-9	3	4	2	3	2	4	2	3	3	3	4
-10	3	4	2	3	2	5	3	3	3	3	5
-12	4	5	2	4	3	5	3	4	4	4	5
-14	4	6	2	5	3	6	4	5	5	5	6
-16	5	6	3	5	3	7	4	5	5	5	7
-18	5	7	3	6	4	8	4	6	5	6	8
-20	6	8	3	6	4	9	5	6	6	6	8
-22	6	8	4	7	4	9	5	7	6	7	9
-24	7	9	4	7	5	10	6	7	7	7	10
-26	7	10	4	8	5	11	6	8	7	8	11
-28	8	11	5	9	5	12	7	9	8	9	11
-30	8	11	5	9	6	13	7	9	9	9	12
-32	9	12	5	10	6	13	8	10	9	10	13
-34	9	13	6	10	7	14	8	10	10	10	14
-36	10	13	6	11	7	15	8	11	10	11	14
-38	10	14	6	11	7	16	9	11	11	11	15
-40	11	15	7	12	8	16	9	12	11	12	16
-42	11	16	7	13	8	17	10	13	12	13	17
-44	12	16	7	13	8	18	10	14	12	13	17
-46	12	17	7	14	9	19	11	13	13	14	18
-48	13	18	8	14	9	20	11	14	13	14	19
-50	13	18	8	15	10	20	12	15	14	15	20

Supra Standard

The medium pipe is dimensioned according to normal pipe dimensions. Prevailing conditions must be taken into account when selecting the correct product, for example for ground installations, the temperature of the ground frost, which is approximately -10 °C at the lowest. When installing on pipe bridges, the outdoor temperature and wind chill cause significantly more demanding conditions.

The adjacent chart shows the Supra Standard thermal losses at various outdoor temperatures. The inside temperature of the pipe has been assumed to be 2 °C. Read the prevailing outdoor temperature on the first column and select the dimensions of the product on the top row. The chart shows the W/m value required for the pipe to remain unfrozen. Find a suitable connection option in the power curve with the voltage being 230 V or 400 V.

Example:

A pipeline with a total length of 120 m and dimensions 32/90 is installed on a pipe bridge outside in a location susceptible to wind chill, where the dimensioning temperature must be -50 °C. The required power is then 14 W/m. Connection voltage is selected at 230V and cable 2 x 0,48 W/m (yellow cable). By connecting 2 x 0,48 W/m in parallel + Cu-return achieves a power of 15 W/m.

Thermal losses for Supra Standard

Temp. outside the pipe °C	Pipe dimensions (do1/do [mm]) and thermal losses [W/m]								
	32/68	40/90	40/140	50/90	50/140	63/140	75/175	90/200	110/200
-1	1	1	1	2	1	1	1	1	1
-2	2	1	1	2	1	2	1	1	2
-3	2	2	1	3	1	2	2	2	2
-4	2	2	1	3	2	2	2	2	3
-5	3	2	2	4	2	3	3	2	3
-6	3	3	2	4	2	3	3	3	4
-7	4	3	2	5	3	4	3	3	4
-8	4	4	2	5	3	4	4	3	5
-9	5	4	3	6	3	4	4	4	5
-10	5	4	3	6	3	5	4	4	6
-12	6	5	3	7	4	6	5	5	7
-14	7	6	4	8	5	6	6	6	8
-16	7	6	4	9	5	7	7	6	9
-18	8	7	5	10	6	8	7	7	10
-20	9	8	5	11	6	9	8	8	11
-22	10	8	5	13	7	10	9	8	12
-24	11	9	6	14	8	10	9	9	13
-26	12	10	6	15	8	11	10	10	14
-28	12	11	7	16	9	12	11	10	15
-30	13	11	7	17	9	13	12	11	16
-32	14	12	8	18	10	14	12	12	17
-34	15	13	8	19	10	14	13	13	18
-36	16	13	9	20	11	15	14	13	19
-38	17	14	9	21	12	16	14	14	20
-40	17	15	10	22	12	17	15	15	21
-42	18	15	10	23	13	18	16	15	22
-44	19	16	10	24	13	19	17	16	23
-46	20	17	11	25	14	19	17	17	24
-48	21	18	11	26	14	20	18	17	25
-50	21	18	12	27	15	21	19	18	26

6 Installation and operation

6.1 Average installation times



The time required to lay these pipe systems depends on local conditions. The following table contains average installation times. Obstacles, underpasses, weather conditions, fitting times and other aspects have not been taken into account. The use of aids such as excavators or cable winches has also not been included in the calculation.

Ecoflex Thermo

Pipe type	25 m, fitters/min.	50 m, fitters/min.	100 m, fitters/min.
Single			
25	2 / 15	2 / 30	3 / 40
32	2 / 15	2 / 30	3 / 40
40	2 / 20	2 / 40	3 / 60
50	2 / 20	2 / 40	3 / 60
63	3 / 20	3 / 40	4 / 60
75	3 / 25	3 / 50	4 / 75
90	3 / 30	4 / 60	5 / 90
110	3 / 30	4 / 60	5 / 90
125	4 / 30	5 / 60	6 / 90
Twin			
25	2 / 20	2 / 40	3 / 60
32	2 / 20	2 / 40	3 / 60
40	2 / 30	3 / 40	4 / 60
50	3 / 25	3 / 50	5 / 90
63	3 / 30	4 / 60	5 / 90
75	3 / 40	4 / 70	5 / 100

Ecoflex Quattro

Pipe type	25 m, fitters/min.	50 m, fitters/min.	100 m, fitters/min.
25	2 / 20	2 / 40	3 / 60
32	2 / 30	3 / 40	4 / 60
40	3 / 25	3 / 50	4 / 80

Joining equipment and accessories

Item	Fitters / min
Ecoflex Rubber end caps	1 / 5
Wipex Coupling	1 / 15
Wipex straight joint	2 / 30
Wipex tee (complete)	2 / 40
Ecoflex Straight insulation set	1 / 35
Ecoflex T-insulation set	1 / 45
Ecoflex Elbow insulation set	1 / 35
Ecoflex H-insulation set	2 / 50
Ecoflex Chamber incl. 6 x connections to the jacket pipe	2 / 50
Ecoflex Wall sleeve set NPW (non pressure waterproof)	1 / 30
Ecoflex Wall seal PWP (pressure waterproof)	1 / 30

Number of fitters/group and minutes per item (e.g. 2 / 15 = 2 fitters require 15 minutes per item)

Calculation examples



Note

The assembly times mentioned in this section are group minutes for the corresponding number of fitters (not including excavation work).



Note

The figures are only guidance for calculation.

Example 1

- Installation of 2 x 25 m Uponor Ecoflex Thermo Single 63 mm
- 3 fitters with no additional help

Installation time: 2 x 20 minutes

Example 2

- Installation of a rubber end cap, a Wipex coupling and a wall sleeve set NPW
- 1 fitter with no additional help
- Guide figure for rubber end cap 1/5, Wipex coupling 1/15, wall sleeve set NPW 1/30

Installation time: 1 x 50 minutes

6.2 Installation of pipes, general instructions



Note

Installation must be performed by a qualified person in accordance with local standards and regulations.

The installation process varies from country to country. Always follow the local standards and regulations whenever the Uponor systems should be installed.

As a guidance, always read and follow the instructions given in respective Uponor installation manual.

Installation manual

Note

Installations of the Uponor systems are described in detail in respective installation manual. Visit the Uponor download centre for more information.



www.uponor.com/services/download-centre

Following installation manuals are applicable for Uponor Ecoflex:

- Uponor Ecoflex pipe handling INT
- Uponor Ecoflex insulation set INT
- Uponor Ecoflex rubber end cap INT
- Uponor Ecoflex chamber INT

Storing, lifting and handling

Note

When lifting pipe coils, use at least a 50 mm diameter nylon or textile loop. If a fork truck or other similar lifting equipment is used, the forks must be rounded or padded. Due to the flexibility and weight of the coils, the diameter of the coils can vary by up to 30 cm.

Note

Plastic materials must never be brought into contact with aggressive substances such as motor fuel, solvents, timber preservative or similar.

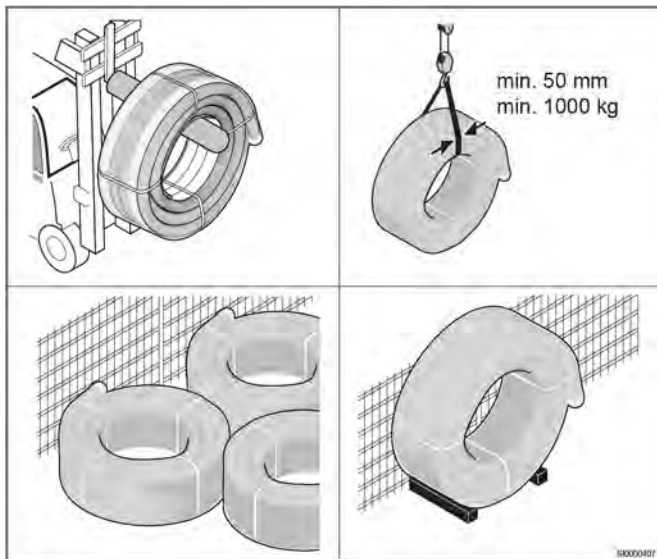

Do not drag the coil across rough surfaces. Ensure that the coil is not squashed and that the pipe is not dented when bent during storage. Store all coils in a horizontal position. Pipe coils and chambers can be stored outside, other components of the system should be stored indoors.

When unloading, do not drop the coils. Do not transport a pipe coil by pulling it. Use belts for lifting the coil.

Always during transportation and storage protect the ends of the pipes against sunlight, water or mud entering and other mechanical damage, including soiling during transportation. Protect the pipe coil from sharp objects during transportation and storage.

Uncoiling

Warning!

The pipe ends could whiplash when the textile tapes are opened. Make sure the coils are always secured with two to three tapes.

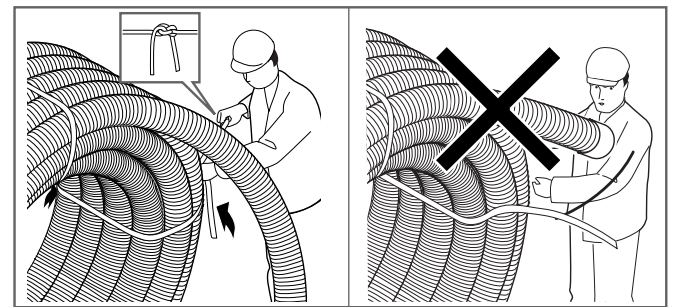

When embedding pipe sections, a sufficiently free pipe length of 3 to 5 metres must be provided for installing the connecting systems. Where there is a change of material from steel to plastic medium pipe, stress may be transferred from the steel to the plastic pipe during temperature changes. In this case, shear forces particularly are to be avoided; if necessary, provide fixed points around the ends of the steel medium pipe.

If installing in extremely low temperatures (increased pipe rigidity), the pipes should be stored in a heated hall or carry out the installation beneath a heated shelter directly at the trench.

Store the delivered coil for as long as possible in its protective packaging until installation! Then uncoil the pipe directly into or beside the trench.

Never pull the pipe across the ground as pointed objects could cause damage. Should the jacket pipe become damaged, it can be repaired using a shrinkable sleeve.

Prior to installation or processing, all pipeline parts and system accessories must be visually inspected for any damage that might negatively impact its function. Damaged parts must be discarded!

If the pipeline is to be installed horizontally in the open, support points (for example, using sand) must be provided to prevent the pipe from slipping later. If the ground is uneven, these supports must be provided every 25 metres.

Uncoiling the pipes from the inside

Note

Do not remove the plastic wrapper. Start unwinding the coil from the inside.

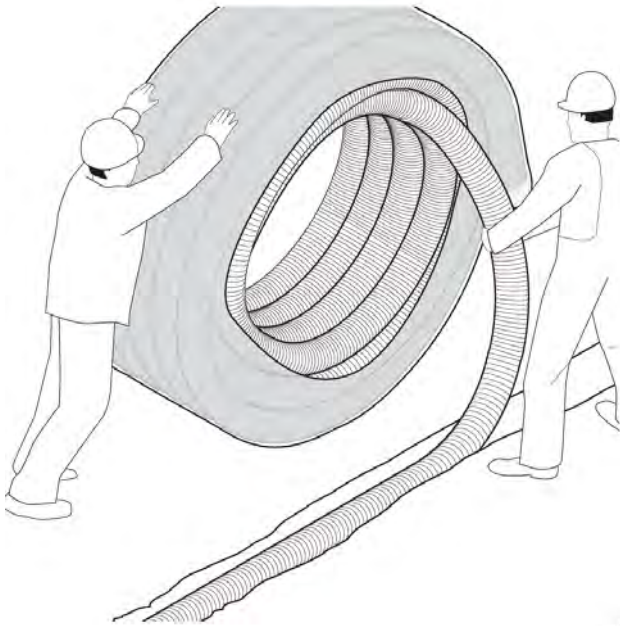

Uncoiling the pipes from the inside (recommended for jacket pipe diameters 68 – 175 mm or coiled lengths up to 50 m).

Do not remove exterior packaging! Cut the nylon securing tapes in the coil. Take out the inner pipe end from the coil (do not remove the end cap until the pipe is connected!). Fix the pipe ends in place (e.g. by weighing them down, for example by placing sand on top of them). Roll out the pipe, coil by coil.

Uncoiling the pipe from the outside

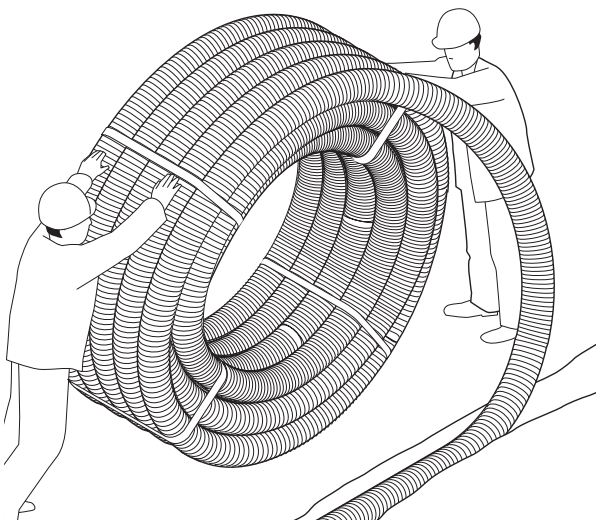

Uncoiling the pipe from the outside (recommended for jacket pipe diameters 68 – 250 mm or coiled lengths in excess of 50 m).

Remove the packaging foil (used in case of full coils). Open the first nylon tape at the outside pipe end, loosen the pipe end from the coil and fix the coil once more with the nylon tape. Warning – when opening the first nylon tape, the pipe end is under tension and can whiplash! Fix the loose pipe end in place (e.g. by weighing it down, for example by placing sand on top of it) and roll out as far as the next nylon tape. Repeat this process until the coil is completely unrolled.

Minimum allowed bending radius



Caution!

The medium pipe can kink or be damaged if the bending radius is smaller than the specified minimum.

Thanks to their structure and to the materials used, the Ecoflex pre-insulated pipe systems are extraordinarily flexible.

The smallest permitted bending radius (see tables in Chapter 2) must be taken into account when the pipes are laid.

Installation in cold temperatures

The installation is not recommended to be carried out in temperatures below -15 °C.

In cold weather, installation is easier if the pipes are already warm, for example from having been stored in a warm space prior to the installation. At a construction site, heating of the pipes can also be performed by using a hot air blower. Heating the pipes over an open fire is prohibited.

Pipe coverage



The flexibility of the Uponor Ecoflex pipes allows for problem-free adaptation on-site to almost any routing conditions. It is possible to route over or under existing lines, while obstacles can simply be avoided. Even laying the pipe system under a ground water table of 3 meter (0,3 bar) is permitted.

The system requires the excavation of only a narrow trench of low depth. Laying does not normally need anyone to get into the trench except at the pipe joint and branch locations. Suitable working space should be created for this purpose at the joint and branch sites. Whenever the pipe direction changes, the bending radii must not be smaller than the permitted minimums for the various pipe systems.

It is convenient to do all the excavation on one side of the trench. The pipe is then rolled out on the free side, and laid directly in the trench. It is essential to avoid damaging the jacket pipe.

A bed of sand without stones is specified. The sand grain size should be between 0 and 2/3 mm. Never include any objects with sharp edges or points in the trench. Bedding the pipeline carefully (at least 10 cm above and below the jacket pipe, and to the walls of the ditch) has a crucial effect on the durability of the jacket pipe.

When deciding the minimum coverage, the possibility of damage from subsequent building work during the entire lifetime of the construction should be kept in mind. The filling material should be compacted in layers, and a machine should be used for this above 500 mm coverage. When this has been done, lay the line warning strip and fill the trench.

When covered to a depth of $h = 0,5$ metres up to a maximum of 6 metres, the Uponor jacket pipe can withstand soil and heavy traffic loads. The certificate, based on ATV DVWK-A127, demonstrates that our pipes, when laid in accordance with defined conditions, are suitable for heavy traffic load (SWL 60 = 60 t) according to worksheet ATV-A 127. The ring stiffness of the jacket pipe is proved according EN ISO 9969 to be able to withstand 4 kN/m^2 (class SN4).

Minimum coverage without stress from traffic loading

Caution!
Local frost limits have not been taken into account.

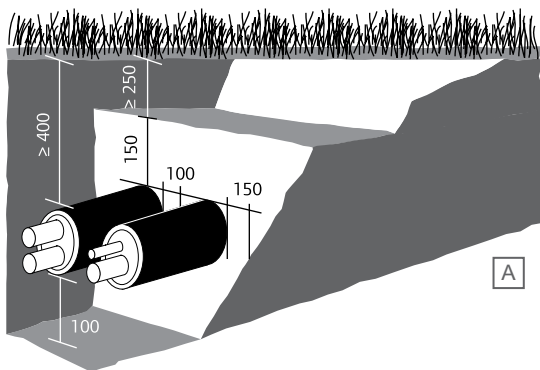

ED0000035

Coverage with traffic loading according to SLW 60 tons

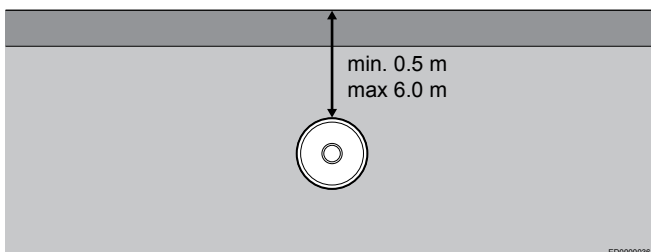

ED0000036

Pipe Anchoring

Note
Anchoring must not be conducted directly on the medium pipe.

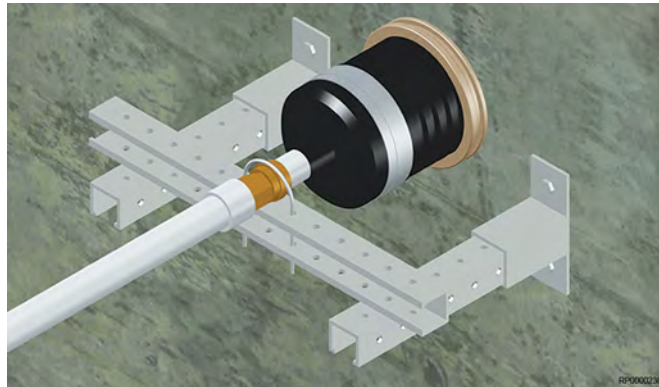

Small pipe sizes (medium pipe OD $\leq 50 \text{ mm}$) can normally be anchored with the holders of the joined piece of the equipment. Large pipe sizes (medium pipe OD $> 50 \text{ mm}$) must be anchored using a separate fixed point joint.

The expansion behaviour of PEX material leads to slight changes in the length of the medium pipe therefore a tension-free connection must be provided by a pipe bend or a fixed point joint.

Pipe clamp to pipe elbow

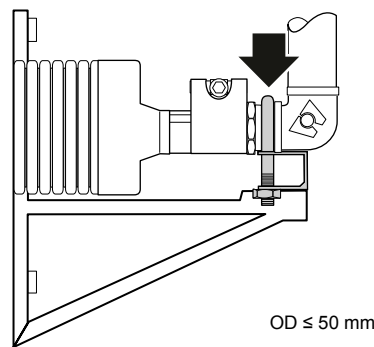

S0000414

Attaching the pipe clamp to the pipe elbow (OD $\leq 50 \text{ mm}$)

Pipe clamp to fixed point joint

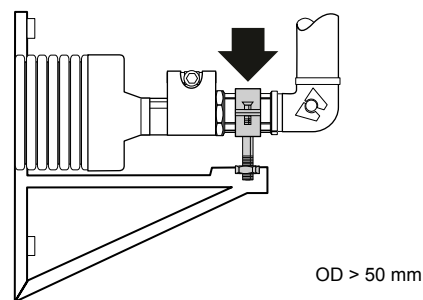

S0000415

Attaching the pipe clamp to the Wipex fixed point joint (OD $> 50 \text{ mm}$)

Mounting on the wall or ceiling

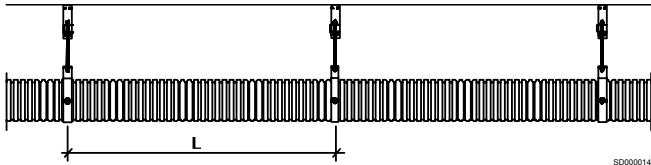

SD0000141

Jacket pipe OD [mm]	Maximum support interval [m]
68	0,6
90	0,8
140	1,0
145	1,0
175	1,2
200	1,4
250	1,6

The pipes can also be mounted on the wall or on the ceiling using brackets or placing them on a cable shelf. In order to prevent the pipe from bending, install the brackets according to the adjacent table. The table sets out maximum support intervals for horizontal and vertical mounting in order to prevent the pipes from hanging. If required, the interval of the brackets can be shortened.

6.3 Mounting of components and accessories

Ecoflex Rubber end caps

Note

The rubber end caps must be fitted to the ends of the jacket pipes before making a fitting connection to a medium pipe.

Note

Observe the dimensions of the insulating kit.

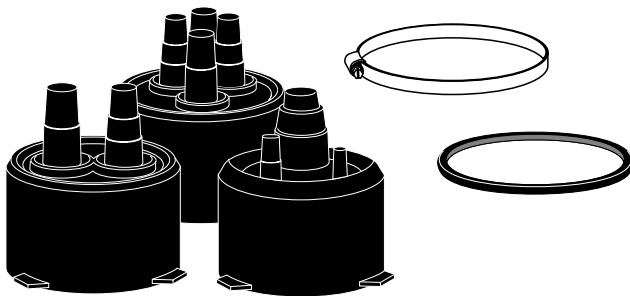

CD0000212

Ecoflex Insulation set

Note

Joints should not be located underneath roads because this makes access difficult and heavy vehicles could damage the joint.

If the H-insulation set is installed underneath roads it is necessary to use a concrete slab above the joint to distribute the heavy traffic load.

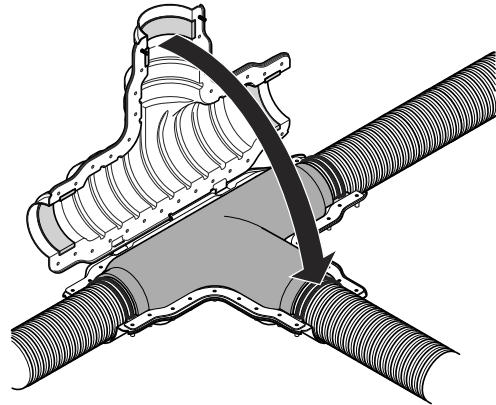

SI0000422

All sets cover different dimensions of jacket pipes and they fit single and twin pipes equally well. All necessary components like foam half shells, bolts and sealing kit are included.

Ecoflex House connection elbows

Note

For the connection of the House connection elbow Twin 40/160 with the insulation set, the reducer ring 160 mm is not part of standard delivery and must be ordered separately.

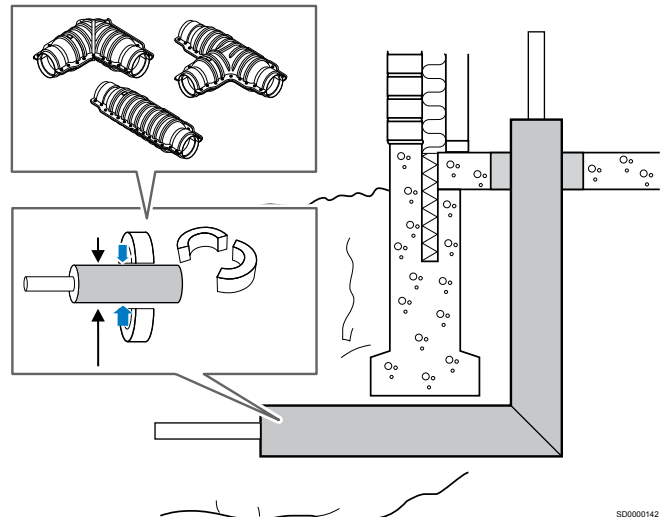

SD0000142

The Uponor Ecoflex House connection elbows are connected with the Ecoflex insulation sets (except for the House connection elbow Twin 75, which is connected with the jacket joint set 250).

Ecoflex chambers

!	<p>Note</p> <p>Joints should not be located underneath roads because this makes access difficult and heavy vehicles could damage the joint.</p>
!	<p>Note</p> <p>Without load distribution above the chamber, the chamber can handle, with a 50 cm sand cover, a short-term load of 3000 kg (6000 kg/m²) - e.g. a tractor crossing. The chamber lid can withstand a continuous load of up to 500 kg (1000 kg/m²), e.g. a parked car.</p>
!	<p>Note</p> <p>At higher traffic load it is necessary to use a concrete slab above the chamber to distribute the weight.</p>

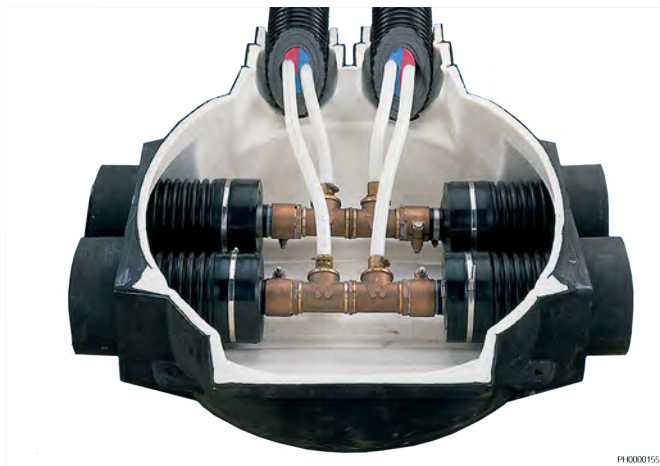

PH0000155

Ecoflex chamber installation examples

Heating supply to 2 houses

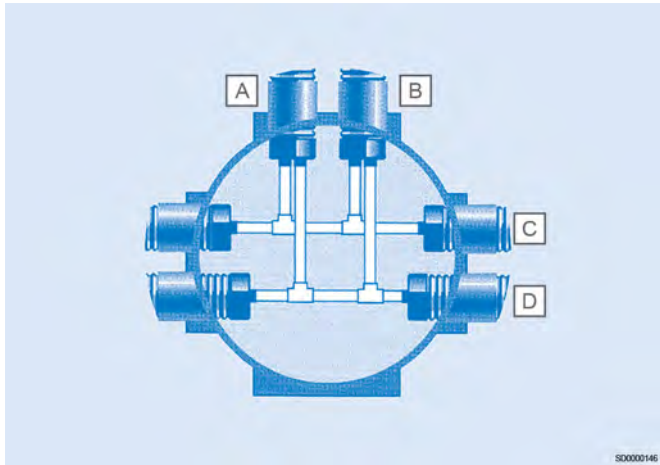

S00000146

Item	Description
A	Thermo Twin, house 1
B	Thermo Twin, house 2
C	Thermo Single, heating main line, flow
D	Thermo Single, heating main line, return

Heating supply to 4 houses

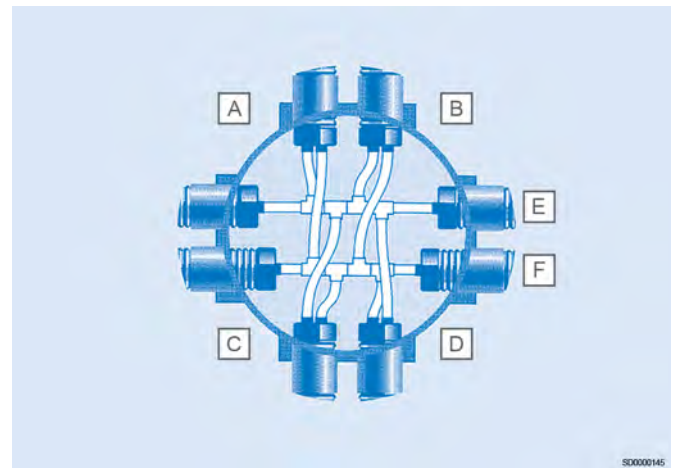

S00000145

Item	Description
A	Thermo Twin, house 1
B	Thermo Twin, house 2
C	Thermo Twin, house 3
D	Thermo Twin, house 4
E	Thermo Single, heating main line, flow
F	Thermo Single, heating main line, return

Heating and warm tap water to the house

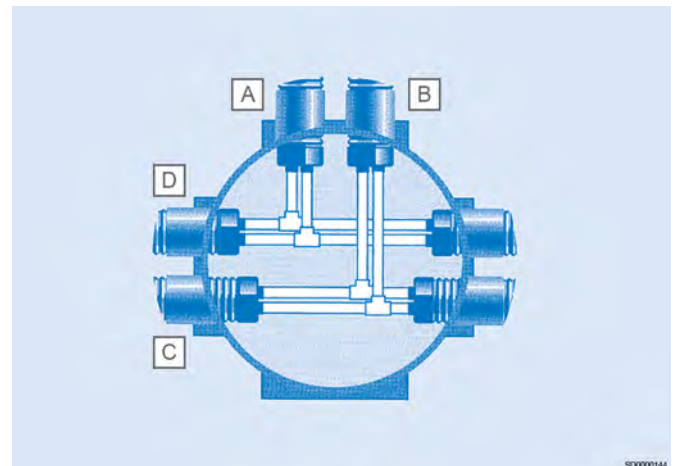

S00000144

Item	Description
A	Aqua Twin, house 1
B	Thermo Twin, house 1
C	Thermo Twin heating, main line, flow and return
D	Aqua Twin warm tap water, main line, flow and circulation

Heating and warm tap water to 2 houses with Quattro

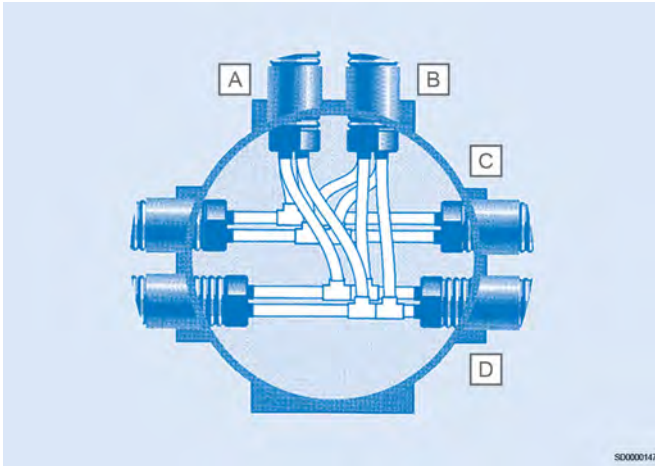

Item	Description
A	Quattro, house 1
B	Quattro, house 2
C	Aqua Twin warm tap water, main line, flow and circulation
D	Thermo Twin heating, main line, flow and return

6.4 Installation of Ecoflex Supra Standard and PLUS pipes

Uponor Ecoflex Supra pipes should be dug and covered at the depth of at least 10 – 30 cm. All Supra pipes can withstand continuous freezing and, if conditions so require, they can be installed directly on the ground or snow. When installing Supra pipes freely on the ground, adequate mechanical protection must be ensured and the pipe must be protected from direct contact with sharp objects and tree stumps. If vehicles travel over the pipes, they must be adequately protected using a casing pipe that can withstand the weight of vehicles running over it.

Supra pipes can be installed as an overhead line. It must be supported with adequate holders according to the manufacturer's instructions.

The thermal expansion of the medium pipe must be taken into account according to the prevailing installation conditions, for example $\Delta t = 10 \text{ }^\circ\text{C}$, $l = 100 \text{ m} \Rightarrow \Delta l = 18 \text{ cm}$. The medium pipe must be anchored at the joints if no thermal movement is required to take place.

When feeding the pipe through structures, Supra pipes must be protected with, for example, a plastic casing pipe sealed into the structure.

When joining medium pipes, reserve approximately 0,5 m of free frost protection cable at the end of each pipe for connections. In locations with extra thermal loss (flanges, valves, etc.), some frost protection cables should be wrapped around the part in question to compensate for the larger thermal loss (cables may intersect).

The pressure pipe must be filled with water before the power is switched on to prevent damage to the medium pipe. If the pipe has to be assembled in extremely cold temperatures, it must first be defrosted and bent on a larger coil. When the pipe has warmed up enough at room temperature, it can be wound on a smaller coil.

Detailed instructions for installing the connection end, end seal, branch tee and straight joint for both Ecoflex Supra PLUS and Standard pipes are given in respective Uponor IM documents.

6.5 Electrical installations of Ecoflex Supra cables and control units

	Warning!
	General safety regulations must be complied with during the installation. The frost protection cable can only be connected by a qualified electrician. Do not damage the frost protection cable during installation!
	Note
	In temperatures below 0 °C, the resistance of the cable is very small. When switching the cable on in low temperatures, the protection (fuse) may go off. The protection can be altered temporarily in order to increase the cable temperature and resistance and to keep the cable switched on.

The frost protection cable and its connection box must usually placed on a class A structure so that, in normal use, they do not cause a temperature higher than 80 °C in combustible construction materials or a temperature higher than 175 °C when a fault occurs.

After installation, there must not be any tensile stress on the cable. Please take into consideration the thermal elongation of the plastic pipe in the cable connections.

Besides the frost protection cable, no other power consumption shall be connected to the same circuit. It must be possible to separate the frost protection cable installation from the network either with a common or circuit specific switch that can also be connected to the control circuit. The switch must bear position indicator markings and a label explaining the installation, for example, "Water pipe non-freeze heating".

The network connection takes place through the control unit. The protective earth metal cord on the frost protection cable must not be used as a neutral conductor. The supply cable must always be equipped with a separate shielded wire in the neutral conductor (General safety regulations).

The insulation resistance of the frost protection cable must be measured before covering and commissioning the pipes. The measurement is conducted using direct-current voltage 500 V – 2,5 kV DC. The insulation resistance should be $R > 20 \text{ M}\Omega$. Connection must be made so that the insulation resistance of the frost protection cable can be easily measured later in an accessible location.

Record the measurement results on the electric test protocol, which can be downloaded from the Uponor local web page.

The extension, tee branching and connection of the frost protection cable to the supply cable are conducted using approved shrinking plastic couplings. The cables can touch in the joints, because the self-regulating frost protection cable cannot overheat.

More detailed installation instructions for electrical cable connections are given in IM documents for Uponor Ecoflex Supra PLUS and Standard Cable Set 1 and 2 respectively. Instructions for electrical connections of Supra PLUS control unit and Supra Standard thermostat ETN4 are given in their respective IM documents.

Technical drawings

The technical drawings must include:

- the type of frost protection cable.
- the number of frost protection cables.
- the placement of frost protection cables.
- the maximum permissible operating temperature for the cable.

6.6 Pressure and leak testing

Note

All installations must be carried out in accordance with current local standards and regulations!

Always consider your local requirements before performing any tests.

Tap water application (DIN 1988 Part 2)

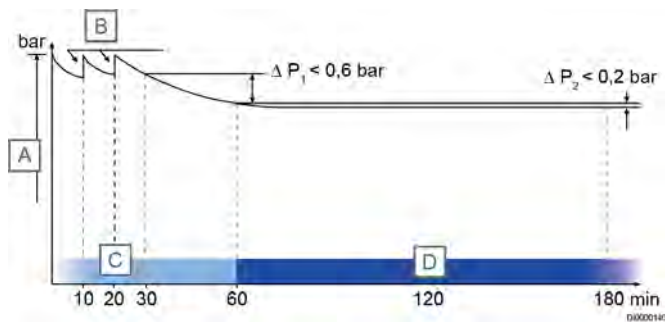

Item	Description
A	Operating gauge pressure +5 bar
B	Re-pressurise
C	Preliminary test
D	Main test

Performance of the pressure test

The pipes that have been assembled, but not yet covered, are to be filled with filtered water in such a way as to exclude air. The pressure test is carried out as a preliminary and a main test.

Preliminary test

For the preliminary test, a test pressure equal to the permitted operating pressure plus an additional 5 bar is applied; this must be repeated twice within 30 minutes, and with an interval of 10 minutes between tests. Following this, and after a test period of a further 30 minutes, the test pressure must not fall by more than 0,6 bar (0,1 bar every 5 minutes), and no leaks may appear.

Main test

The main test is to be carried out immediately after the preliminary test. The duration of the test is 2 hours. In this test, the test pressure measured at the end of the preliminary test must not fall by more than 0,2 bar during the following two hours. Leaks may not be found at any point in the tested installation.

Plastic pipes

The properties of the materials of which plastic pipes are made cause the pipe to expand during the pressure test, and this has an effect on the test result.

The result of the test can also be affected by temperature differences between the pipe and the test medium, due to the high coefficient of thermal expansion of plastic materials. A temperature change of 10 K here corresponds approximately to a change in pressure of between 0,5 and 1 bar. For this reason it is necessary to keep the temperature of the test medium as constant as possible when parts of the installation comprising plastic pipes are being subjected to the pressure test.

Check all the joints visually at the same time as the pressure test. Experience shows that relatively small leaks cannot always be detected simply by watching the pressure gauge. When the pressure test is complete, flush the pipes thoroughly.

Pressure test report

The test must be documented in a pressure test report by the responsible specialist, taking into account the materials used. The tightness of the system must be verified and confirmed.

This report is available at the Uponor services download center.

<https://www.uponor.com/doc/1120219>



Heating pipes (DIN 18380)

Note

The pressure test must take place before operation of the system begins. In order to ensure that the joints are not leaking, the test must be carried out before they are insulated and closed.

Performance of the pressure test

The test pressure must be maintained for 2 hours, and must not fall by more than 0,2 bar. No leaks may appear during this period. As soon as possible after the cold water pressure test, the temperature is to be increased to the highest hot water temperature on which the calculations were based, in order to check whether the installation remains free from leaks even at the maximum temperature.

When the installation has cooled down, the heating pipes are finally to be checked to see that there are no leaks at the joints.

The pipes that have been assembled, but not yet covered, are to be filled with filtered water in such a way as to exclude air. Heating pipes are to be tested using a pressure that is 1,3 times the total pressure (static pressure) of the installation, but that is at least 1 bar gauge pressure at every part of the installation. Only pressure gauges capable of accurately displaying pressure changes of 0,1 bar may be used. The pressure gauge is to be placed at the lowest possible part of the installation.

Temperature equalisation between the ambient temperature and the temperature of the water with which the pipes are filled is to be achieved by a suitable waiting time after establishing the test pressure. After this waiting period it may be necessary to re-establish the test pressure.

Pressure test report

The test must be documented in a pressure test report by the responsible specialist, taking into account the materials used. The tightness of the system must be verified and confirmed.

This report is available at the Uponor services download center.

<https://www.uponor.com/doc/1120218>



7 Technical data

7.1 Uponor PE-Xa pipes

Mechanical properties

Description		Value	Unit	Test norm
Density	-	938	kg/m ³	-
Tensile strength	20 °C	19-26	N/mm ²	DIN 53455
	100 °C	9-13	N/mm ²	
E-module	20 °C	800-900	N/mm ²	DIN 53457
	80 °C	300-350	N/mm ²	
Ultimate elongation	20 °C	350-550	%	DIN 53455
	100 °C	500-700	%	
Impact strength	-140 °C	No rupture	kJ/m ²	DIN 53453
	20 °C	No rupture	kJ/m ²	
	1000 °C		kJ/m ²	
Moisture absorption	22 °C	0,01	mg/4 d	DIN 53472
Pipe friction	-	0,007	mm	
Oxygen permeability Uponor evalPEX	80 °C	3,6	mg/m ² *d	DIN 17455
Fire classification		E		EN 13501-1

Thermal properties

Description		Value	Unit	Test norm
Temperature range		-50 to 95	°C	
Linear expansion coefficient	20 °C	1,4x10 ⁻⁴	m/m·K	DIN 53752
	100 °C	2,05x10 ⁻⁴	m/m·K	
Softening temperature		+133	°C	DIN 53460
Specific heat		2,3	kJ/kg·K	
Coefficient of thermal conductivity	20 °C	0,35	W/m·K	DIN 4725

Weight and volume

Pipe dimension OD x s [mm]	Inner diameter ID [mm]	Weight [kg/m]	Water volume [l/m]
SDR 11 (PN 6)			
25 x 2,3	20,4	0,16	0,33
32 x 2,9	26,2	0,25	0,54
40 x 3,7	32,6	0,40	0,83
50 x 4,6	40,8	0,63	1,31
63 x 5,8	51,4	1,00	2,07
75 x 6,8	61,4	1,40	2,96
90 x 8,2	73,6	2,02	4,25
110 x 10	90,0	3,01	6,36
125 x 11,4	102,2	3,90	8,20
SDR 7,4 (PN 10)			
18 x 2,5	13,0	0,12	0,13
20 x 2,8	14,4	0,14	0,16
25 x 3,5	18,0	0,23	0,25
32 x 4,4	23,2	0,37	0,42
40 x 5,5	29,0	0,57	0,66
50 x 6,9	36,2	0,90	1,03
63 x 8,6	45,8	1,41	1,65
75 x 10,3	54,4	2,01	2,32
90 x 12,3	65,4	2,88	3,36
110 x 15,1	79,8	4,31	5,00

Comparative tables

PN 6 / SDR 11 pipes

Uponor PE-Xa pipes SDR 11		Steel pipes	
Pipe dimension OD x s [mm]	Inner diameter ID [mm]	DN	OD/ID [mm]
25 x 2,3	20,4	20	26,9/22,9
32 x 2,9	26,2	25	33,7/28,1
40 x 3,7	32,6	32	42,4/37,2
50 x 4,6	40,8	40	48,3/43,1
63 x 5,8	51,4	50	60,3/54,5
75 x 6,8	61,4	65	76,1/70,3
90 x 8,2	73,6	80	88,9/82,5
110 x 10	90,0	100	14,3/107,1
125 x 11,4	102,2	125	139,7/132,5

OD - outer diameter, ID - inner diameter

The table shows the corresponding dimensions of PEX and steel pipes.

PN 10 / SDR 7,4 pipes

Uponor PE-Xa pipes SDR 7,4		Copper pipes	
Pipe dimension OD x s [mm]	Inner diameter ID [mm]	DN	OD/ID [mm]
25 x 3,5	18,0	20	22/20
32 x 4,4	23,2	25	28/26
40 x 5,5	29,0	32	35/32,6
50 x 6,9	36,2	40	42/39,6
63 x 8,6	45,8	50	54/51,0
75 x 10,3	54,4	65	64/61
90 x 12,3	65,4	70	76,1/72,1
110 x 15,1	79,8	80	88,9/84,9

OD - outer diameter, ID - inner diameter

The table shows the corresponding dimensions of PEX and copper pipes.

Long-term properties

Uponor PE-Xa pipes have been type approved by DVGW since 1977. The approval is based on testing performed by international testing institutes. Stress tests show that at a temperature of 70 °C and a pressure level of 10 bar in continuous operation the pipe has an estimated service life of more than 50 years.

Thermal elongation

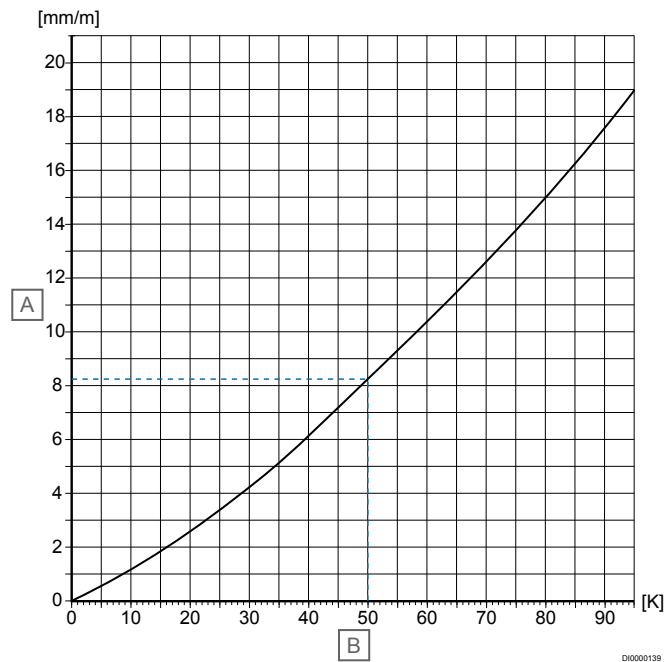

Item	Description
A	Change in length (mm/m)
B	Temperature difference (K)

Example thermal elongation of PE-Xa pipe

Description	Value
Installation temperature	20 °C
Operation temperature	70 °C
Result	
Temperature difference	(70 °C - 20 °C) = 50 K
Elongation (change in length)	8,2 mm/m
A 5 m pipe would expand by 41 mm.	

Tap water pipe

The approved PEX pipes are suitable for carrying warm tap water up to 95 °C, and at a maximum pressure of 10 bar. The Uponor PE-Xa pipe is manufactured, in accordance with EN 15875-2, with a diameter/wall thickness ratio SDR of 7,4.

Heating pipe

Uponor heating pipes of PE-Xa are coated with an EVOH layer in accordance with DIN 4726 to prevent oxygen diffusion. They are therefore particularly suitable for carrying heating water at up to 95 °C and at a maximum pressure of 6 bar. The diameter/wall thickness ratio is in accordance with SDR 11 and SDR 7,4.

7.2 Classification of service conditions

EN ISO 15875 Plastics piping systems for hot and cold water installations - Cross-linked polyethylene (PE-X)

Uponor PE-Xa pipe systems are designed according to EN ISO 15875 (Plastics piping systems for hot and cold water installations - crosslinked polyethylene (PE-X)).

Application class	Operating temperature T_D [°C]	Time at T_D [years]	T_{max} [°C]	Time at T_{max} [years]	T_{mal} [°C]	Time at T_{mal} [hours]	Typical application
1 ^a	60	49	80	1	95	100	Hot water distribution (60 °C)
2 ^a	70	49	80	1	95	100	Hot water distribution (70 °C)
4 ^b	20	2,5	70	2,5	100	100	Underfloor heating and low temperature radiators
	Followed by						
	40	20					
	Followed by						
	60	25					
	Followed by (see next column)		Followed by (see next column)				
5 ^b	20	14	90	1	100	100	High temperature radiators
	Followed by						
	60	25					
	Followed by						
	80	10					
	Followed by (see next column)		Followed by (see next column)				

^a) In order to comply with national regulations, a country may apply either class 1 or 2.

^b) Where more than one operating temperature is shown for any class, the times must be added up, e.g. the operating temperature profile for 50 years for class 5 is: 20 °C for 14 years followed by 60 °C for 25 years, 80 °C for 10 years, 90 °C for one year and 100 °C for 100 h.

Note! For values exceeding those in the table for T_D , T_{max} and T_{mal} , this standard is not applicable.

Source: EN ISO 15875-1

EN 15632 - District heating pipes - Pre-insulated flexible pipe systems

The Uponor Ecoflex pre-insulated PE-Xa heating pipes (Ecoflex VIP Thermo, Thermo and Varia) and related system components are designed according to EN 15632 District heating pipes – Pre-insulated flexible pipe systems – Part 1: Classification, general - Requirements and test methods and Part 3: Non bonded system with plastic service pipes.

Operating pressure

Uponor pre-insulated PE-Xa pipe systems are, in accordance with EN 15632-1 and 3, designed for continuous operating pressures of 6 bar (SDR 11) and 10 bar (SDR 7,4).

Operating temperatures and service life

The Uponor pre-insulated PE-Xa pipe systems according to EN 15632 are designed for a service life time of at least 30 years when operated at the following temperature profile: 29 years at 80 °C + 7760 h at 90 °C + 1000 h at 95 °C + 100 h at 100 °C.

Other temperature/time profiles can be applied in accordance with EN ISO 13760 (Miner's Rule). Further information is given in EN 15632 Part 3, Annex A. The maximum operating temperature shall not exceed 95 °C.

Long-term hydrostatic pressure resistance of pipes made from PE-X according to EN ISO 15875

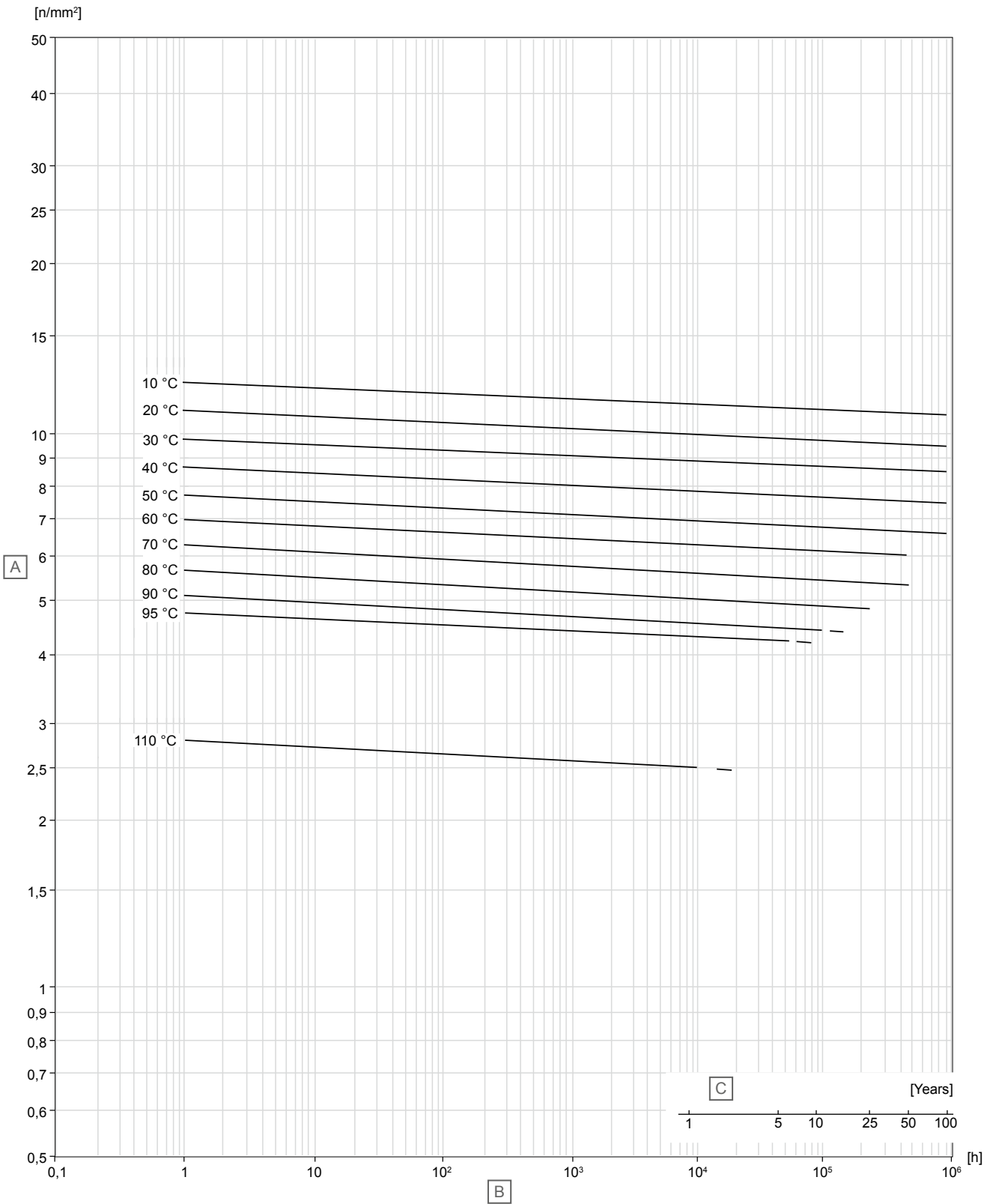

D0000147

Item	Description
A	Stress intensity $[\text{N/mm}^2] = [\text{MPa}]$
B	Service life [h]
C	Service life [years]

7.3 Uponor PE-HD medium pipes

Uponor Ecoflex Supra PE 100 RC material properties

Property	Value	Unit	Standard
Density at 23 °C	960	kg/m ³	ISO 1183-1, Method A
Resistance to slow crack growth	> 65	N/mm ²	ISO 18488
Tensile strain at break (50 mm/min)	> 600	%	ISO 572-2
Tensile stress at yield (50 mm/min)	25	N/mm ²	ISO 572-2
Tensile modulus (1 mm/min)	1100	N/mm ²	ISO 572-2
Carbon black content	2 – 2,5	%	ISO 6964
Thermal conductivity at 20 °C	0,38	W/m·K	DIN 52612
Oxidation induction time (210 °C)	> 20	min	ISO 11357-6
Operation temperature	- 10...+ 20 (16 bar)	°C	-
Thermal linear expansion coefficient	1,8 x 10 ⁻⁴	1/ °C	DIN 53752
Fire classification	B2	-	DIN 4102 part 2
	E		EN 13501 part 1

The medium pipe for Uponor Ecoflex Supra, Supra PLUS and Supra Standard pipes is produced in PE-HD (PE 100 RC) material. The pipes are designed especially for transporting cold potable water and/or for use in cooling water networks.

The PE-HD medium pipe used in Supra, Supra Plus and Supra Standard have an DVGW, WRAS, ACS and Instra-Cert certification for transporting potable water.

Service life: PE100 medium pipe

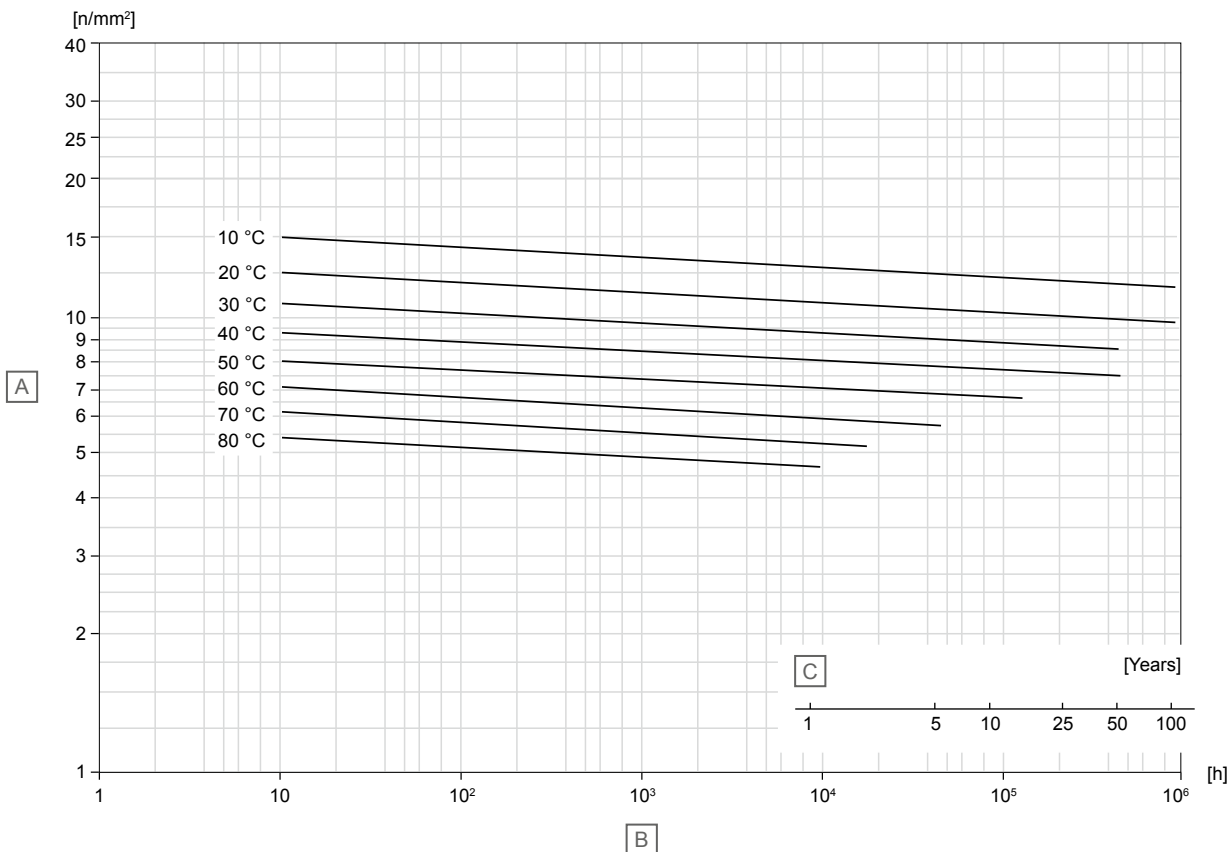

D0000148

Item	Description
A	Stress intensity [N/mm ²] = [MPa]
B	Service life [h]
C	Service life [years]

7.4 Insulation materials

VIP insulation

Property	Value
Thermal conductivity - λ_{10}	< 0,0035 W/m·K
Thermal conductivity - λ_{50}	< 0,0042 W/m·K
Operating temperature	-75 – 100 °C (temporary up to 130 °C possible)
Moisture resistance	0 – 70 % relative humidity (until 50 °C)
Compressive strength at 10 % compression	~ 120 kPa according to EN 826
Fire classification	F according to EN 13501-1

PE-X insulation

Property	Value
Thermal conductivity - λ_{10}	< 0,037 W/m·K
Thermal conductivity - λ_{50}	< 0,041 W/m·K
Density	~ 28 kg/m ³ , According to DIN 53420
Tensile strength	28 N/cm ² , According to DIN 53571
Operating temperature	-40 — +95 °C
Water absorption	< 1,0 Volume % According to EN 489
Fire classification	B2 according to DIN 4102 E according to EN 13501-1
Compressive strength 50 % deformation	73 kPa According to DIN 53577
Water vapour transmission / 10 mm thickness	1,55 g/m ² d According to DIN 53429

7.5 Jacket pipe material

Property	Value
Material	PE-HD
UV-stabilised	Yes
Fire classification	B2 according to DIN 4102 E according to EN 13501-1
Density	957 – 959 kg/m ³ According to ISO 1183
Modulus of elasticity	~ 1000 MPa According to ISO 527-2

7.6 Electrical components

Uponor Ecoflex Supra Standard thermostat ETN4

Description	Value
Supply voltage	230V AC \pm 10% 50/60 Hz
Standby power	0,5 Watt
Output relay SPST	16A, resistive load or 1A, inductive load
Interrupter	2-pole, 16A
Control temperature range (extended)	-19,5 to +70 °C
Control accuracy	\pm 0,4 °C
Floor limit range	-19,5/+70 °C
Ambient temperature	-19,5/+55 °C during operation
Night setback relative	-19,5/+30 °C
Night setback regulator	1-100 %
Frost protection Abs.	0-10 °C
Frost protection regulator	1-100 %
Regulation principle	PWM/PI or ON/OFF
Housing	IP20
Sensor type	NTC (12K Ω) 3 m max. 100 m
Display	Segment - backlit
Dimensions (H/W/D)	89,5/52,9/57,3 mm

Supra standard constant resistant cable

Description	Value
External dimensions	Width 12 mm Thickness 7 mm
Smallest bending radius	25 mm
Supply voltage	230 V/400 V
The maximum permissible operating temperature	+ 70 °C
Max. installation length	White cable: (2 x 0,05 Ω /m + Cu) 400 m/230 V or 700 m/400 V Yellow cable: (2 x 0,48 Ω /m + Cu) 180 m/230 V or 300 m/400 V
Nominal output (on the surface of an insulated metal pipe +5 °C)	Max. 25 W/m

Uponor Ecoflex Supra PLUS control unit

Description	Value	
Operating voltage	230 V AC	
Rated power	1500 W	
Operating temperature	-20 ... +45 °C	
Housing class	IP 23	
Indication by indicator light	Effective part	
Adjustment range with thermostat	0 ... 10 °C	
Adjustment range with operation	10 % ... 100 %	
Length of sensor cable	10 m	
Values of sensor	T °C	R kΩ
	0	29
	5	23
	10	18
	15	15
	20	12
	25	10

Supra PLUS Self-regulating cable

Description	Value
External dimensions	Width 12,5 mm Thickness 5,2 mm
Smallest bending radius	13 mm
Supply voltage	230 V
The maximum permissible operating temperature	Continuous 65 °C Momentary 85 °C
Max. installation length	100 m 10 A 150 m 16 A
Nominal output (on the surface of an insulated metal pipe +5 °C)	10 W/m

Uponor

Uponor GmbH

Industriestraße 56,
D-97437 Hassfurt, Germany

1120217 v2_12_2021_EN
Production: Uponor/ELO/ALO

Uponor reserves the right to make changes, without prior notification,
to the specification of incorporated components in line with its policy of
continuous improvement and development.



www.uponor.com