

MANUALS



Instructions and recommendations **IE**
Installer
User
Maintenance technician

VICTRIX ZEUS

25 - 32

1.042022ENG



INDEX

Dear Customer.....	4	3	Instructions for maintenance and initial check.....	42
General recommendations.....	4	3.1	General warnings.....	42
Safety symbols used.....	5	3.2	Initial check.....	42
Personal protective equipment.....	5	3.3	Yearly appliance check and maintenance.....	43
		3.4	Hydraulic Diagram.....	44
1 Boiler installation.....	6	3.5	Wiring diagram.....	45
1.1 Installation recommendations.....	6	3.6	Removable memory.....	47
1.2 Main dimensions.....	9	3.7	Troubleshooting.....	47
1.3 Minimum installation distances.....	9	3.8	Converting the boiler to other types of gas.....	48
1.4 Antifreeze protection.....	10	3.9	Checks following conversion to another type of gas.....	48
1.5 Boiler connection unit.....	11	3.10	Calibration type involving the replacement of a component.....	49
1.6 Gas connection.....	11	3.11	Complete calibration function.....	49
1.7 Hydraulic connection.....	12	3.12	CO ₂ adjustment.....	50
1.8 Electrical connection.....	13	3.13	Fast calibration.....	50
1.9 Remote controls and room chrono-thermostats (Optional).....	13	3.14	Flue test.....	51
1.10 External temperature probe (Optional).....	14	3.15	Programming the P.C.B.....	51
1.11 Immergas flue systems.....	15	3.16	"Chimney sweep" function.....	55
1.12 Tables of resistance factors and equivalent lengths of "green range" flue system components.....	16	3.17	Pump anti-block function.....	55
1.13 Outdoor installation in partially protected area.....	18	3.18	Three-way anti-block system.....	55
1.14 Concentric horizontal kit installation.....	20	3.19	Radiators antifreeze function.....	55
1.15 Concentric vertical Kit installation.....	21	3.20	Periodical P.C.B. self-check.....	55
1.16 Separator kit installation.....	22	3.21	Automatic vent function.....	55
1.17 Adaptor C9 kit installation.....	24	3.22	Casing removal.....	56
1.18 Ducting of flues or technical slots.....	26	4	Technical data.....	58
1.19 Configuration type B, open chamber and fan assisted for indoors.....	26	4.1	Variable heat output.....	58
1.20 Flue exhaust to flue/chimney.....	27	4.2	Combustion parameters.....	59
1.21 Flues, chimneys and chimney caps.....	27	4.3	Technical data table.....	60
1.22 Water treatment system filling.....	28	4.4	Key for Data nameplate.....	61
1.23 System filling.....	28	4.5	Technical parameters for combination boilers (in compliance with Regulation 813/2013).....	62
1.24 Filling the condensate drain trap.....	28	4.6	Product fiche (in compliance with Regulation 811/2013).....	63
1.25 Gas system start-up.....	28	4.7	Parameters for filling in the package fiche.....	64
1.26 Boiler start-up (Ignition).....	29			
1.27 Circulation pump.....	29			
1.28 Circulation pump with new wave 3 electronics.....	29			
1.29 Kits available on request.....	31			
1.30 Boiler components.....	32			
2 Instructions for use and maintenance.....	33			
2.1 General warnings.....	33			
2.2 Cleaning and maintenance.....	35			
2.3 Control panel.....	35			
2.4 Using the boiler.....	36			
2.5 Fault and anomaly signals.....	37			
2.6 Information Menu.....	40			
2.7 Boiler shutdown.....	40			
2.8 Restore central heating system pressure.....	40			
2.9 Draining the system.....	40			
2.10 Draining the domestic hot water circuit.....	40			
2.11 Storage tank draining.....	41			
2.12 Antifreeze protection.....	41			
2.13 Cleaning the case.....	41			
2.14 Decommissioning.....	41			
2.15 Gas system not used for periods over 12 months.....	41			

Dear Customer,

Our compliments for having chosen a top-quality Immergas product, able to ensure well-being and safety for a long period of time. As an Immergas Customer, you can also count on a qualified after-sales service, prepared and updated to guarantee constant efficiency of your boiler. Read the following pages carefully: you will be able to draw useful tips on the correct use of the device, compliance of which will confirm your satisfaction with the Immergas product.

For assistance and routine maintenance, contact Authorised Immergas Service Centres: they have original spare parts and are specifically trained directly by the manufacturer.

GENERAL RECOMMENDATIONS

This book contains important information for the:

Installer (section 1);

User (section 2);

Maintenance Technician (section 3).

- The user must carefully read the instructions in the specific section (section 2).
- The user must limit operations on the appliance only to those explicitly allowed in the specific section.
- The appliance must be installed by qualified and professionally trained personnel.
- The instruction booklet is an integral and essential part of the product and must be given to the new user in the case of transfer or succession of ownership.
- It must be stored with care and consulted carefully, as all of the warnings provide important safety indications for installation, use and maintenance stages.
- In compliance with the legislation in force, the systems must be designed by qualified professionals, within the dimensional limits established by the Law. Installation and maintenance must be performed in compliance with the regulations in force, according to the manufacturer's instructions and by professionally qualified staff, meaning staff with specific technical skills in the plant sector, as provided for by Law.
- Improper installation or assembly of the Immergas device and/or components, accessories, kits and devices can cause unexpected problems for people, animals and objects. Read the instructions provided with the product carefully to ensure proper installation.
- This instructions manual provides technical information for installing Immergas products. As for the other issues related to the installation of products (e.g. safety at the workplace, environmental protection, accident prevention), it is necessary to comply with the provisions of the standards in force and the principles of good practice.
- All Immergas products are protected with suitable transport packaging.
- The material must be stored in a dry place protected from the weather.
- Damaged products must not be installed.
- Maintenance must be carried out by skilled technical staff. For example, the Authorised Immergas Service Centre that represents a guarantee of qualifications and professionalism.
- The device must only be destined for the use for which it has been expressly declared. Any other use will be considered improper and therefore potentially dangerous.
- If errors occur during installation, operation and maintenance, due to non-compliance with technical laws in force, standards or instructions contained in this booklet (or however supplied by the manufacturer), the manufacturer is excluded from any contractual and extra-contractual liability for any damages and the device warranty is invalidated.



The company **IMMERGAS S.p.A.**, with registered office in via Cisa Ligure 95 42041 Brescello (RE), declares that the design, manufacturing and after-sales assistance processes comply with the requirements of standard **UNI EN ISO 9001:2015**.

For further details on the product CE marking, request a copy of the Declaration of Conformity from the manufacturer, specifying the appliance model and the language of the country.

The manufacturer declines all liability due to printing or transcription errors, reserving the right to make any modifications to its technical and commercial documents without forewarning.

SAFETY SYMBOLS USED.



GENERIC HAZARD

Strictly follow all of the indications next to the pictogram. Failure to follow the indications can generate hazard situations resulting in possible harm to the health of the operator and user in general.



ELECTRICAL HAZARD

Strictly follow all of the indications next to the pictogram. The symbol indicates the appliance's electrical components or, in this manual, identifies actions that can cause an electrical hazard.



MOVING PARTS

The symbol indicates the appliance's moving components that can cause hazards.



HOT SURFACES

The symbol indicates the appliance's very hot components that can cause burns.



SHARP SURFACES

The symbol indicates the appliance's components or parts that can cause cuts if touched.



EARTH TERMINAL CONNECTION

The symbol identifies the appliance's earth terminal connection point.

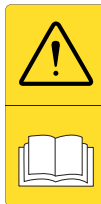

READ AND UNDERSTAND THE INSTRUCTIONS

Read and understand the appliance's instructions before performing any operation, carefully following the indications provided.



INFORMATION

Indicates useful tips or additional information.



The user must not dispose of the appliance at the end of its service life as municipal waste, but send it to appropriate collection centres.

PERSONAL PROTECTIVE EQUIPMENT.



SAFETY GLOVES



SAFETY GOGGLES



SAFETY FOOTWEAR

1 BOILER INSTALLATION.

1.1 INSTALLATION RECOMMENDATIONS.

ATTENTION:

operators who install and service the appliance must wear the personal protective equipment required by applicable law.

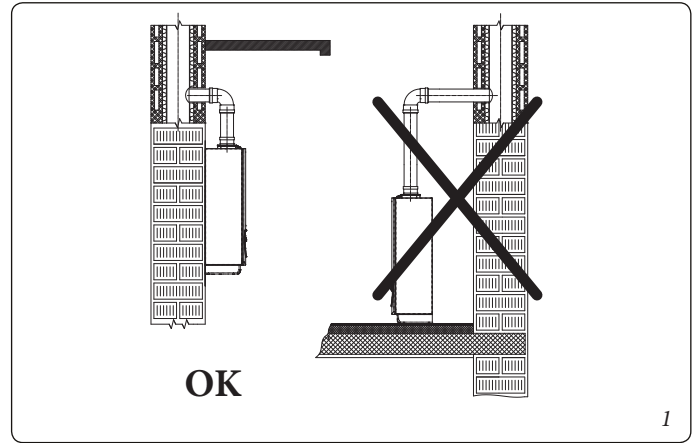

The Victrix Zeus 25-32 boiler has been designed for wall mounted installation only; for heating and production of domestic hot water for domestic use and similar purposes.



The place of installation of the appliance and relative Immergas accessories must have suitable features (technical and structural), such as to allow for (always in safe, efficient and comfortable conditions):

- installation (according to the provisions of technical legislation and technical regulations);
- maintenance operations (including scheduled, periodic, routine and special maintenance);
- removal (to outdoors in the place for loading and transporting the appliances and components) as well as the eventual replacement of those with appliances and/or equivalent components.

The wall surface must be smooth, without any protrusions or recesses enabling access to the rear part. They are not designed to be installed on plinths or floors (Fig. 1).

By varying the type of installation the classification of the boiler also varies, precisely:

- **Type B₂₃ or B₅₃** boiler if installed using the relevant terminal for air intake directly from the room in which the boiler has been installed.
- **Type C boiler** if installed using concentric pipes or other types of pipes envisioned for the sealed chamber boiler for intake of air and expulsion of flue gas.

Only professionally enabled companies are authorised to install Immergas gas appliances.

Installation must be carried out according to regulation standards, current legislation and in compliance with local technical regulations and the required technical procedures.

ATTENTION:

it is not permitted to install boilers that are removed and decommissioned from other systems. The manufacturer declines all liability for damages caused by boilers removed from other systems or for any non-conformities of such equipment.



ATTENTION:

check the environmental operating conditions of all parts relevant to installation, referring to the values shown in the technical data table in this booklet.



ATTENTION:

Installation of the Victrix Zeus 25-32 boiler when powered by LPG must comply with the rules regarding gases with a greater density than air (remember, as an example, that it is prohibited to install plants powered with the above-mentioned gas in rooms where the floor is at a lower quota than the country level).



ATTENTION:

if installing a kit or servicing the appliance, always empty the system's domestic hot water circuit first so as not to compromise the appliance's electrical safety (see Par. 2.9 and 2.10).



Before installing the appliance, ensure that it is delivered in perfect condition; if in doubt, contact the supplier immediately. Packing materials (staples, nails, plastic bags, polystyrene foam, etc.) constitute a hazard and must be kept out of the reach of children.

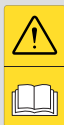

If the appliance is installed inside or between cabinets, ensure sufficient space for normal servicing; therefore it is advisable to leave clearance of at least 3 cm between the boiler casing and the vertical sides of the cabinet. Leave adequate space above the boiler for possible water and flue removal connections (Fig. 3).

It is just as important that the intake grids and exhaust terminals are not obstructed.

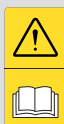

It is recommended to check that no flue gas recirculation is found in the air sample points (0.5% maximum permitted CO₂).

Keep all flammable objects away from the appliance (paper, rags, plastic, polystyrene, etc.).

The minimum distance for exhaust pipes from flammable materials must be at least 25 cm.

Do not place household appliances underneath the boiler as they could be damaged if the safety valve intervenes, if the drain trap is blocked, or if there are leaks from the hydraulic connections; otherwise, the manufacturer cannot be held responsible for any damage caused to the household appliances.

For the aforementioned reasons, we recommend not placing furnishings, furniture, etc. under the boiler.

In the event of malfunctions, faults or incorrect operation, turn the appliance off immediately and contact an authorised company (e.g. the Immergas Technical Assistance Centre, which has specifically trained staff and original spare parts). Do not attempt to modify or repair the appliance alone.

Any modification to the appliance that is not explicitly indicated in this section of the booklet is forbidden.

Installation Standards:

- **this boiler can be installed outdoors in a partially protected area. A partially protected area is one in which the boiler is not exposed to the direct action of the weather (rain, snow, hail, etc.).**



This type of installation is only possible when permitted by the laws in force in the appliance's country of destination.

- **Installation of gas appliances, flue exhaust pipes and combustion air intake pipes is forbidden in places with a fire risk (for example: garages, closed parking stalls), and in potentially dangerous places.**

- **Installation is prohibited on the vertical projection of the cooking surface.**



- **Installation is forbidden in places/rooms that constitute public areas of apartment buildings, internal stairways or other escape routes (e.g. floor landings, entrance halls, etc.).**

- **Installation is also forbidden in places/rooms that constitute public areas of apartment buildings such as cellars, entrance halls, attics, lofts, etc., unless otherwise provided for by local regulations in force.**

- **These boilers are not suitable for installation on walls made of combustible material.**

N.B.: wall mounting of the boiler must guarantee stable and efficient support for the boiler. The plugs (standard supply) are only to be used to fix the boiler to the wall; they only ensure adequate support if inserted correctly (according to technical standards) in walls made of solid or semi-hollow brick or block. In the case of walls made from hollow brick or block, partitions with limited static properties, or in any case walls other than those indicated, a static test must be carried out to ensure adequate support.



These boilers are used to heat water to below boiling temperature in atmospheric pressure. They must be connected to a central heating system and domestic hot water circuit suited to their performance and capacity.

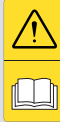

Risk of damage due to corrosion caused by unsuitable combustion air and environment.

Spray, solvents, chlorine-based detergents, paints, glue, ammonium compounds, powders and similar cause product and flue duct corrosion.



- Check that combustion air power supply is free from chlorine, sulphur, powders, etc.
- Make sure that no chemical substances are stored in the place of installation.
- If you want to install the product in beauty salons, paint workshops, carpenter's shop, cleaning companies or similar, choose a separate installation area that ensures combustion air supply that is free from chemical substances.
- Make sure the combustion air is not fed from chimneys that were used with gas boilers or other heating devices. In fact, these may cause an accumulation of soot in the chimney.

Risk of material damage after using sprays and liquids to search for leaks

Leak sprays and liquids clog the reference hole P.Ref (Part. 5 Fig. 38) of the gas valve, damaging it irreparably.

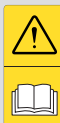

During installation and maintenance, do not use spray or liquids in the upper area of the gas valve (side referring to the electric connections).

Filling the condensate drain trap.

On first lighting of the boiler, flue gas may come out the condensate drain; after a few minutes' operation check that this no longer occurs. This means that the trap is filled with condensate to the correct level preventing the passage of combustion products.



ATTENTION:

- **Type B open chamber boilers must not be installed in places where commercial, artisan or industrial activities take place, which use products that may develop volatile vapours or substances (e.g. acid vapours, glues, paints, solvents, combustibles, etc.), as well as dusts (e.g. dust deriving from the working of wood, coal fines, cement, etc.), which may be damaging for the components of the appliance and jeopardise functioning.**
- **Unless otherwise provided for by local regulations in force, configurations B₂₃ and B₅₃: the boilers must not be installed in bedrooms, bathrooms or bedsits. They must neither be installed in rooms containing solid fuel heat generators nor in rooms communicating with said rooms.**
- **The installation rooms must be permanently ventilated, in compliance with the local regulations in force (at least 6 cm² for every kW of installed heat input, except in the event of any increases needed for electro-mechanical vacuum cleaners or other devices that could put the installation room under vacuum).**
- **Installation of appliances in B₂₃ and B₅₃ configuration is recommended in non-residential premises and which are permanently ventilated.**



ATTENTION:

Failure to comply with the above implies personal responsibility and invalidates the warranty.



1.2 MAIN DIMENSIONS.

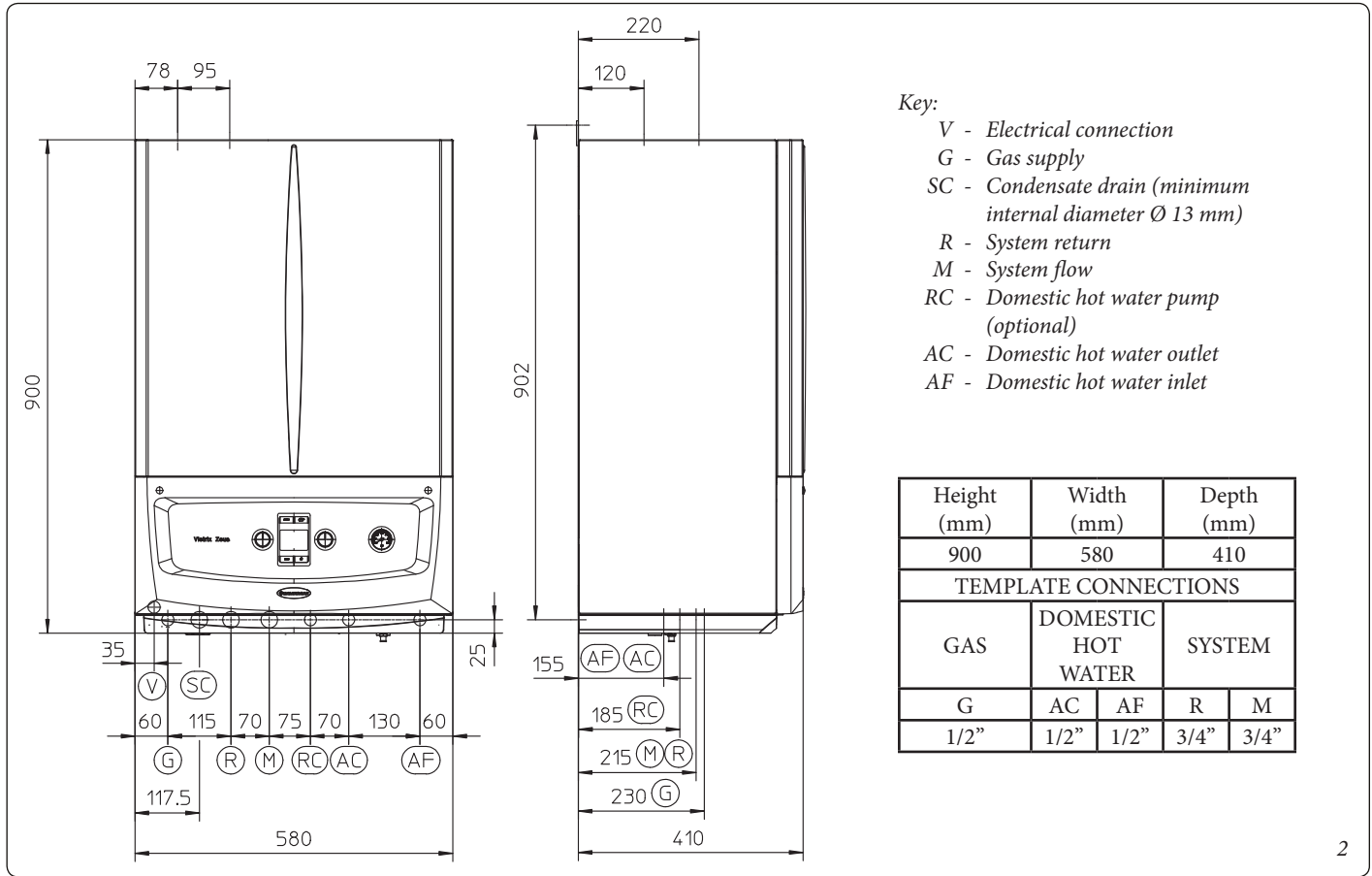

INSTALLER

USER

1.3 MINIMUM INSTALLATION DISTANCES.

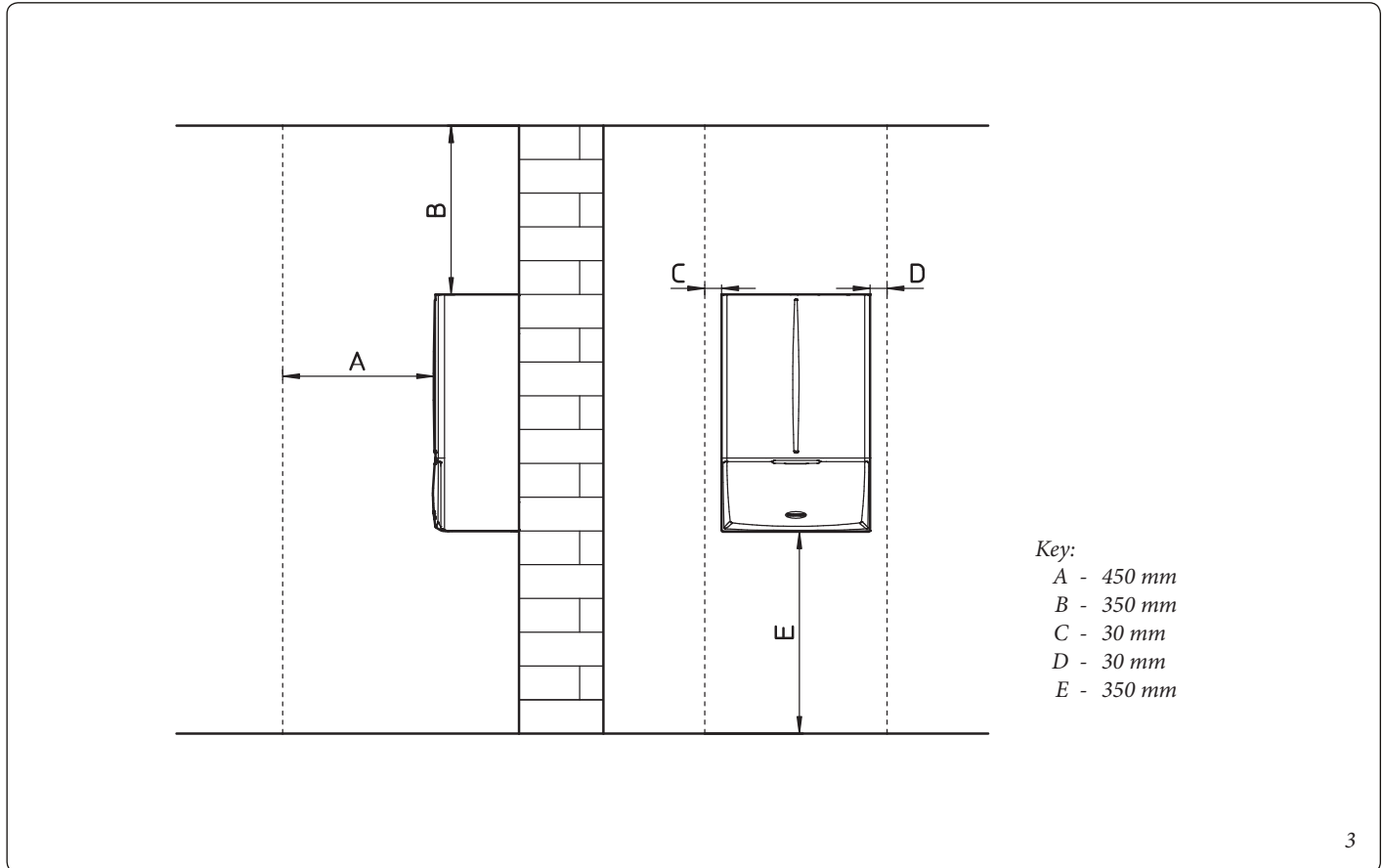

MAINTENANCE TECHNICIAN

1.4 ANTIFREEZE PROTECTION.

Minimum temperature -15°C. If the boiler is installed in a place where the temperature drops below 0°C, the appliance can freeze.

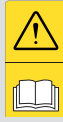

To prevent the risk of freezing follow the instructions below:

- protect the central heating circuit from freezing by inserting a good-quality antifreeze liquid into this circuit, which is specially suited for central heating systems and which is manufacturer guaranteed not to cause damage to the heat exchanger or other components of the boiler. The antifreeze liquid must not be harmful to one's health. The instructions of the manufacturer of this liquid must be followed scrupulously regarding the percentage necessary with respect to the minimum temperature at which the system must be kept.

N.B.: the excessive use of glycol could jeopardise the proper functioning of the appliance.

An aqueous solution must be made with potential pollution class of water 2 (EN 1717:2002).

The materials used for the central heating circuit of Immergas boilers resist ethylene and propylene glycol based antifreeze liquids (if the mixtures are prepared perfectly).

For life and possible disposal, follow the supplier's instructions.

- Protect the domestic hot water circuit against freezing by using an accessory that is supplied on request (antifreeze kit) comprising two electric heating elements, the relevant wiring and a control thermostat (carefully read the installation instructions contained in the accessory kit pack).

In these conditions the boiler is protected against freezing to temperature of -15°C.

Boiler antifreeze protection (both -5°C and -15°C) is thus ensured only if:

- the boiler is correctly connected to gas and electricity power supply circuits;
- the boiler is powered constantly;
- the boiler is not in "off" mode;
- the boiler is not in anomaly conditions (Par. 2.5);
- the essential components of the boiler and/or antifreeze kit are not faulty.

The warranty does not cover damage due to interruption of the electrical power supply and failure to comply with that stated on the previous page.

Note: if the boiler is installed in places where the temperature falls below 0°C the domestic hot water and central heating attachment pipes and the condensate drain pipe must be insulated.

Note: the antifreeze systems described in this chapter are only to protect the boiler. The presence of these functions and devices does not exclude the possibility of parts of the system or domestic hot water circuit outside the boiler from freezing.

1.5 BOILER CONNECTION UNIT.

The connection unit consisting of all the necessary parts to perform the hydraulic and gas system connections of the appliance comes as a standard supply. Perform the connections respecting the layout of (Fig. 4) based on the type of installation to be made.

1.6 GAS CONNECTION.

Our boilers are designed to operate with methane gas (G20) and L.P.G. Supply pipes must be the same as or larger than the 3/4" G boiler fitting.

ATTENTION:

Before connecting the gas line, carefully clean inside all the fuel feed system pipes to remove any residue that could impair boiler efficiency. Also make sure the gas corresponds to that for which the boiler is prepared (see boiler data nameplate). If different, the boiler must be converted for operation with the other type of gas (see converting appliance for other gas types). It is also important to check the dynamic pressure of the mains (methane or LPG) used to supply the boiler, which must comply with EN 437 and its attachment, as insufficient levels may reduce generator output and cause discomfort to the user.



According to local regulations in force, make sure that a gas cock is installed upstream of each connection between the appliance and the gas system. This cock, if supplied by the appliance's manufacturer, can be directly connected to the appliance (i.e. downstream from the pipes connecting the system to the appliance), according to the manufacturer's instructions.

The Immergas connection unit, which is a standard supply, also includes the gas cock, whose installation instructions are provided in the kit.

In any case, make sure the gas cock is connected properly.



The gas supply pipe must be suitably dimensioned according to current regulations in order to guarantee correct gas flow rate to the burner even in conditions of maximum generator output and to guarantee appliance efficiency (technical specifications). The coupling system must conform to standards in force (EN 1775).

ATTENTION:

the appliance is designed to operate with fuel gas free from impurities; otherwise it is advisable to fit special filters upstream of the appliance to restore the purity of the fuel.



INSTALLER

USER

MAINTENANCE TECHNICIAN

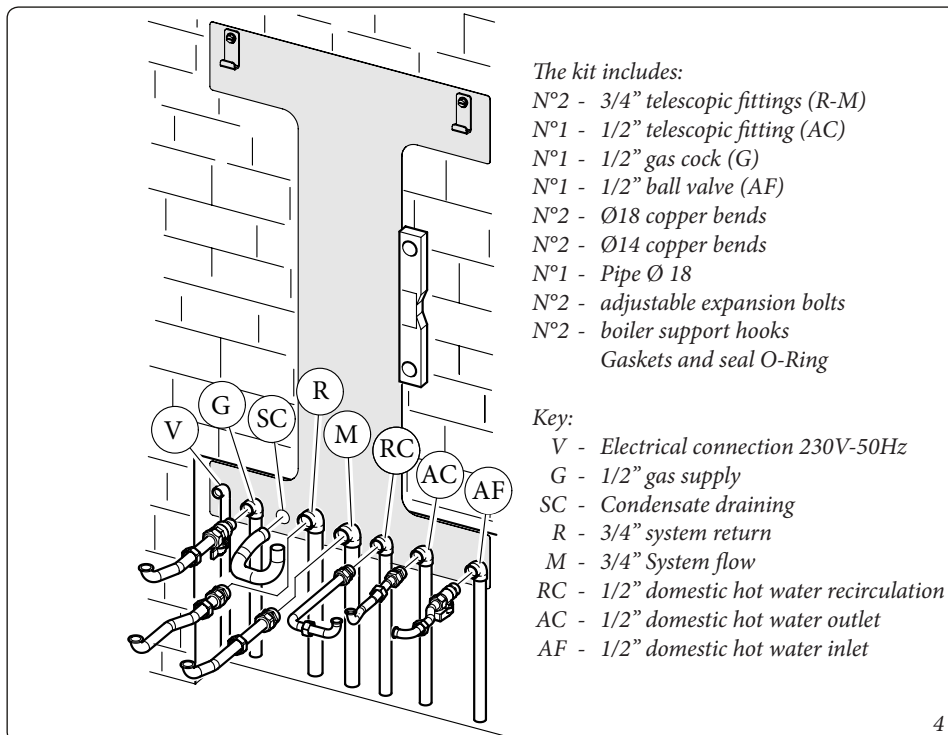

4

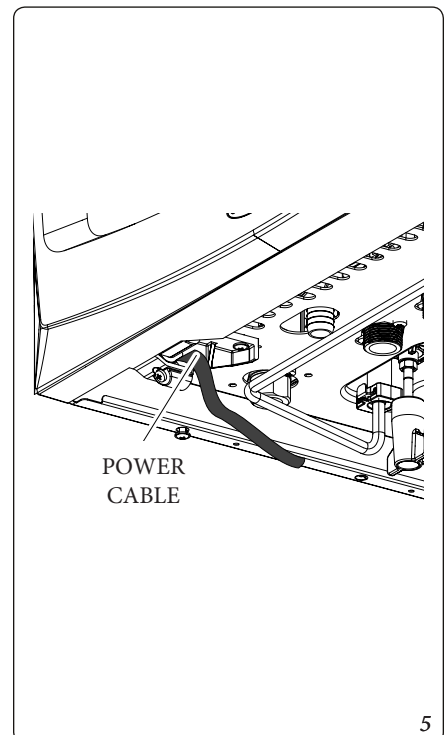

5

Storage tanks (in case of supply from LPG depot).

- New LPG storage tanks may contain residual inert gases (nitrogen) that degrade the mixture delivered to the appliance causing functioning anomalies.
- Due to the composition of the LPG mixture, layering of the mixture components may occur during the period of storage in the tanks. This can cause a variation in the calorific value of the mixture delivered to the appliance, with subsequent change in its performance.

1.7 HYDRAULIC CONNECTION.

In order not to void the condensation module warranty before making the boiler connections, carefully clean the heating system (pipes, radiators, etc.) with special pickling or descaling products to remove any deposits that could compromise correct boiler operation.



A treatment of the heating and water system water is required, in compliance with the technical standards in force, in order to protect the system and the appliance from deposits (e.g. scale), slurry or other hazardous deposits. In order not to void the heat exchanger warranty, you are required to comply with what has been prescribed in (Par. 1.22).

Water connections must be made in a rational way using the couplings on the boiler template.

ATTENTION:

the manufacturer declines all liability in the event of damage caused by the installation of an automatic filling system. 

In order to meet the system requirements established by EN 1717 in terms of pollution of drinking water, we recommend installing the IMMERGAS anti-backflow kit to be used upstream of the cold water inlet connection of the boiler. We also recommend using a category 1, 2 or 3 heat transfer fluid (ex: water + glycol) in the boiler's primary circuit (C.H. circuit), as defined in standard EN 1717.

To preserve the duration of appliance efficiency features, in the presence of water whose features can lead to the deposit of lime scale, installation of the "polyphosphate dispenser" kit is recommended .

**3 bar safety valve.**

Safety valve (Part. 5 Fig. 32) discharge must always be conveyed through a draining funnel. Consequently, in the event of valve intervention, the discharged liquid will end up in the sewer system.

Condensate drain.

To drain the condensate produced by the appliance, it is necessary to connect to the drainage system by means of acid condensate resistant pipes, with an internal Ø of at least 13 mm. The system connecting the appliance to the drainage system must be carried out in such a way as to prevent occlusion and freezing of the liquid contained in it. Before appliance ignition, ensure that the condensate can be correctly removed. After first ignition, check that the drain trap is filled with condensate (Para. 1.24). Also, comply with national and local regulations on discharging waste waters.

In the event condensate is not discharged into the wastewater drainage system, a condensate neutraliser must be installed to ensure compliance with the parameters established by the legislation in force.

1.8 ELECTRICAL CONNECTION.

The appliance has an IPX5D protection degree; electrical safety of the appliance is achieved only when it is connected properly to an efficient earthing system, as specified by current safety standards.

ATTENTION:

the manufacturer declines any responsibility for damage or physical injury caused by failure to connect the boiler to an efficient earthing system or failure to comply with the IEC reference standards.



• Open the control panel connections compartment (Fig. 6).

To carry out electrical connections, all you have to do is open the connections compartment as follows.

- Remove the front panel (Fig. 50).
- Remove the cover (Ref. b Fig. 6).
 - 1) Loosen the two screws (a).
 - 2) Press the two hooks on the cover (b).
 - 3) Remove the cover (b) from the control panel (c).
- At this point, it is possible to access the terminal board (d).

Also ensure that the electrical installation corresponds to maximum absorbed power specifications as shown on the boiler data nameplate. Boilers are supplied complete with an “X” type power cable without plug.

ATTENTION:

The power supply cable must be connected to a 230V ±10% / 50Hz mains supply respecting L-N polarity and earth connection; this network must also have a multi-pole circuit breaker with class III overvoltage category in compliance with installation regulations.



To protect from possible dispersions of DC voltage, it is necessary to provide a type A differential safety device.

If the power supply cable is damaged, it must be replaced by a special cable or assembly, which are only available from the manufacturer or its After-sales Service. It is recommended to contact a qualified company (e.g. the Immergas Authorised After-Sales Technical Assistance Service) for replacement to avoid a hazard. The power cable must be laid as shown (Fig. 5).

If the network fuse on the integrated P.C.B. needs replacing, this must also be done by qualified personnel: use a 3.15 A F (fast) 250 V fuse (size 5 x 20).

For the main power supply to the appliance, never use adapters, multiple sockets or extension leads.

Installation with system operating at direct low temperature.

The boiler can directly supply a low-temperature system by setting the flow temperature adjustment range “t0” and “t1” (Par. 3.15). In this situation it is good practice to insert a relevant safety kit (optional) made up from a thermostat (with adjustable temperature). Execute connection to terminal boards 14 and 15, eliminating jumper X70 (Fig. 36-37). The thermostat must be positioned on the system flow pipe at a distance of at least 2 metres from the boiler.

1.9 REMOTE CONTROLS AND ROOM CHRONOTHERMOSTATS (OPTIONAL).

The boiler is prepared for the application of room chronothermostats or remote controls, which are available as optional kits (Fig. 7).

All Immergas chrono-thermostats are connected with 2 wires only. Carefully read the user and assembly instructions contained in the accessory kit.

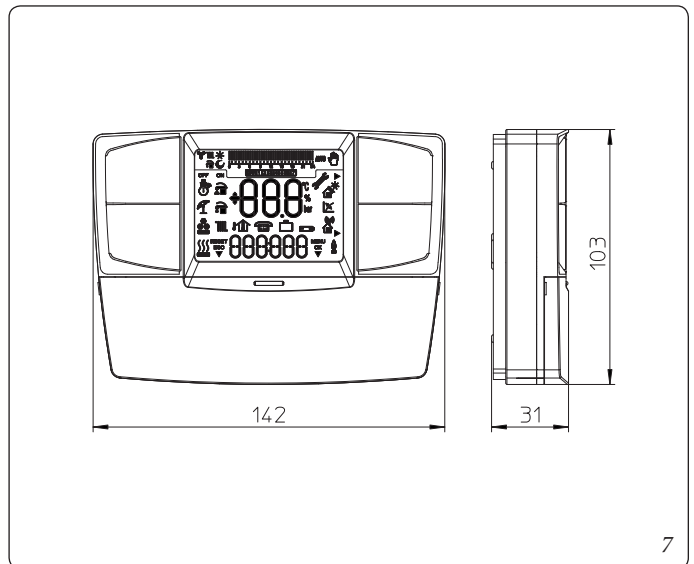
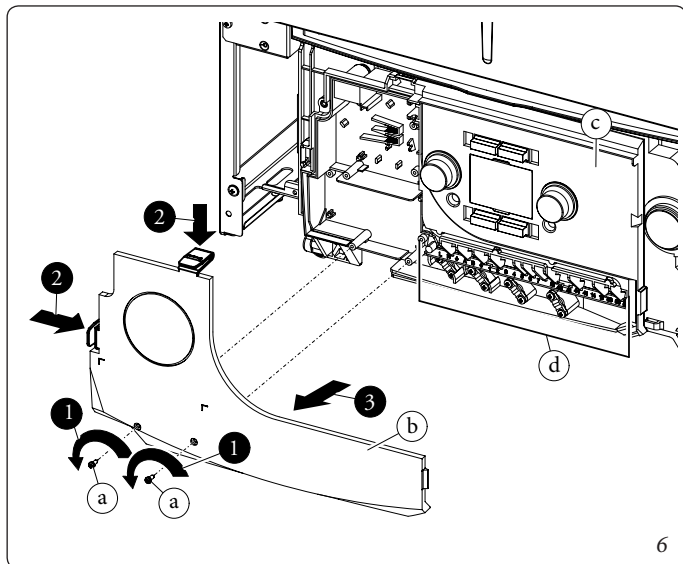

ATTENTION:
disconnect power to the appliance before any electrical connection.



• On/Off Immergas digital chrono-thermostat.

The chrono-thermostat allows:

- set two room temperature value: one for day (comfort temperature) and one for night (reduced temperature);
- set a weekly programme with four daily switch on and switch off times;
- selecting the required function mode from the various possible alternatives:
 - manual mode (with adjustable temperature).
 - automatic mode (with set programme).
 - forced automatic mode (momentarily changing the temperature of the automatic programme).

The chrono-thermostat is powered by two 1.5V LR 6 type alkaline batteries;

• Comando Amico Remoto Remote Control Device ^{v2} (CAR^{v2}) with climate chrono-thermostat function.

In addition to the functions described in the previous point, the CAR^{v2} panel enables the user to control all the important information regarding operation of the appliance and the heating system with the opportunity to easily intervene on the previously set parameters, without having to go to where the appliance is installed. The panel is provided with self-diagnosis to display any boiler functioning anomalies. The climate chrono-thermostat incorporated into the remote panel enables the system flow temperature to be adjusted to the actual needs of the room being heated, in order to obtain the desired room temperature with extreme precision and therefore with evident saving in running costs. The CAR^{v2} is fed directly by the boiler by means of the same 2 wires used for the transmission of data between the boiler and device.

If the system is divided into zones using the relevant kit, the CAR^{v2} must be used with its climate thermostat function disabled, i.e. it must be set to On/Off mode.



Comando Amico Remoto Remote Control V2 or On/Off chrono-thermostat electrical connections (Optional). The operations described below must be performed after having removed the voltage from the appliance. Any thermostat or On/Off environment chrono-thermostat must be connected to clamps 40 and 41 eliminating jumper X40 (Fig. 36-37). Make sure that the On/Off thermostat contact is of the “clean” type, i.e. independent of the mains voltage, otherwise the P.C.B. would be damaged. Any Comando Amico Remoto remote control V2 must be connected to terminals 44 and 41, eliminating jumper X40 on the P.C.B. (Fig. 36-37).

If the Comando Amico Remoto remote control ^{v2} or any other On/Off chrono-thermostat is used arrange two separate lines in compliance with current regulations regarding electrical systems. No boiler pipes must ever be used to earth the electric system or telephone lines. Ensure elimination of this risk before making the boiler electrical connections.



1.10 EXTERNAL TEMPERATURE PROBE (OPTIONAL).

The boiler is designed for the application of the external temperature probe (Fig. 8), which is available as an optional kit. Refer to the relative instruction sheet for positioning of the external probe. The probe can be connected directly to the boiler electrical system and allows the max. system flow temperature to be automatically decreased when the external temperature increases, in order to adjust the heat supplied to the system according to the change in external temperature. The external probe always operates when connected, regardless of the presence or type of room chrono-thermostat used and can work in combination with Immergas chrono-thermostats. The correlation between system flow temperature and external temperature is determined by the position of the central heating selector switch on the boiler control panel (or on the CAR^{v2} control panel if connected to the boiler) according to the curves shown in the diagram (Fig. 9). The electric connection of the external probe must be made on clamps 38 and 39 on the terminal board in the boiler control panel (Fig. 36-37).

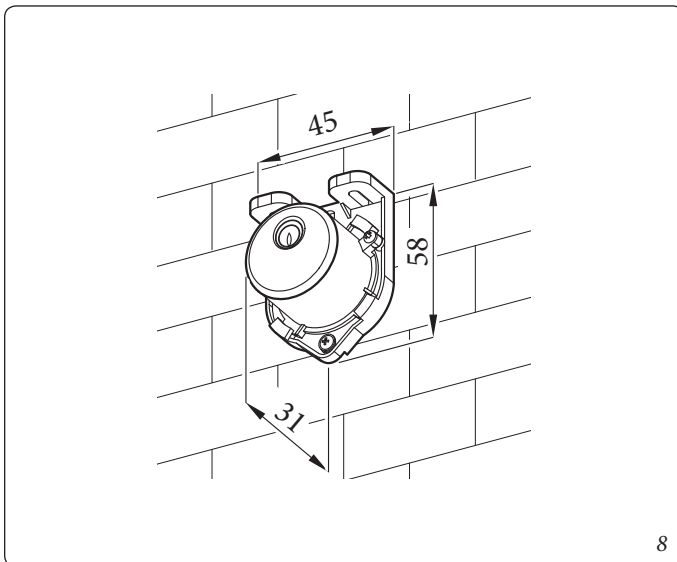

8

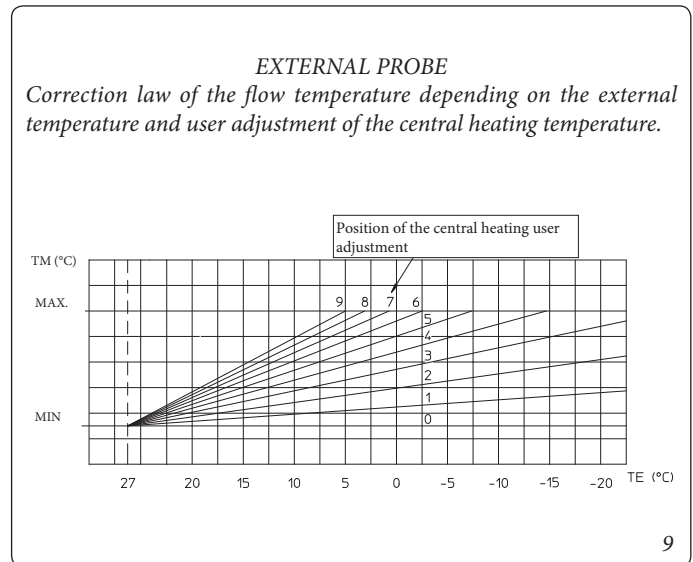

9

1.11 IMMERGAS FLUE SYSTEMS.

Immergas supplies various solutions separately from the boilers regarding the installation of air intake terminals and flue exhaust, which are fundamental for boiler operation.

ATTENTION:



the boiler must be installed exclusively with an original Immergas “Green Range” inspectionable air intake system and flue gas extraction system made of plastic, with the exception of the C6 configuration, as required by the regulations in force and by the product’s approval.

This flue can be identified by an identification mark and special distinctive marking bearing the note "only for condensation boilers".

The plastic pipes cannot be installed outdoors, for tracts longer than 40 cm, without suitable protection from UV rays and other atmospheric agents.

• Resistance factors and equivalent lengths.

Each flue component has a *Resistance Factor* based on experimental tests and specified in the table below. The Resistance Factor for individual components is independent from the type of boiler on which it is installed and has a dimensionless size. It is however, conditioned by the temperature of the fluids that pass through the pipe and therefore, varies according to applications for air intake or flue exhaust. Each single component has a resistance corresponding to a certain length in metres of pipe of the same diameter; the so-called *equivalent length*, can be obtained from the ratio between the relative Resistance Factors.

All boilers have an experimentally obtainable maximum Resistance Factor equal to 100.

The maximum Resistance Factor allowed corresponds to the resistance encountered with the maximum allowed pipe length for each type of Terminal Kit. This information allows calculations to be made to verify the possibility of setting up various flue configurations.

Note: to dimension the flue ducting using commercial components, refer to the table of combustion parameters (Paragraph 4.2).

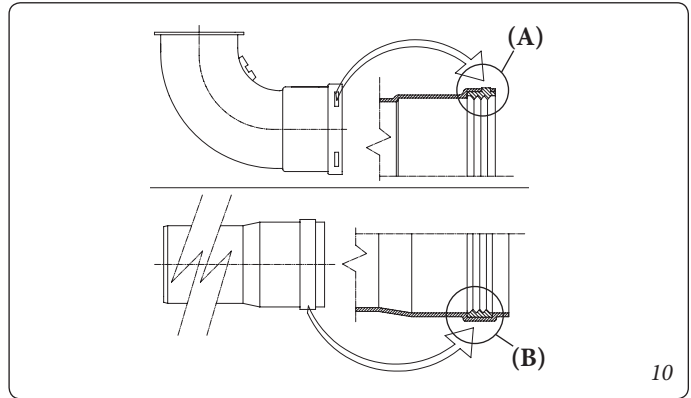

10

• Positioning the gaskets (black) for “green range” flue systems.

Position the gasket correctly (for bends and extensions) (Fig. 10):

- gasket (A) with notches, to use for bends;
- gasket (B) without notches, to use for extensions.

N.B.: if necessary, to ease the push-fitting, spread the elements with commonly-used talc.

• Extension pipes and concentric elbows push-fittings.

To install push-fitting extensions with other elements of the flue extraction elements assembly, proceed as follows: Install the concentric pipe or elbow with the male side (smooth) on the female side (with lip seal) to the end stop on the previously installed element in order to ensure sealing efficiency of the coupling.

N.B.: if the exhaust terminal and/or extension concentric pipe needs shortening, consider that the internal duct must always protrude by 5 mm with respect to the external duct.





N.B.: for safety purposes, do not obstruct the boiler intake/exhaust terminal, even temporarily.





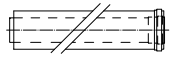

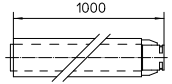
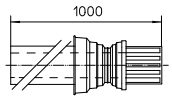

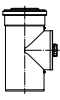

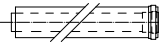

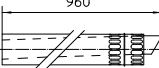
The various parts of the flue system must be checked to ensure that they have been laid in such a way as to prevent the coupled parts from detaching, in particular, the flue exhaust duct in the Ø80 separator kit configuration. Should the aforesaid condition not be adequately guaranteed, it will be necessary to use the special clamp ring nut clip kit.

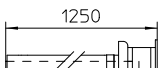

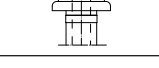
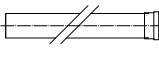
N.B.: when installing horizontal pipes, a minimum inclination of 3% towards the boiler must be maintained, and a section clip with pin must be installed every 3 metres.

1.12 TABLES OF RESISTANCE FACTORS AND EQUIVALENT LENGTHS OF “GREEN RANGE” FLUE SYSTEM COMPONENTS.

TYPE OF DUCT		Resistance Factor (R)	Length in m of concentric pipe Ø 80/125
Concentric pipe 80/125 Ø m 1		2.1	1
90° concentric bend Ø 80/125		3.0	1.4
Concentric bend 45° Ø 80/125		2.1	1
Terminal complete with concentric horizontal intake-exhaust Ø 80/125		2.8	1.3
Terminal complete with concentric vertical intake-exhaust Ø 80/125		3.6	1.7
90° concentric bend Ø 80/125 with inspection		3.4	1.6
Stub pipe with inspection Ø 80/125		3.4	1.6

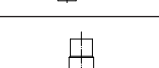
TYPE OF DUCT		Resistance Factor (R)	Length in m of concentric pipe Ø 60/100	Length in metres of a Ø 80 pipe	Length in metres of a Ø 60 pipe	Length in m of concentric pipe Ø 80/125
Concentric pipe Ø 60/100 m 1		Intake and Exhaust 6.4	m 1	Intake m 7.3	Exhaust m 1.9	m 3.0
				Exhaust m 5.3		
90° concentric bend Ø 60/100		Intake and Exhaust 8.2	m 1.3	Intake m 9.4	Exhaust m 2.5	m 3.9
				Exhaust m 6.8		
Concentric bend 45° Ø 60/100		Intake and Exhaust 6.4	m 1	Intake m 7.3	Exhaust m 1.9	m 3.0
				Exhaust m 5.3		
Terminal complete with concentric horizontal intake-exhaust Ø 60/100		Intake and Exhaust 15	m 2.3	Intake m 17.2	Exhaust m 4.5	m 7.1
				Exhaust m 12.5		
Concentric horizontal intake-exhaust terminal Ø 60/100		Intake and Exhaust 10	m 1.5	Intake m 11.5	Exhaust m 3.0	4.7 m
				Exhaust m 8.3		
Terminal complete with concentric vertical intake-exhaust Ø 60/100		Intake and Exhaust 16.3	m 2.5	Intake m 18.7	Exhaust m 4.9	m 7.7
				Exhaust m 13.6		
Concentric vertical intake-exhaust terminal Ø 60/100		Intake and Exhaust 9	1.4 m	Intake m 10.3	Exhaust m 2.7	m 4.3
				Exhaust m 7.5		
Pipe Ø 80 m 1		Intake 0.87	m 0.1	Intake m 1.0	Exhaust m 0.4	m 0.4
		Exhaust 1.2	m 0.2	Exhaust m 1.0		m 0.5
Complete intake terminal Ø 80 m 1		Intake 3	m 0.5	Intake m 3.4	Exhaust m 0.9	1.4 m
Intake terminal Ø 80 Exhaust terminal Ø 80		Intake 2.2	m 0.35	Intake m 2.5	Exhaust m 0.6	m 1
		Exhaust 1.9	m 0.3	Exhaust m 1.6		m 0.9
Bend 90° Ø 80		Intake 1.9	m 0.3	Intake m 2.2	Exhaust m 0.8	m 0.9
		Exhaust 2.6	m 0.4	Exhaust m 2.1		m 1.2
Bend 45° Ø 80		Intake 1.2	m 0.2	Intake m 1.4	Exhaust m 0.5	m 0.5
		Exhaust 1.6	m 0.25	Exhaust m 1.3		0.7
Pipe Ø 60 m 1 for ducting		Exhaust 3.3	m 0.5	Intake 3.8	Exhaust m 1.0	m 1.5
				Exhaust 2.7		
Bend 90° Ø 60 for ducting		Exhaust 3.5	m 0.55	Intake 4.0	Exhaust m 1.1	m 1.6
				Exhaust 2.9		
Reduction Ø 80/60		Intake and Exhaust 2.6	m 0.4	Intake m 3.0	Exhaust m 0.8	m 1.2
				Exhaust m 2.1		
Terminal complete with exhaust vertical Ø 60 for ducting		Exhaust 12.2	m 1.9	Intake m 14	Exhaust m 3.7	m 5.8
				Exhaust m 10.1		

INSTALLER

USER

MAINTENANCE TECHNICIAN

1.13 OUTDOOR INSTALLATION IN PARTIALLY PROTECTED AREA.

A partially protected location is a place where the appliance is not exposed to the direct effects of the weather (rain, snow, hail, etc.).



If the appliance is installed in a place where the ambient temperature drops below 0°C, use the optional antifreeze kit, checking the ambient operating temperature range shown in the technical data table in this instruction booklet.



Configuration type B, open chamber and fan assisted. (B₂₃ or B₅₃).

Using the special coverage kit one can achieve direct air intake (Fig. 11) and flue gas exhaust in a single chimney or directly outside. In this configuration it is possible to install the boiler in a partially protected place. In this configuration the boiler is classified as type B.

With this configuration:

- air intake takes place directly from the environment in which the appliance is installed (external);
- the flue gas exhaust must be connected to its own single chimney (B₂₃) or ducted directly outside via a vertical terminal for direct exhaust (B₅₃) or via an Immergas ducting system (B₅₃).

The technical regulations in force must be respected.

Kit assembly (Fig. 12).

By leaving the side plugs fitted it is possible to install the appliance externally without the cover kit. Installation takes place using the Ø60/100 and Ø 80/125 concentric intake/ exhaust kits. Refer to the paragraph on indoor installation. In this configuration the upper cover kit guarantees additional protection for the boiler. It is recommended but not compulsory. The Ø 80/80 separating device cannot be used in this configuration (coupled with the cover kit).

Max. length of exhaust duct.

The flue pipe (both vertical or horizontal) can be extended to a max. length of 30 linear metres.

Coupling of extension pipes.

To install push-fitting extensions with other elements of the flue, proceed as follows: Couple the pipe or elbow with the male side (smooth) in the female side (with lip seal) to the end stop on the previously installed element. This will ensure sealing efficiency of the coupling.

Configuration without cover kit in a partially protected location (type C boiler).

By leaving the side plugs fitted it is possible to install the appliance externally without the cover kit. Installation takes place using the Ø60/100 and Ø 80/125 concentric intake/ exhaust kits. Refer to the paragraph on indoor installation. In this configuration the upper cover kit guarantees additional protection for the boiler. It is recommended but not compulsory. The Ø 80/80 separating device cannot be used in this configuration (coupled with the cover kit).

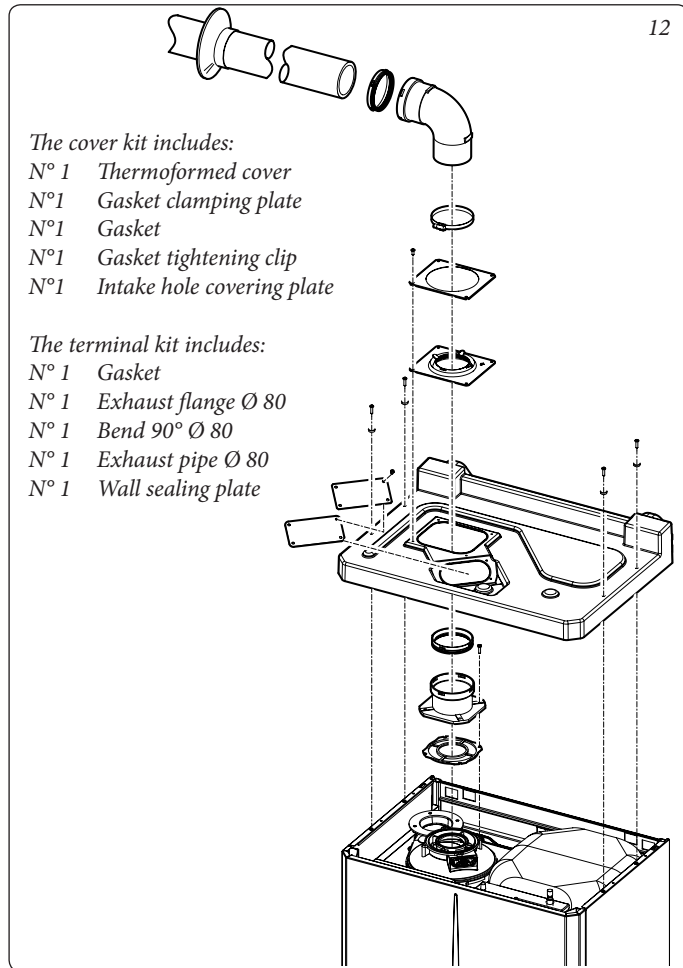
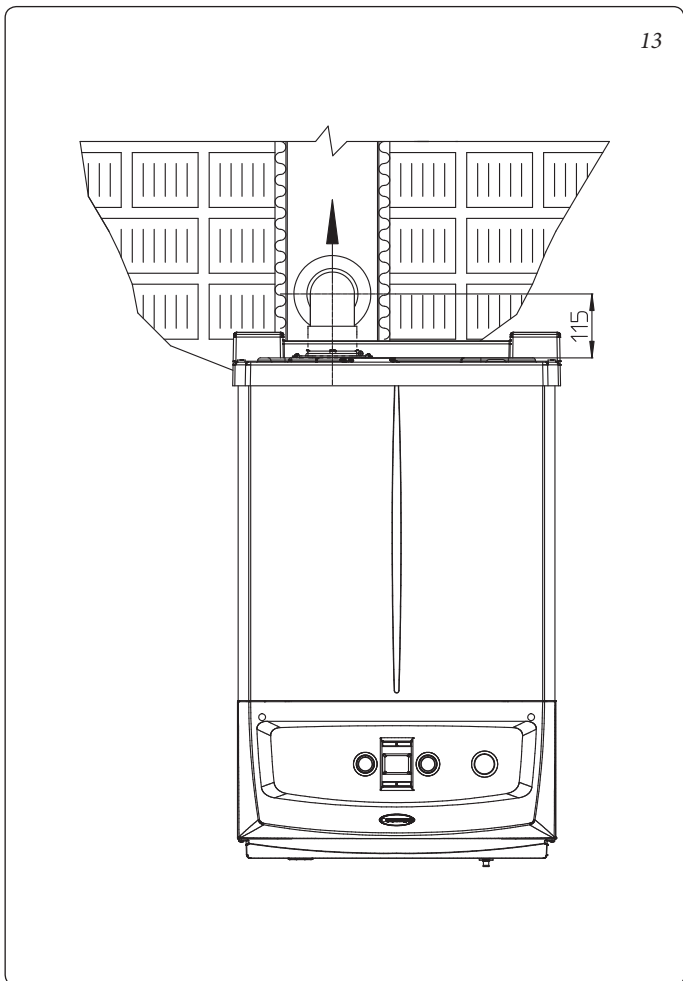
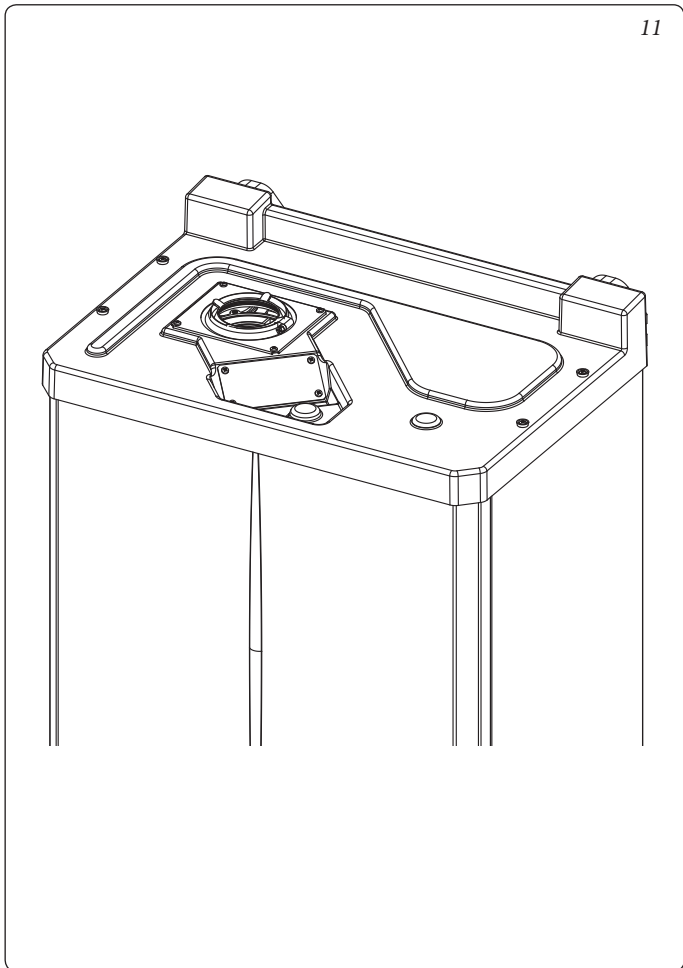

INSTALLER

USER

MAINTENANCE TECHNICIAN

1.14 CONCENTRIC HORIZONTAL KIT INSTALLATION.

• Type C configuration, sealed chamber and fan assisted.

The position of the terminal (in terms of distances from openings, overlooking buildings, floor, etc.) must be in compliance with the regulations in force.

This terminal is connected directly to the outside of the building for air intake and flue gas exhaust. The horizontal kit can be installed with the rear, right side, left side or front outlet. For installation with frontal outlet, one must use the fixing plate and a concentric bend coupling in order to ensure sufficient space to carry out the tests required by law upon commissioning.

• External grid.

Both the Ø 60/100 and Ø 80/125 intake/exhaust terminal, if properly installed, is pleasant to look at on the outside of the building. Make sure that the external silicone wall sealing plate is properly inserted in the wall.

ATTENTION:

for correct functioning of the system the terminal with grid must be installed correctly ensuring that, the "high" indication present on the terminal is respected on installation.



Horizontal intake-exhaust kit Ø 60/100. Kit Assembly

(Fig. 14):

install the bend with flange (2) on the central hole of the boiler, positioning gasket (1) with the circular projections downwards in contact with the boiler flange, and tighten using the screws present in the kit. Fit the Ø 60/100 (3) concentric terminal pipe with the male side (smooth) to the female side of the bend (2) up to the end stop; making sure that the internal and external wall sealing plate have been fitted, this will ensure sealing and joining of the elements making up the kit.

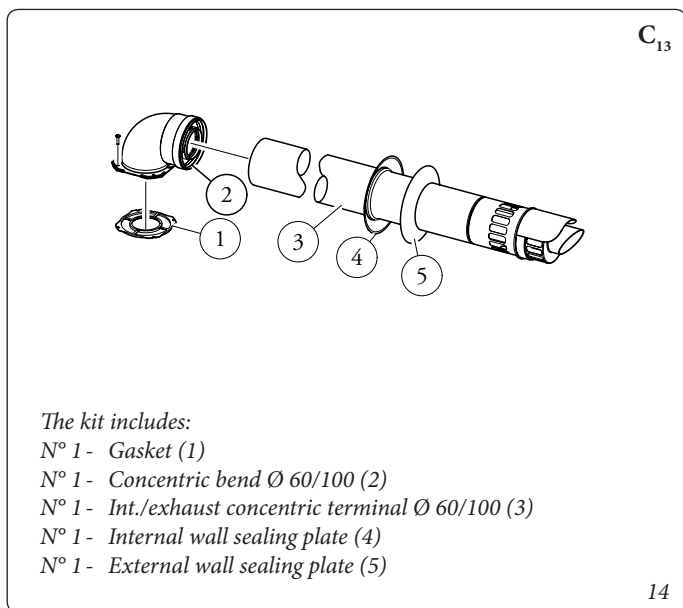

• Extensions for Ø 60/100 horizontal kit (Fig. 15).

The kit with this configuration can be extended up to a max. horizontal length of 12.9 m including the terminal with grid and excluding the concentric bend leaving the boiler. This configuration corresponds to a resistance factor of 100. In this case the special extensions must be requested.

Immergas also provides a Ø 60/100 simplified terminal, which in combination with its extension kits allows you to reach a maximum extension of 11.9 metres.

Horizontal intake-exhaust kit Ø 80/125. Kit Assembly

(Fig. 16):

to install the kit Ø 80/125 one must use the flanged adapter kit in order to install the flue system Ø 80/125. Install the flanged adaptor (2) on the central hole of the boiler, positioning gasket (1) with the circular projections downwards in contact with the boiler flange, and tighten using the screws contained in the kit. Engage the bend (3) with the male side (smooth) to the end stop on the adapter (1). Fit the Ø 80/125 (5) concentric terminal pipe with the male side (smooth) to the female side of the bend (4) (with lip seals) up to the end stop; making sure that the internal (6) and external wall sealing plate (7) have been fitted, this will ensure sealing and joining of the elements making up the kit.

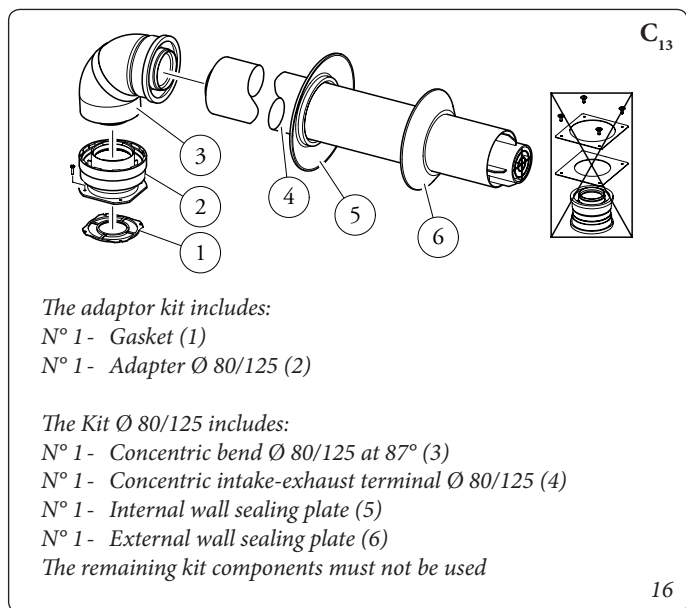
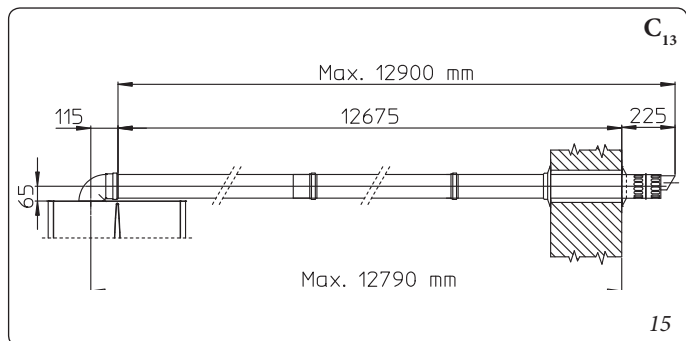

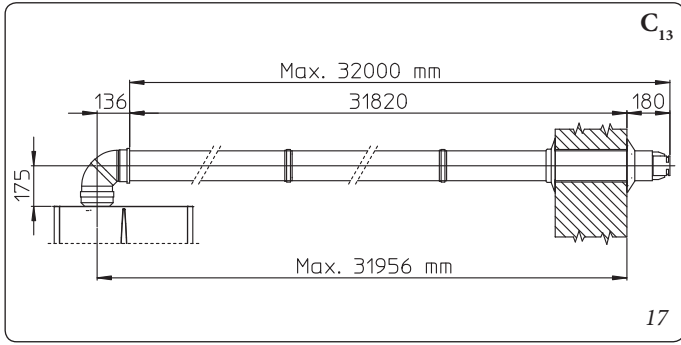

• **Extensions for Ø 80/125 horizontal kit (Fig. 17).**

The kit with this configuration can be extended up to a max. length of 32 m, including the terminal with grid and excluding the concentric bend leaving the boiler. If additional components are assembled, the length equivalent to the maximum allowed must be subtracted. In this case the special extensions must be requested.

1.15 CONCENTRIC VERTICAL KIT INSTALLATION.

• **Type C configuration, sealed chamber and fan assisted.**

Concentric vertical intake and exhaust kit. This vertical terminal is connected directly to the outside of the building for air intake and flue gas exhaust.

N.B.: the vertical kit with aluminium tile enables installation on terraces and roofs with a maximum slope of 45% (approx 25°) and the height between the terminal cap and half-shell (374 mm for Ø 60/100 and 260 mm for Ø 80/125) must always be observed.

Vertical kit with aluminium tile Ø 60/100.

Kit assembly (Fig. 18):

install the concentric flange (2) on the central hole of the boiler, positioning gasket (1) with the circular projections downwards in contact with the boiler flange, and tighten using the screws contained in the kit.

Installation of the fake aluminium tile: replace the tiles with the aluminium sheet (4), shaping it to ensure that rainwater runs off. Position the fixed half-shell (6) on the aluminium tile and insert the intake-exhaust pipe (5). Fit the Ø 60/100 concentric terminal pipe with the male side (5) (smooth) into the flange (2) up to the end stop; making sure that the wall sealing plate has been fitted (3), this will ensure sealing and joining of the elements making up the kit.

NOTE: when the boiler is installed in areas where very cold temperatures can be reached, a special anti-freeze kit is available that can be installed as an alternative to the standard kit.

• **Extensions for vertical kit Ø 60/100 (Fig. 19).**

The kit with this configuration can be extended to a max. straight vertical length of 14.4 m, including the terminal. This configuration corresponds to a resistance factor of 100. In this case specific extensions must be requested.

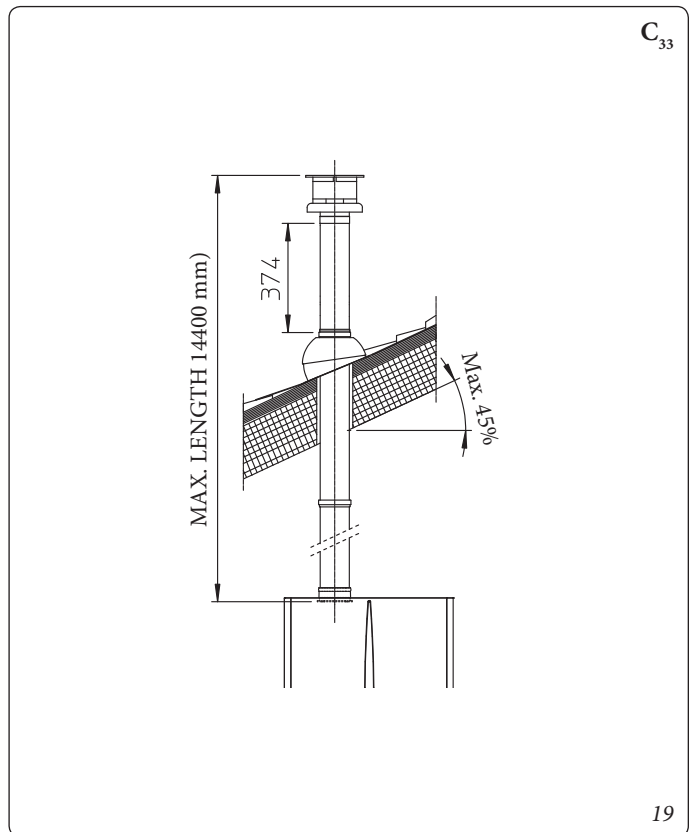
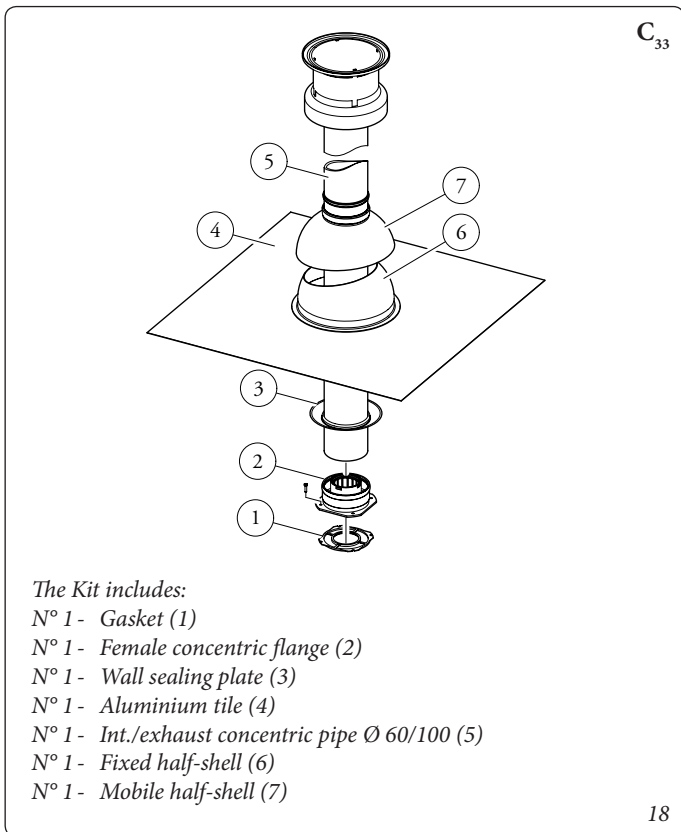

INSTALLER

USER

MAINTENANCE TECHNICIAN

Vertical kit with aluminium tile Ø 80/125.

Kit assembly (Fig. 20):

to install the kit Ø 80/125 one must use the flanged adapter kit in order to install the flue system Ø 80/125. Install the flanged adaptor (2) on the central hole of the boiler, positioning gasket (1) with the circular projections downwards in contact with the boiler flange, and tighten using the screws contained in the kit. Installation of the fake aluminium tile: replace the tiles with the aluminium sheet (4), shaping it to ensure that rainwater runs off. Position the fixed half-shell (5) on the aluminium tile and insert the intake-exhaust pipe (7). Fit the Ø 80/125 concentric terminal pipe with the male side (smooth) to the female side of the adapter (1) (with lip gaskets) up to the end stop; making sure that the wall sealing plate (3) has been fitted, this will ensure sealing and joining of the elements making up the kit.

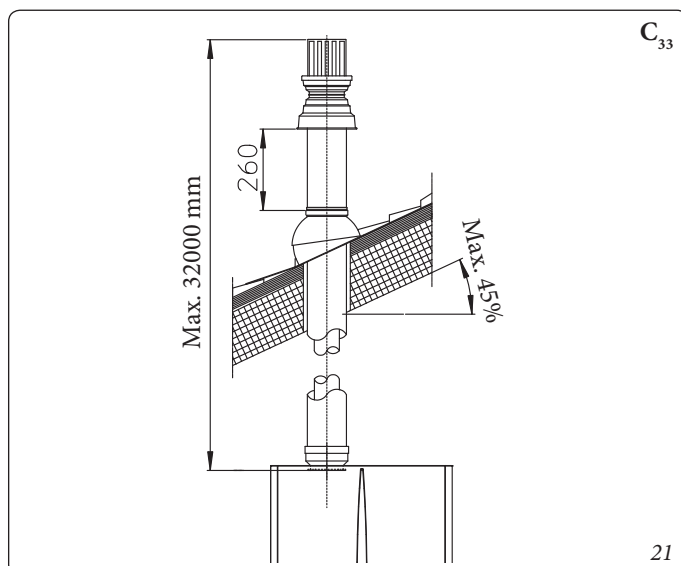
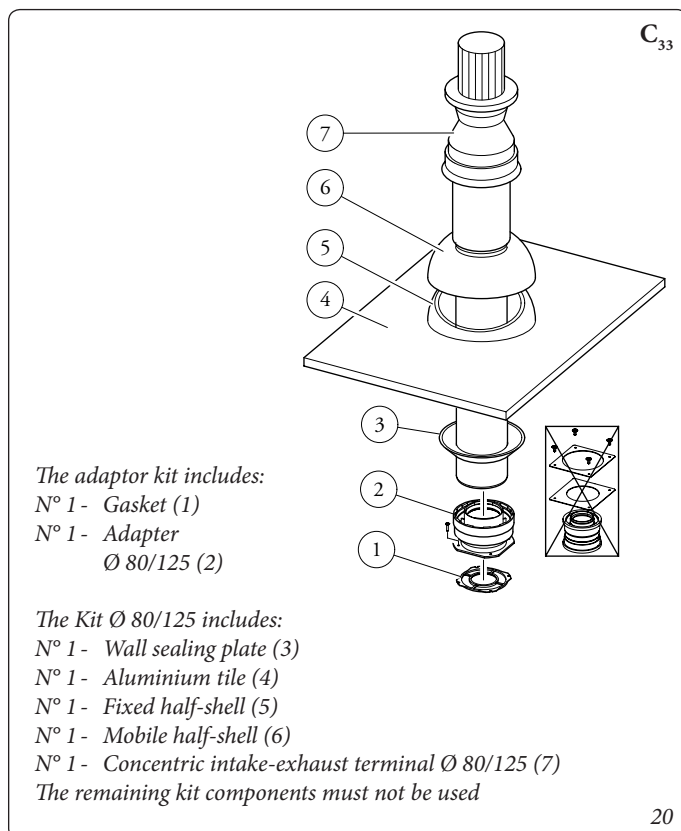

• Extensions for vertical kit Ø 80/125 (Fig. 21).

The kit with this configuration can be extended up to a max. length of 32 m including the terminal. If additional components are assembled, the length equivalent to the maximum allowed must be subtracted. In this case specific extensions must be requested.

1.16 SEPARATOR KIT INSTALLATION.

Type C configuration, sealed chamber and fan assisted.

• Separator kit Ø 80/80.

This kit allows air to come in from outside the building and the exhaust to exit from the chimney, flue or intubated duct through divided flue exhaust and air intake pipes. Combustion products are expelled from pipe (S) (in plastic, so as to resist acid condensate). Air is taken in through duct (A) for combustion (this is also in plastic). The intake pipe (A) can be installed either on the right or left hand side of the central exhaust pipe (S). Both ducts can be routed in any direction.

• Kit assembly (Fig. 22):

install flange (4) on the central hole of the boiler, positioning gasket (1) with the circular projections downwards in contact with the boiler flange, and tighten using the hex screws with flat tip contained in the kit. Remove the flat flange present in the lateral hole with respect to the central one (according to needs) and replace it with the flange (3), positioning the gasket (2) already present in the boiler and tighten using the supplied self-threading screws. Fit the male side (smooth) to the bends (5) in the female side of the flanges (3 and 4). Fit the intake terminal (6) with the male side (smooth) in the female side of the bend (5) up to the end stop, ensuring that the internal and external wall sealing plates are fitted. Fit the exhaust pipe (9) with the male end (smooth) to the female end of the bend (5) up to the

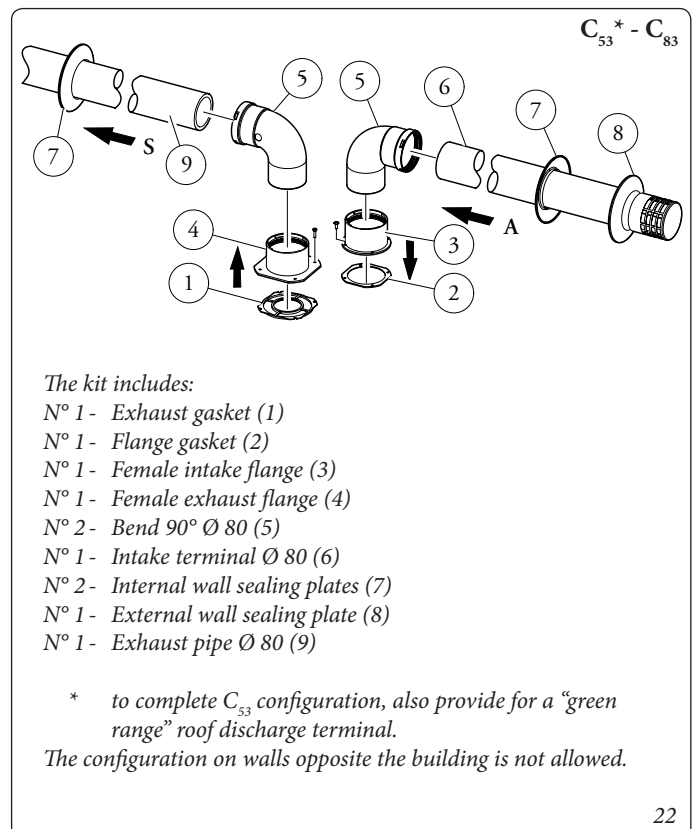

end stop; making sure that the internal wall sealing plate has been fitted, this will ensure sealing and joining of the elements making up the kit.

• **Installation clearances (Fig. 23).**

The minimum installation clearance measurements of the Ø 80/80 separator terminal kit have been stated in some limit conditions.

• **Extensions for separator kit Ø 80/80.**

The maximum vertical straight length (without bends) that can be used for Ø 80 intake and exhaust pipes is 41 metres, regardless from whether they are used for intake or exhaust. The maximum horizontal straight length (with bend in suction and in exhaust) that can be used for Ø 80 intake and exhaust pipes is 36 metres, regardless from whether they are used for intake or exhaust. Please note the type of installation C_{43} must be done with a natural draught flue.

N.B.: to favour the removal of possible condensate forming in the exhaust pipe, tilt the pipes towards the boiler with a minimum slope of 1.5% (Fig. 24).

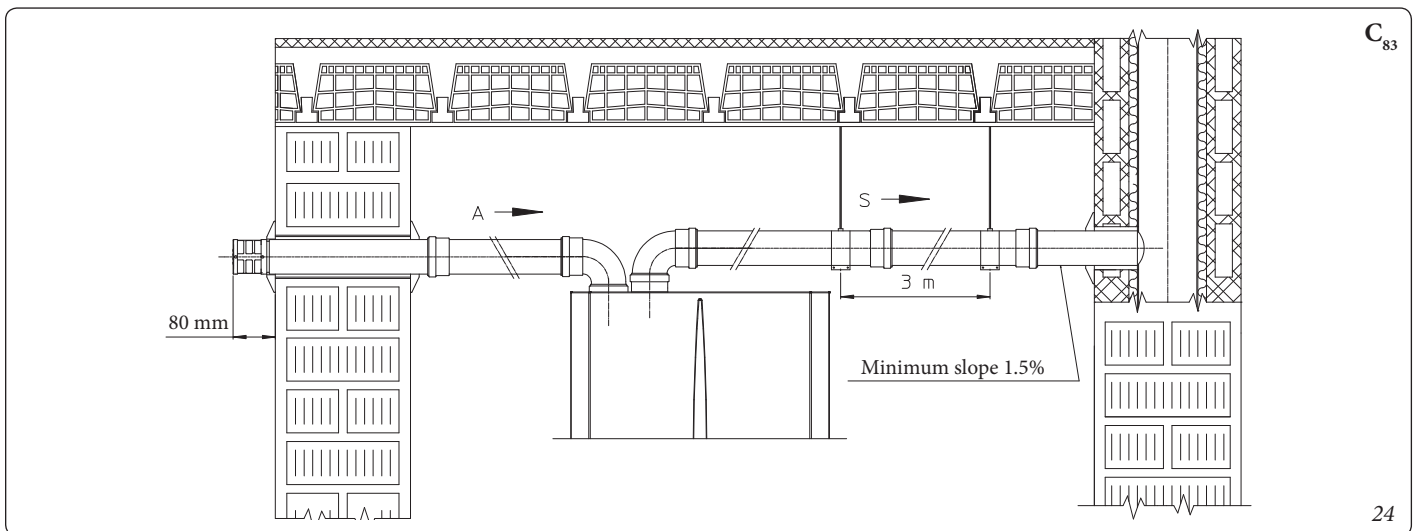
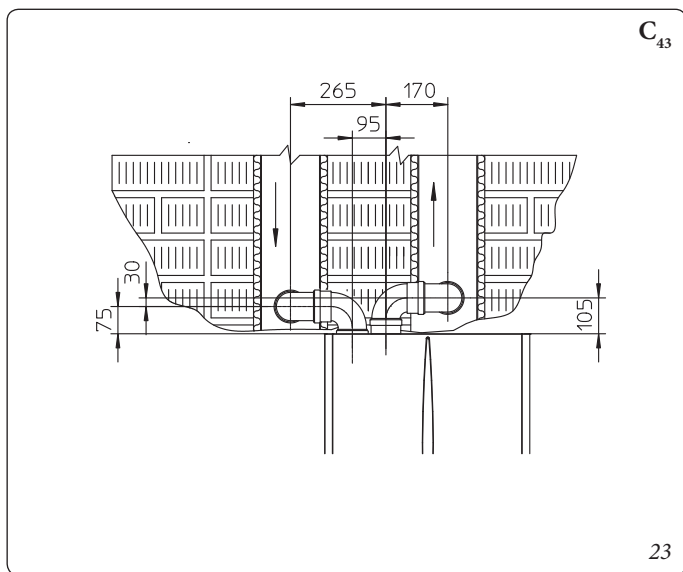

1.17 ADAPTOR C9 KIT INSTALLATION.

This kit allows an Immergas boiler to be installed in "C₉₃" configuration, with combustion air intake directly from the shaft where the flue gas exhaust is, obtained by means of a ducting system.

System composition.

The system must be combined with the following components (sold separately) to be functional and complete:

- kit C₉₃ Ø 100 or Ø125 version;
- rigid ducting Ø 60 and Ø 80 and flexible Ø 50 and Ø 80 kit;
- flue exhaust kit Ø 60/100 or Ø 80/125 configured according to the installation and type of boiler.

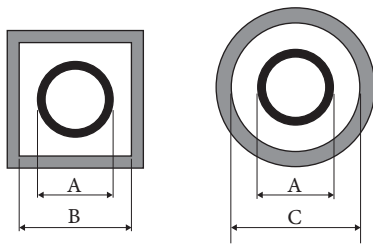

Ducting Ø 60 Rigid and Ø 50 Flexible (A) mm	SHAFT (B) mm	SHAFT (C) mm
66	106	126
Ducting Ø 80 Rigid (A) mm	SHAFT (B) mm	SHAFT (C) mm
86	126	146
Ducting Ø 80 Flexible (A) mm	SHAFT (B) mm	SHAFT (C) mm
90	130	150

25

Kit Assembly.

- Mount the components of kit "C9" on the door (A) of the ducting system (Fig. 26).
- (Version Ø 125 only) mount the flanged adaptor (11) interposing the concentric gasket (10) on the boiler, fitting it with the screws (12).
- Mount the ducting system as described in the relative instructions sheet.
- Calculate the distances between the boiler drain and the bend of the ducting system.
- Prepare the boiler flue system, making sure that the internal pipe of the concentric kit is fitted up to the end stop in the ducting system curve (Quota "X" Fig. 27), whereas the external pipe must reach the end stop of the adaptor (1).

N.B.: to encourage the removal of possible condensate forming in the exhaust pipe, tilt the pipes towards the boiler with a minimum slope of 1.5%.

- Mount the cover (A) complete with adaptor (1) and caps (6) on the wall and assemble the flue system to the ducting system.

N.B.: (version Ø 125 only) before assembly check the gaskets are in the right position. In the event component lubrication (already carried out by the manufacturer) is not sufficient, remove the residual lubricant using a dry cloth, then to ease fitting coat the parts with common or industrial talc.

Once all components have been assembled properly, the exhaust fumes will be expelled via the ducting system; the combustion air for normal boiler operation will be aspirated directly by the shaft (Fig. 27).

Kit composition:

Ref.	Qty	Description
1	1	Door adaptor Ø 100 or Ø 125
2	1	Door gasket made of neoprene
3	4	Screws 4.2 x 9 AF
4	1	Hex headed screw M6 x 20
5	1	Flat nylon washer M6
6	2	Door hole closure metal-sheet plate plug
7	1	Plug gasket made of neoprene
8	1	Toothed washer M6
9	1	Nut M6
10	1 (kit 80/125)	Concentric gasket Ø 60-100
11	1 (kit 80/125)	Flanged adaptor Ø 80-125
12	4 (kit 80/125)	Hex headed screws M4 x 16 slotted
-	1 (kit 80/125)	Bag of lubricating talc

Supplied separately:

Ref.	Qty	Description
A	1	Ducting kit door

Installation drawings key:

- ① Unique identification of the component in the kit
- A Identification of the component not supplied in this kit

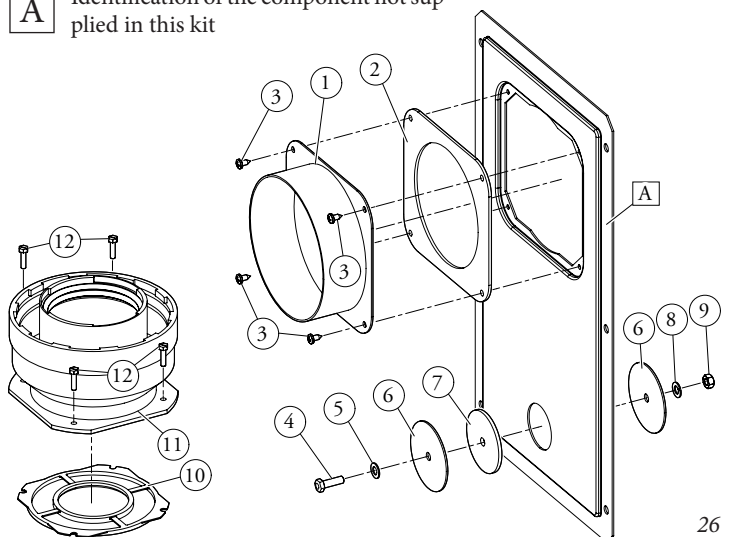

26

Technical data.

- The dimensions of the shafts must ensure a minimum gap between the outer wall of the smoke duct and the inner wall of the shaft: 30 mm for circular section shafts and 20 mm in the event of a square section shaft (Fig. 24).
- Maximum 2 changes of direction are allowed on the vertical section of the flue system with a maximum clearance angle of 30° with respect to the vertical.
- The maximum vertical extension using a Ø 60 ducting system is 13 m, the maximum extension includes 1 bend Ø 60/10 at 90°, 1 m of horizontal pipe 60/100, 1 90° ducted bend Ø 60 and the roof terminal for ducting.

To determine the C_{93} flue system in configurations other than that described (Fig. 26) one must consider that 1 metre of ducted pipe according to the indications described has a resistance factor equal to 4.9.

- The maximum vertical extension using a Ø 80 ducting system is 28 m, the maximum extension includes 1 adapter 60/100 to 80/125, 1 87° bend Ø 80/125, 1 m of horizontal pipe 80/125, 1 90° ducted bend Ø 80 and the roof terminal for ducting.

To determine the C_{93} flue system in configurations other than that described (Fig. 26) one must consider the following head losses:

- 1 m of concentric pipe Ø 80/125 = 1 m of ducted pipe;
- 1 87° bend = 1.4 m of ducted pipe;

Consequently one must subtract the equivalent length of the part added to the 28 m available.

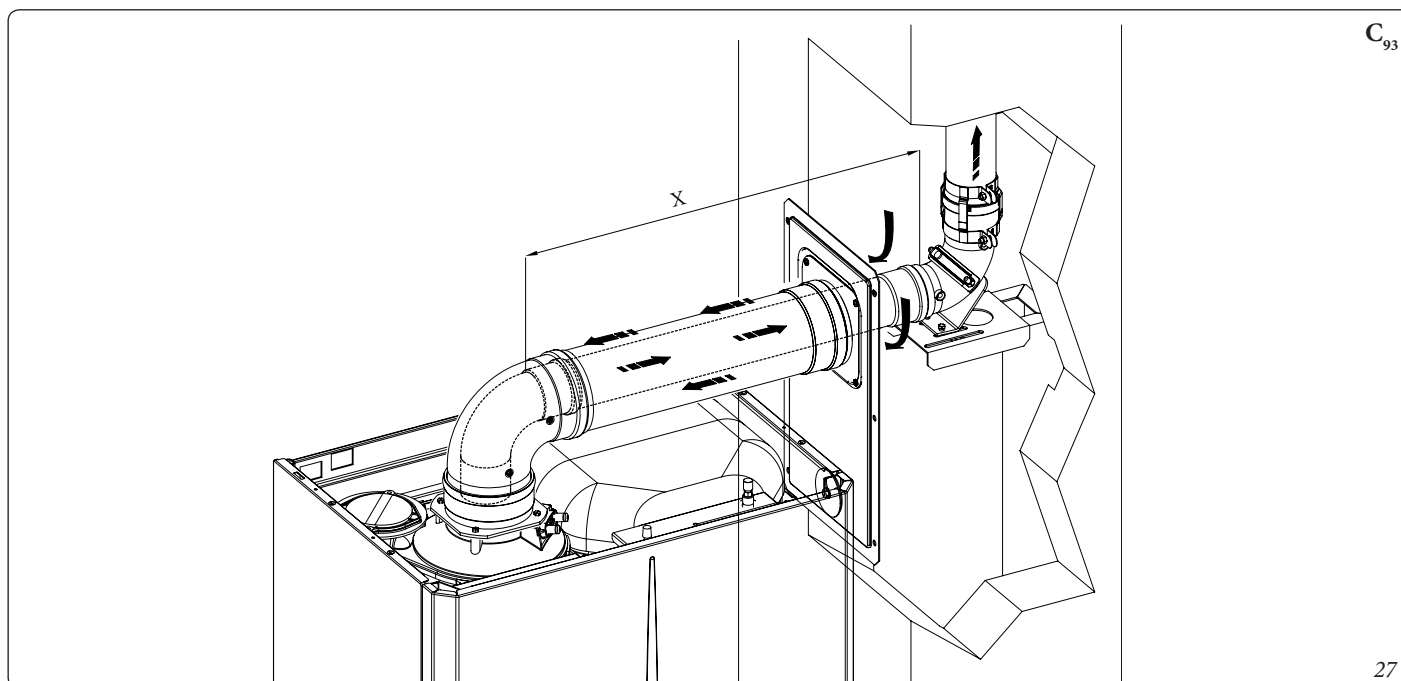

C_{93}

1.18 DUCTING OF FLUES OR TECHNICAL SLOTS.

Ducting is an operation through which by inserting one or more relevant pipes, one achieves a system for the evacuation of the combustion products of a gas appliance, consisting in the combination of an existing or new ducting pipe with a chimney, flue or technical slot (also in new buildings) (Fig. 28). Ducting requires ducts declared to be suitable for the purpose by the manufacturer, following the installation and user instructions, provided by the manufacturer and the requirements of the regulations in force.

Immergas ducting system.

The Ø 60 rigid, Ø50 and Ø 80 flexible and Ø80 rigid “Green Range” ducting systems must only be used for domestic use and with Immergas condensing boilers.

In any case, ducting operations must respect the provisions contained in the standard and in current technical regulations; in particular, the declaration of conformity must be compiled at the end of work and on commissioning of the ducted system. The instructions in the project or technical report must likewise be followed, in cases provided for by the standard and current technical regulations. To guarantee reliability and operation over time of the ducting system, make sure:

- it is used in average atmospheric and environmental conditions, according to current regulations (absence of combustion products, dusts or gases that can alter the normal thermophysical or chemical conditions; existence of temperatures coming within the standard range of daily variation, etc.).
- Installation and maintenance must be performed according to the indications supplied by the manufacturer included with the “green range” ducting system chosen and in compliance with the regulations in force.

- The maximum length specified by the manufacturer must be respected; in this regard:
 - The max. possible length of the Ø 60 flexible ducting vertical section is equal to 22 m. This length is obtained considering the complete Ø 80 exhaust terminal, 1m of Ø 80 pipe in exhaust, two 90° Ø 80 bends at boiler outlet.
 - The max. possible length of the Ø 80 flexible ducting vertical section is equal to 18 m. This length is obtained considering the Ø80 complete exhaust terminal, 1m of Ø 80 pipe in exhaust, two 90° Ø 80 bends at boiler outlet for connecting to the ducting system and two direction changes of the flexible hose inside the chimney/technical slot.
 - The max. possible length of the Ø 80 flexible ducting vertical section is equal to 30 m. This length is obtained considering the complete Ø 80 exhaust terminal, 1m of Ø 80 pipe in exhaust, two 90° Ø 80 bends at boiler outlet.

You can also install an additional Ø50 flexible ducting system the specifications of which are found on the relevant instructions sheet inside the kit.

1.19 CONFIGURATION TYPE B, OPEN CHAMBER AND FAN ASSISTED FOR INDOORS.

The appliance can be installed inside buildings in B₂₃ or B₅₃ mode; in this case, all technical rules and national and local regulations in force, must be complied with.

For installation the cover kit must be used, referred to in Par. 1.13.

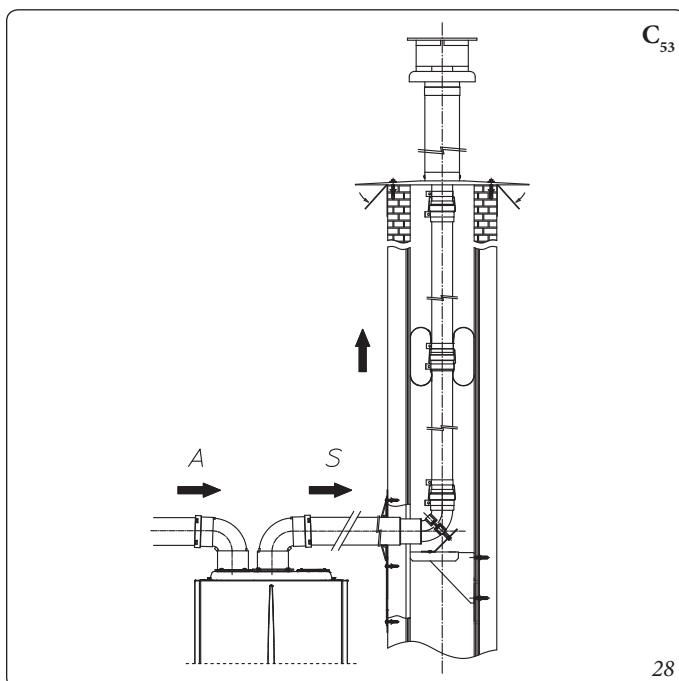

1.20 FLUE EXHAUST TO FLUE/CHIMNEY.

Flue exhaust does not necessarily have to be connected to a branched type traditional flue for type B appliances with natural draught (CCR). The flue exhaust, for boiler clots installed in C configuration, can be connected to a special LAS type multiple flue. For B₂₃ configurations, exhaust is only allowed into individual chimney or directly into the external atmosphere via a suitable terminal, unless otherwise provided for by local regulations in force. The multiple flues and the combined flues must also only be connected to type C appliances of the same type (condensation), having nominal heat inputs that do not differ by more than 30% less with respect to the maximum that can be attached and powered by the same fuel. The thermo-fluid dynamic features (flue flow rate, % of carbon dioxide, % humidity etc.) of the appliances attached to the same multiple flues or combined flues, must not differ by more than 10% with respect to the average boiler attached. Multiple and combined flues must be specially designed according to the calculation method and requirements of the standards (such as UNI EN 13384), by professionally qualified technical staff. Chimney or flue sections for connection of the flue exhaust pipe must comply with requisites of technical standards in force. It is possible to replace a type C conventional device with one provided with condensation only, if the derogation conditions established by the regulations in force have been verified.

1.21 FLUES, CHIMNEYS AND CHIMNEY CAPS.

The flues, chimneys and chimney caps for the evacuation of combustion products must be in compliance with applicable standards. Chimneys and roof-installed exhaust terminals must comply with the outlet height and with the distance from technical volumes set forth by the technical standards in force.

Positioning the wall flue exhaust terminals.

- The wall flue exhaust terminals must:
- be installed on external perimeter walls of the building;
 - be positioned according to the minimum distances specified in current technical standards.

Combustion products exhaust of natural draught or fan assisted appliances in open-top closed environments.

In spaces closed on all sides with open tops (ventilation pits, courtyards etc.), direct combustion product exhaust is allowed for natural draught or fan assisted gas appliances with a heat input range from 4 to 35 kW, provided the conditions as per the current technical standards are respected.

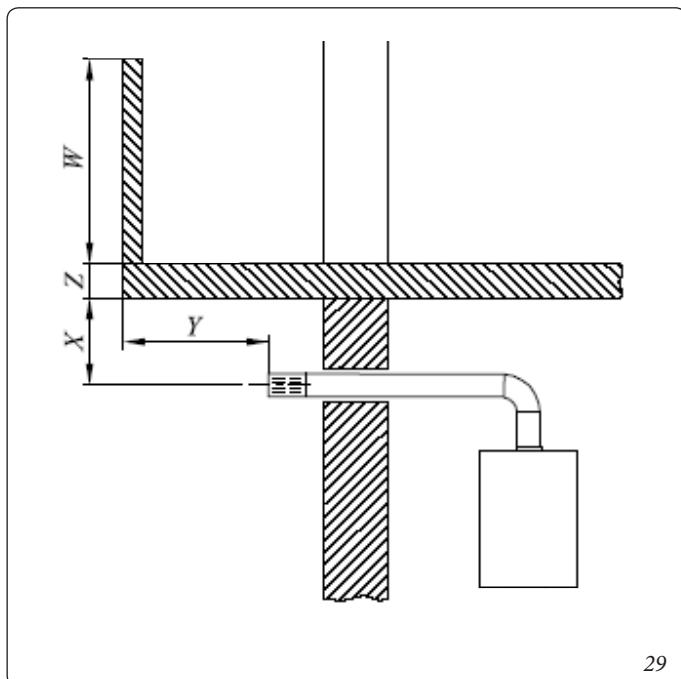

1.22 WATER TREATMENT SYSTEM FILLING.

As already mentioned in the previous paragraphs, a treatment of the thermal and domestic system water is required, in compliance with the local standards in force.

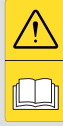

The parameters that influence the duration and proper operation of the heat exchanger are the water's PH, total hardness, conductivity, and oxygen, together with the system's processing residues (any welding residues), any oil present and corrosion products that can, in turn, cause damage to the heat exchanger.

In order to prevent this from happening, you are recommended to:

- Before installation on new systems as well as old ones, clean the system with clean water to eliminate solid residues contained therein
- Clean the system with a chemical treatment:
 - Clean the new system with a suitable cleaning device (for example Sentinel X300, Fernox Cleaner F3 or Jenaqua 300) combined with thorough washing.
 - Clean the old system with a suitable cleaning device (for example Sentinel X400 or X800, Fernox Cleaner F3 or Jenaqua 400) combined with thorough washing.
- Check the maximum total hardness and quantity of filling water referring to the graphics (Fig. 30); if the contents and hardness of the water are below the indicated curve, no specific treatment is required; otherwise, to limit the content of calcium carbonate, you must provide for water-filling treatment.
- Should you be required to provide for water treatment, this should be carried out by completely desalinating the filling water. As opposed to the complete softening process, desalinating the water completely not only removes hardening agents (Ca, Mg), but also eliminates all other minerals to reduce water-filling conductivity up to 10 microsiemens/cm. Given its low conductivity, desalinated water does not only prevent the formation of lime scale, but also serves as protection against corrosion.
- Insert a suitable inhibitor / passivator (for example Sentinel X100, Fernox Protector F1, or Jenaqua 100); if required, also insert appropriate antifreeze (such as for example Sentinel X500, Fernox Alpha 11 or Jenaqua 500).
- Check electrical conduction of the water, which should be higher than 2000 $\mu\text{s}/\text{cm}$ in the case of treated water and lower than 600 $\mu\text{s}/\text{cm}$ in the case of non-treated water.
- To prevent corrosion, the water system's PH should be between 6.5 and 8.5.
- Check the maximum content of chlorides, which should be less than 250 mg/l.

N.B.: for quantities and methods of use of water-treatment products, refer to the instructions provided by their manufacturer.

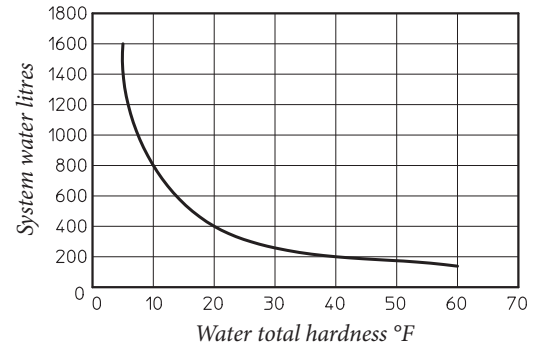

N.B.: the graph refers to the entire life cycle of the system. Therefore, also consider scheduled and unscheduled maintenance, which involves emptying and filling the said system.

30

1.23 SYSTEM FILLING.

Once the boiler is connected, proceed with system filling via the filling cock (Part. 1 Fig. 32). Filling is performed at low speed to ensure release of air bubbles in the water via the boiler and central heating system vents.

The boiler has a built-in automatic vent valve on the pump. Check if the cap is loose. Then open the radiator vent valves.

Close radiator vent valves when only water escapes from them. Close the filling valve when the boiler pressure gauge indicates approx. 1.2 bar.

N.B.: during these operations, enable the automatic vent functions on the boiler.

1.24 FILLING THE CONDENSATE DRAIN TRAP.

On first lighting of the boiler, flue gas may come out the condensate drain; after a few minutes' operation check that this no longer occurs. This means that the drain trap is filled with condensate to the correct level preventing the passage of flue gas.

1.25 GAS SYSTEM START-UP.

To start up the system, refer to the technical standards in force. In particular, for new gas systems:

- open windows and doors;
- avoid presence of sparks or naked flames;
- bleed all air from pipelines;
- ensure the internal system is properly sealed according to the specifications set forth by technical regulations in force.

1.26 BOILER START-UP (IGNITION).

To commission the boiler (the operations listed below must only be performed by qualified personnel and in the presence of staff only):

- check that the internal system is properly sealed according to the specifications set forth by regulations in force;
- ensure that the type of gas used corresponds to the boiler settings (the type of gas appears on the display on first electrical power supply, or by checking the relative parameter "G");
- check that there is no air in the gas pipe;
- check connection to a 230V-50Hz power mains, correct L-N polarity and the earthing connection;
- check that the intake/exhaust terminals are not obstructed and that they are installed properly;
- check that the drain trap is full and that it prevents any passage of flue gas into the room;
- check that there are no external factors that may cause the formation of fuel pockets;
- perform the flue test and, if needed, set the correct value of the parameter "F0" (Par. 3.14);
- activate the quick calibration function (Par. 3.13);
- switch the boiler on and ensure correct ignition;
- make sure that the gas flow rate and relevant pressure values comply with those given in the manual (Par. 4.1);
- ensure that the safety device intervenes in the event of gas supply failure and check the relative intervention time;
- check the intervention of the main switch located upstream from the boiler and in the boiler.

The system must not be started up if even only one of the checks should be negative.

1.27 CIRCULATION PUMP.

During central heating mode, the Auto and Fixed operating modes are available.

- **Auto (A5 = 0):** automatic circulator pump speed and proportional head: The automatic circulator pump speed varies according to the power emitted by the burner; the greater the power, the greater the speed. Moreover, within the parameter, one can also adjust the circulator pump operating range by setting the maximum speed "A3" parameter (adjustable from 6 to 9) and the "A4" minimum speed parameter (adjustable from 6 to the max. set speed).
- **ΔT Constant (A5 = 5 ÷ 25 K):** the pump speed varies to maintain the ΔT constant between the system flow and return according to set value K (**A5 = 15 Default**).
- **Fixed (6 ÷ 9):** by setting parameters "A3" and "A4" at the same value, the pump operates at constant speed.

N.B.: for the boiler to work properly, it is not allowed to drop below the minimum value indicated above.

In domestic hot water mode, the circulator pump always runs at full speed.

Pump release. If after a long period of inactivity, the circulator is blocked, adjust the screw in the centre of the head in order to manually release the motor shaft. Take great care during this operation to avoid damage to the motor.

By-pass Regulation (Part. 3 Fig.32).

The boiler leaves the factory with the bypass open.

If necessary, the bypass can be regulated to system requirements from minimum (bypass closed) to maximum (bypass open). Adjust using a flat-head screwdriver. Turning clockwise opens the bypass and anticlockwise closes it.

1.28 CIRCULATION PUMP WITH NEW WAVE 3 ELECTRONICS.

Pump LED.

When the pump is powered, the LED lights up with a steady green light.

When the pump is switched on, the green LED flashes at higher intensity and then returns to normal intensity with a steady green light.



If the pump detects an alarm, the LED switches from green to red; this can mean one of the following failures:

- low supply voltage;
- rotor seized;
- electrical error.

To see in detail the meaning of the red LED, please refer to the relevant paragraph (3.7 Possible problems and their causes).

The LED, in addition to being green or red, can also remain off.



It is normal for the LED to be off when the pump is not powered, whereas with the pump powered, the LED must be lit: if switched off, it means there is a fault.

Pump release. If after a long period of inactivity, the circulator is blocked, adjust the screw in the centre of the head in order to manually release the motor shaft. Take great care during this operation to avoid damage to the motor.

By-pass Regulation (Part. 3 Fig.32).

The boiler leaves the factory with the bypass open.

If necessary, the bypass can be regulated to system requirements from minimum (bypass closed) to maximum (bypass open). Adjust using a flat-head screwdriver. Turning clockwise opens the bypass and anticlockwise closes it.

Total head available to the system.

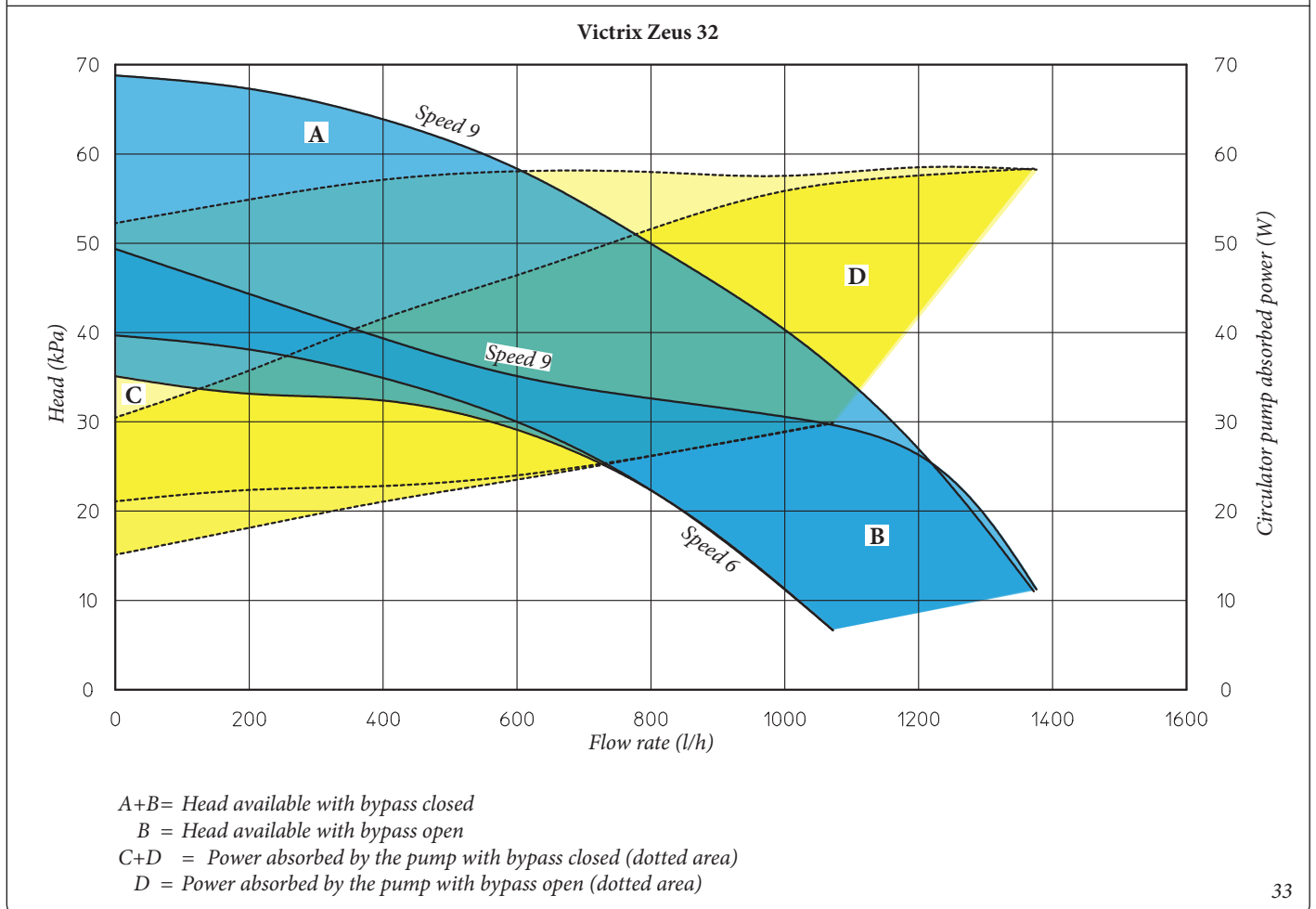
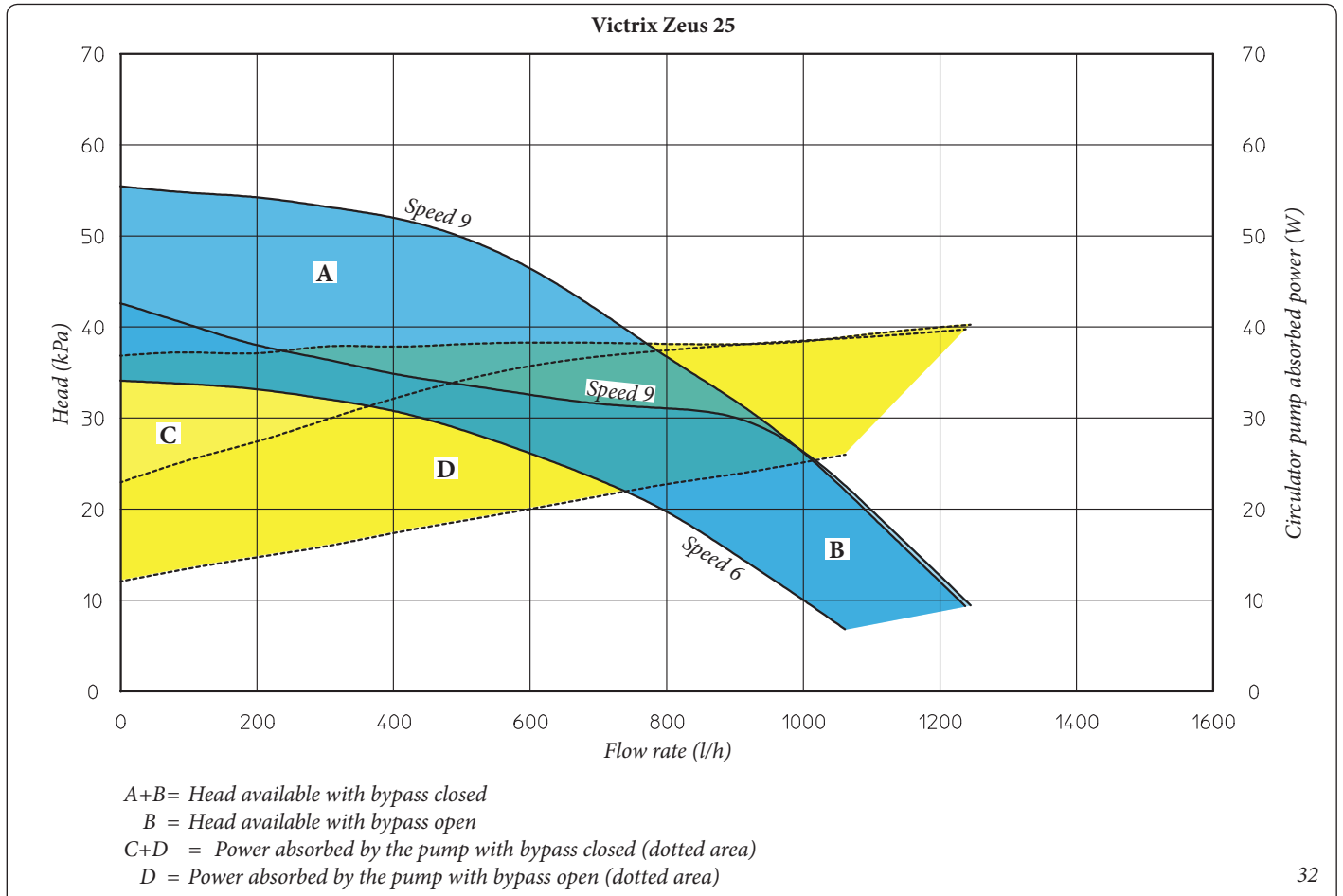

1.29 KITS AVAILABLE ON REQUEST.

- System cut-off valve kits with or without inspectionable filter (on request). The boiler is designed for installation of system interception cocks to be placed on flow and return pipes of the connection assembly. This kit is very useful for maintenance because it allows to empty just the boiler without having to empty the entire system. Moreover, the version with filter preserves the functioning characteristics of the boiler thanks to its inspectionable filter.
- System zone control unit kit (on request). If the central heating system is to be divided into several zones (**max. three**), in order to interlock them with separate adjustments and to keep water flow rate high for each zone, Immergas supplies zone system kits by request.
- Polyphosphate dispenser kit (on request). The polyphosphate dispenser reduces the formation of lime-scale and preserves the original heat exchange and domestic hot water production conditions. The boiler is prepared for application of the polyphosphate dispenser kit.

N.B.: this is a type of chemical conditioning treatment for domestic hot water, if provided for by current regulations.

- Relay board (on request). The boiler is prepared for the installation of a relay board that allows to increase the features of the appliance and therefore functioning possibilities.
- Cover kit (on request). If installed outdoors in a partially protected place with direct air intake, it is compulsory to mount the appropriate top protective cover for the correct functioning of the boiler and to protect it from adverse weather conditions.
- Cycloidal filter kit (on request). The magnetic cycloidal filter is able to detect the ferrous residues present in the system's water. Thanks to the two cocks in the kit, it facilitates maintenance by cleaning the filter without having to empty the circuit.

The above-mentioned kits are supplied complete with instructions for assembly and use.

INSTALLER

USER

MAINTENANCE TECHNICIAN

1.30 BOILER COMPONENTS.

INSTALLER

USER

MAINTENANCE TECHNICIAN

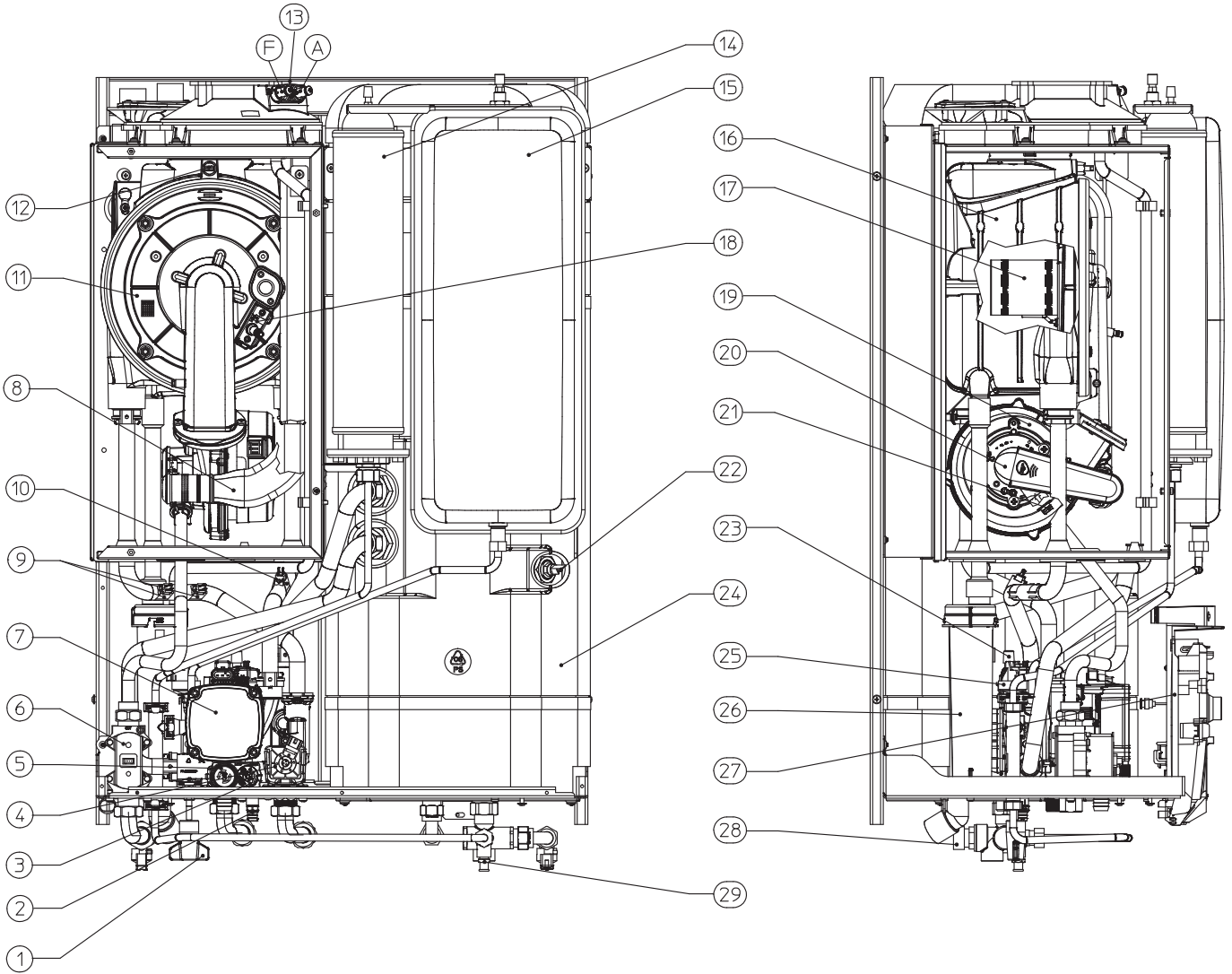

Key:

- 1 - Filling valve system
- 2 - Draining valve system
- 3 - Bypass
- 4 - 3-way valve (motorised)
- 5 - 3 bar safety valve
- 6 - Gas valve
- 7 - Boiler pump
- 8 - Air intake pipe
- 9 - Flow probe
- 10 - Return probe

- 11 - Air / gas manifold
- 12 - Flue probe
- 13 - Flue gas sample points
(air A) - (flue gas F)
- 14 - Domestic hot water
expansion vessel
- 15 - System expansion vessel
- 16 - Condensation module
- 17 - Burner
- 18 - Ignition/detection
electrodes

- 19 - Fan
- 20 - Air / gas mixer
- 21 - Gas nozzle
- 22 - D.H.W. probe
- 23 - Air vent valve
- 24 - Stainless steel storage tank
- 25 - System pressure switch
- 26 - Condensate drain trap
- 27 - Control panel
- 28 - 8 bar safety valve
- 29 - Storage tank draining fitting

2 INSTRUCTIONS FOR USE AND MAINTENANCE.

2.1 GENERAL WARNINGS.

ATTENTION:

- Never expose the wall-mounted boiler to direct vapours from a cooking surface. 
- The device can be used by children at least 8 years old as well as by persons with reduced physical, sensory or mental capabilities, or lack of experience or required knowledge, provided that they are under surveillance, or after they have been instructed relating to the safe use and have understood the potential dangers. Children must not play with the appliance. Cleaning and maintenance destined to be performed by the user can not be carried out by unsupervised children.
- For safety purposes, check that the air intake/flue exhaust terminals (if fitted) are not blocked.
- If temporary shutdown of the boiler is required, proceed as follows:
 - a) drain the heating system if antifreeze is not used;
 - b) shut-off all electrical, water and gas supplies.
- In the case of work or maintenance to structures located in the vicinity of ducting or devices for flue extraction and relative accessories, switch off the appliance and on completion of operations ensure that a qualified technician checks efficiency of the ducting or other devices.
- Never clean the appliance or connected parts with easily flammable substances.
- Never leave containers or flammable substances in the same environment as the appliance.

- Do not open or tamper with the appliance. 
- Do not take apart or tamper with the intake and exhaust pipes.
- Only use the user interface devices listed in this section of the booklet.
- Do not climb on the appliance, do not use the appliance as a supporting surface.

ATTENTION:

- The use of components involving use of electrical power requires some fundamental rules to be observed such as: 
- do not touch the appliance with wet or moist parts of the body; do not touch when bare-foot;
 - never pull electrical cables or leave the appliance exposed to atmospheric agents (rain, sunlight, etc.);
 - if the power cable is damaged, it must be replaced by a cable or special assembly by contacting a qualified company (e.g. the Immergas Authorised After-Sales Technical Assistance Service) for its replacement to avoid a hazard.
 - if the appliance is not to be used for a certain period, disconnect the main power switch.

ATTENTION:

water at a temperature of more than 50 °C can cause serious burns. Always check the water temperature before any use. 

The temperatures indicated by the display have a tolerance of +/- 3°C due to environmental conditions that cannot be blamed on the boiler. 

ATTENTION:

if you smell gas in the building:



- close the gas meter interception device or the main interception device;
- if possible, close the gas interception cock on the product;
- if possible, open doors and windows wide and create an air current;
- do not use open flames (e.g. lighters, matches);
- do not smoke;
- do not use electrical switches, plugs, door bells, telephones or intercom devices in the building;
- call an authorised company (e.g. the Immergas Authorised After-Sales Technical Assistance Service).

ATTENTION:

if you smell burning or see smoke coming out of the appliance, switch it off, disconnect the power, close the main gas cock, open the windows and call an authorised company (e.g. the Immergas Authorised After-Sales Technical Assistance Service).

**ATTENTION:**

At the end of its service life, the appliance must not be disposed of like normal household waste nor abandoned in the environment, but must be removed by a professionally authorised company as required by current legislation. Contact the manufacturer for disposal instructions.



2.2 CLEANING AND MAINTENANCE.

To preserve the boiler's integrity and keep the safety features, performance and reliability, which distinguish it, unchanged over time, you must execute maintenance operations on a yearly basis in compliance with what is stated in the relative point at “annual check and maintenance of the appliance”, in compliance with national, regional, or local standards in force. Annual maintenance is essential to validate the conventional warranty of Immergas.



2.3 CONTROL PANEL.

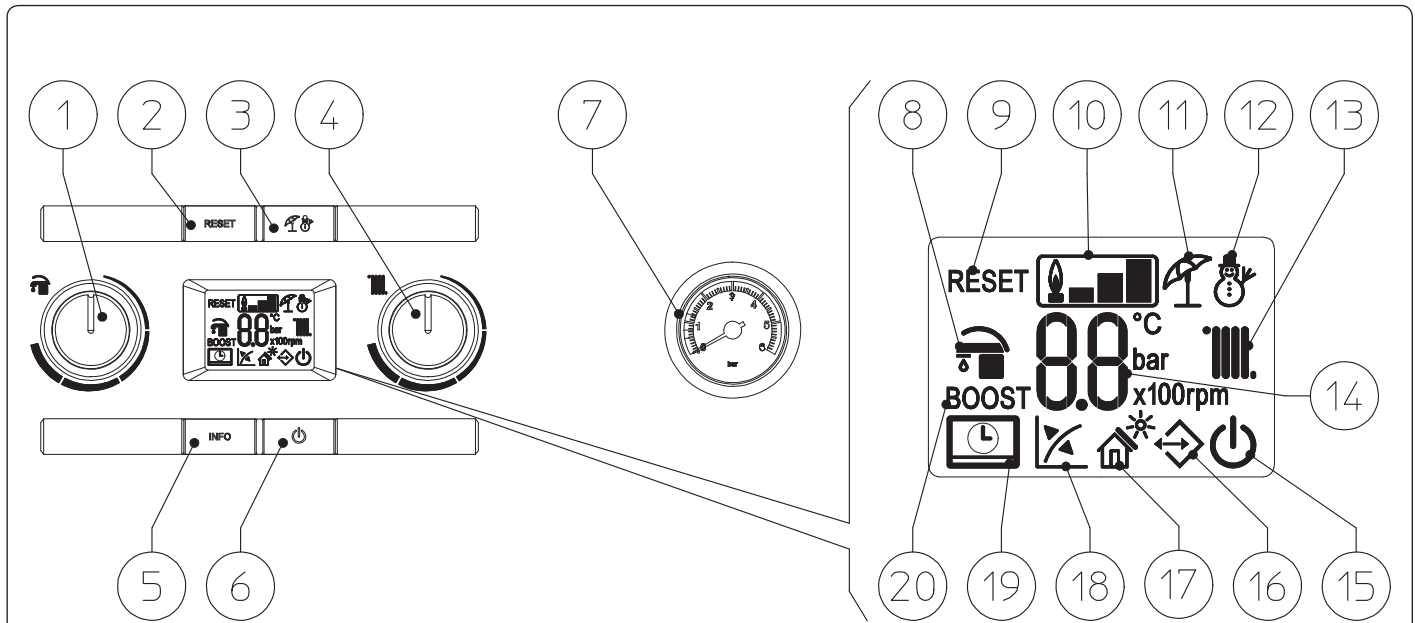

- Key:
- | | | |
|---|---|--|
| 1 - Domestic hot water temperature selector | 9 - Blocked boiler, it needs to be unblocked by pressing the “RESET” button | 14 - Temperature indicator, boiler info and error codes |
| 2 - Reset Button | 10 - Flame presence symbol and relative output scale | 15 - Boiler in Stand-by mode |
| 3 - Summer/Winter Button | 11 - Operation in summer mode | 16 - Presence of external connected devices |
| 4 - Central heating temperature selector | 12 - Operation in winter mode | 17 - Not used on this model |
| 5 - Information buttons | 13 - Room central heating mode functioning active | 18 - Operation with external temperature probe active (optional) |
| 6 - Off/Stand-by/On Button | | 19 - Boiler connected to remote control ^{v2} (optional) |
| 7 - Boiler manometer | | 20 - Not used on this model |
| 8 - DHW production phase function active | | |

2.4 USING THE BOILER.

Before ignition make sure the heating system is filled with water and that the manometer (7) indicates a pressure of 1 ÷ 1.2 bar.

- Open the gas cock upstream from the boiler.
- Press the button (🔌) until the display switches on. At this point, the boiler goes to the state previous to switch-off.
- If the boiler is on “Stand-by”, press (🔌) again to enable it, otherwise go to the next point.
- Then press the button (🌸) in sequence and set the boiler in the summer (🌸) or winter (🌨) position.
- **Summer (🌸):** in this mode the boiler only works to produce DHW; the temperature is set via the selector (1) and the relative temperature is shown on the display via the indicator (14).

- **Winter (🌨):** in this mode the boiler works both for producing domestic hot water and for central heating. The temperature of the DHW is always regulated via the selector (1), the heating temperature is regulated via selector (4) and the relative temperature is shown on the display via the indicator (14).

From this moment the boiler functions automatically. With no demand for heat (central heating or domestic hot water production) the boiler goes to “standby” function, equivalent to the boiler being powered without presence of flame. Each time the burner ignites, the relative symbol (🔌) is displayed.

- **Operation with Comando Amico Remoto remote control ^{v2} (CAR^{v2}) (Optional).** If the CAR^{v2} is connected, the (🔌) symbol will appear on the display. The boiler regulation parameters can be set via the CAR^{v2} control panel and the RESET button remains active on the boiler control panel, along with (🔌) for switch-off (“off” mode only) and the display where the functioning state is shown.

Caution: if the boiler is switched “off” the CAR^{v2} will display the connection error symbol “ERR>CM”, the CAR^{v2} is however powered constantly so as not to lose the stored programs.

- **Operation with optional external probe (🌡).** In the case of a system with optional external probe, the boiler flow temperature for room central heating is managed by the external probe depending on the external temperature measured (Par. 1.10). The flow temperature can be modified by selecting the functioning curve via the selector switch (4) (or on the CAR^{v2} control panel, if connected to the boiler) selecting a value from “0 to 9”.

With external probe present, the relative symbol (🌡) will appear on the display. In the central heating mode, if the temperature of the water contained in the system is sufficient to heat the radiators, the boiler can only function with the activation of the pump.

- **Standby mode.** Press button (6) until the (🔌) symbol appears. The boiler remains active from this moment and the anti-freeze function, pump anti-block function and 3-way and signalling of any anomalies is guaranteed.

“Off” mode. By holding the button (🔌) down for 8 seconds, only the central point remains lit on the display, and all boiler functions are disabled. The safety functions are not guaranteed in this mode.

ATTENTION:

in “Stand-by” and “Off” mode, the boiler is still powered.



- **“Automatic vent” mode.** When the function is enabled, every time the boiler is electrically powered, the system automatic vent function is activated (lasting 8 minutes). This function is displayed via a countdown signalled by the indicator (14). During this period the DHW and CH functions are not active.

The “automatic vent” function can be annulled by pressing the “RESET” button.

- **Display operation.** The display lights up while the control panel is being used; after a set inactivity period, the brightness decreases. The lighting mode can be varied via parameter t8 in the P.C.B. programming menu.

2.5 FAULT AND ANOMALY SIGNALS.

The boiler signals any anomalies using a code shown on the boiler display (14) according to the following table:

Error Code	Anomaly signalled	Cause	Boiler status / Solution
01	No ignition ignition	In the event of request of room central heating or domestic hot water production, the boiler does not switch on within the preset time. Upon appliance commissioning or after extended downtime, it may be necessary to eliminate the block.	Press the Reset button (1)
02	Safety thermostat function block	During normal operation, if a fault causes excessive overheating internally, the boiler goes into overheating block.	Press the Reset button (1)
03	Flue safety thermostat block	During normal operation, if a fault causes excessive flue gas overheating, the boiler blocks	Press the Reset button (1)
04	Contacts resistance block	The P.C.B. detects a fault on the gas valve supply. Check its connection. (the anomaly is detected and displayed only in the event of a request).	Press the Reset button (1)
05	Flow probe anomaly	The board detects an anomaly on the flow NTC probe.	The boiler does not start (1)
08	Maximum N° of resets	Number of allowed resets already performed.	The anomaly can be reset 5 times consecutively, after which the function is inhibited for at least one hour. One attempt is gained every hour for a maximum of 5 attempts. By switching the appliance on and off again, the 5 attempts are re-acquired.
10	Insufficient system pressure	Water pressure inside the central heating circuit that is sufficient to guarantee the correct operation of the boiler is not detected.	Check on the boiler pressure gauge that the system pressure is between 1÷1.2 bar and restore the correct pressure if necessary.
12	Storage tank probe anomaly	The board detects an anomaly on the storage tank probe.	The boiler cannot produce domestic hot water (1).
15	Configuration error	If the board detects an anomaly or incongruity on the electric wiring, the boiler will not start.	If normal conditions are restored the boiler restarts without having to be reset. Check that the boiler is configured correctly (1)
16	Fan anomaly	This occurs if the fan has a mechanical or electrical fault.	Press the Reset button (1)
20	Parasite flame block	This occurs in the event of a leak on the detection circuit or anomaly in the flame control unit.	Press the Reset button (1)
23	Return probe anomaly	The board detects an anomaly on the return NTC probe.	The boiler does not start (1)
24	Push button control panel anomaly	The board detects an anomaly on the pushbutton panel.	If normal conditions are restored the boiler restarts without having to be reset (1).
29	Flue probe anomaly	The board detects an anomaly on the flue probe	The boiler does not start (1)
31	Loss of remote control communication	This occurs if an incompatible remote control is connected, or if communication between the boiler and the remote control is lost.	Disconnect and reconnect the power to the boiler. If the Remote Control is still not detected on re-starting, the boiler will switch to local operating mode, i.e. using the controls on the control panel. In this case the "Central Heating" (1) function cannot be activated.
36	IMG Bus communication loss	Communication between the various components is interrupted due to an anomaly on the boiler control unit, on the zone control unit (optional) or on the IMG Bus.	The boiler does not satisfy the room heating requests (1)
37	Low power supply voltage	This occurs when the power supply voltage is lower than the allowed limits for the correct boiler operation.	If normal conditions are restored the boiler restarts without having to be reset (1)
38	Loss of flame signal	This occurs when the boiler is ignited correctly and the burner flame switches off unexpectedly; a new attempt at ignition is performed and if normal conditions are restored, the boiler does not have to be reset.	If normal conditions are restored the boiler restarts without having to be reset (1) (2)
43	Block due to loss of flame signal	This occurs if the "Flame signal loss" error occurs many times in a row within a preset period (38).	Press the Reset button, before restarting, the boiler will run a post-ventilation cycle. (1)

(1) If the shutdown or fault persists, contact an authorised company (e.g. Authorised Technical After-Sales Service)
(2) The anomaly can only be verified in the list of errors in the "Information" menu

Error Code	Anomaly signalled	Cause	Boiler status / Solution
44	Block for exceeding the maximum accumulated time, close gas valve opening	This occurs if the gas valve remains open for longer than required for normal operation, without the boiler switching on.	Press the Reset button (1)
45	High ΔT	The boiler detects a sudden, unexpected increase in the ΔT between the flow probe and the system return probe.	The power of the burner is limited to prevent damage to the condensation module and once the right ΔT is restored, the boiler resumes regular operation. Make sure there is water circulating in the boiler, that the pump is configured according to system requirements and that the return probe works properly (1) (2).
46	Low temperature thermostat triggered (optional)	During normal operation, if an anomaly causes excessive overheating of the flow temperature in low temperature conditions, the boiler blocks.	In this case, after suitable cooling, it is possible to reset the thermostat (see relative instructions sheet). (1).
47	Burner power limitation	Should flue high temperature be detected, the boiler reduces power supplied so as not to damage it.	(1)
51	CAR Wireless communication failure	If there is no communication between the boiler and Wireless version CAR, an anomaly is signalled. From this moment, it is only possible to control the system by means of the control panel of the boiler itself.	Check operation of the Wireless CAR, check the battery charge (refer to the relative instructions booklet).
59	Main supply voltage frequency block	The board detects a main supply voltage frequency anomaly	The boiler does not start (1)
60	Anomaly pump blocked	The pump is stopped due to one of the following causes: Impeller blocked, electrical fault	Try to unblock the pump as described in the relative section. If normal conditions are restored the boiler restarts without having to be reset (1)
61	Air in circulator	Air is detected inside the pump; the pump cannot work	Vent the pump and the central heating circuit. If normal conditions are restored the boiler restarts without having to be reset (1)
62	Complete calibration required	Missing calibration is detected by the P.C.B. It may occur in the event the P.C.B. is replaced or if the parameters are altered in the air / gas section, thus requiring "complete calibration".	The boiler does not start (1)
72	Fast calibration required	The P.C.B. detects that some parameters have been altered, thus requiring "fast calibration".	The boiler does not start (1)
73	High flow probe and safety flow probe deviation detected.	The board detects an anomaly in the temperature readings of the NTC flow probes; the causes may be: faulty probe, incorrect position, poor system circulation, or clogging of the water side primary heat exchanger.	If normal conditions are restored the boiler restarts without having to be reset (1)
74	Safety flow probe anomaly	The board detects an anomaly on the NTC safety flow probe	The boiler does not start (1)
77	Combustion control anomaly	Out of range current is detected on the gas valve	The boiler does not start (1)
78	Combustion control anomaly	High current on the gas valve is detected	The boiler does not start (1)
79	Combustion control anomaly	Reduced current on the gas valve is detected	The boiler does not start (1)
80	P.C.B. malfunction block	This occurs in the event of malfunctions of the P.C.B. that controls the valve.	Press the Reset button (1)
84	Combustion anomaly - power reduction in progress	A low supply pressure is detected on the gas line. As a result the appliance power is limited and the anomaly is reported.	If normal conditions are restored the boiler restarts without having to be reset (1) (2)
87	Block - gas valve control	A malfunction of one of the components that controls the gas valve has been detected	The boiler does not start (1)
88	Block - gas valve control	A malfunction of one of the components that controls the gas valve has been detected	The boiler does not start (1)
89	Combustion signal unstable	The flame is unstable due to: presence of flue gas recirculation, wind, unstable gas pressure, unstable fan speed, or due to system malfunction	The boiler keeps working (1) (2)

(1) If the shutdown or fault persists, contact an authorised company (e.g. Authorised Technical After-Sales Service)

(2) The anomaly can only be verified in the list of errors in the "Information" menu

Error Code	Anomaly signalled	Cause	Boiler status / Solution
90	Combustion signal beyond limit	The combustion signal is beyond the adjustment range required for an extended period of time	The boiler keeps working (1) (2)
91	Incorrect ignition block	The board has exhausted all possible actions in order to obtain optimal ignition of the burner	Press the Reset button (1)
92	Fan revs correction limit	The system has exhausted all possible corrections of the number of fan revs	The boiler keeps working (1) (2)
(1) If the shutdown or fault persists, contact an authorised company (e.g. Authorised Technical After-Sales Service)			
(2) The anomaly can only be verified in the list of errors in the “Information” menu			

Error Code	Anomaly signalled	Cause	Boiler status / Solution
93	Combustion signal beyond limit	The combustion signal is beyond the adjustment range required for a limited period of time.	The boiler keeps working (1) (2)
94	Combustion anomaly	A problem is detected on the combustion control, which may be due to: gas low pressure, flue recirculation, defective gas valve or P.C.B.	If normal conditions are restored the boiler restarts without having to be reset (1) (2)
95	Combustion signal discontinuous	The system detects a discontinuous combustion signal.	The boiler keeps working (1) (2)
96	Clogged flue	This occurs in the event an obstruction is detected in the flue system.	The boiler does not start (1) If normal conditions are restored the boiler restarts without having to be reset
98	Block - maximum no. of software errors	The maximum number of software errors possible has been reached.	Press the Reset button (1)
99	General block	A boiler anomaly has been detected	Press the Reset button (1)
(1) If the shutdown or fault persists, contact an authorised company (e.g. Authorised Technical After-Sales Service)			
(2) The anomaly can only be verified in the list of errors in the “Information” menu			

INSTALLER

USER

MAINTENANCE TECHNICIAN

2.6 INFORMATION MENU.

By pressing the button “INFO”; the “Information menu” is activated for at least 1 second, displaying some boiler operating parameters.

Press the “INFO” button (4) to scroll the various parameters.

To exit the menu, press the “INFO” button up to the end of the list, or by pressing the “RESET” button or by waiting for 15 minutes.

With the menu active, the indicator (14) will alternately show the indication of the parameter via the letter “d” plus the number of the parameter that is being displayed and the value of the parameter itself.

Id Parameter	Description
d 0.0	Not used
d 0.1	Displays the combustion signal
d 0.2	Displays the primary heat exchanger output instant heating flow temperature
d 0.3	Displays the instant storage tank unit temperature
d 0.4	Displays the values set for central heating set
d 0.5	Displays the values set for DHW set
d 0.6	Displays the external environment temperature (if optional external probe present) If the temperature is below zero, the value is displayed flashing.
d 0.7	Displays the temperature read on the flue probe (probe 1)
d 0.8	Displays the system return water temperature.
d 09	Displays the list of the last five anomalies. (to scroll the list, turn the CH temperature selector (4)). Turning the selector changes the set central heating and the boiler can be switched off.
d 1.0	Anomaly list reset. Once “d 1.0” is displayed, press the Reset button; deletion is confirmed via the “88” symbols flashing for two seconds.
d 1.1	Displays the temperature read on the safety flow probe
d 1.2	Displays the pump operating speed
d 1.3	Not used
d 1.4	Displays the pump flow rate (lh/100)
d 1.5	Displays the fan operating speed (rpm/100)
d 1.6	Displays the temperature read on the flue probe (probe 2)

2.7 BOILER SHUTDOWN.

Switch the boiler off by putting it in “off” mode, disconnect the onnipolar switch outside of the boiler and close the gas cock upstream from the appliance. Never leave the boiler switched on if left unused for prolonged periods.

2.8 RESTORE CENTRAL HEATING SYSTEM PRESSURE.

Periodically check the system water pressure. The boiler pressure gauge should read a value of between 1 and 1.2 bar.

If the pressure falls below 1 bar (with the circuit cold) restore normal pressure via the valve located at the bottom of the boiler (Fig. 34).

N.B.: close the valve after the operation.

If pressure values reach around 3 bar the safety valve may be activated.

In this case, remove water from a radiator air vent valve until a pressure of 1 bar is achieved, or ask for assistance from professionally qualified personnel.

In the event of frequent pressure drops, contact qualified staff for assistance to eliminate the possible system leakage.

2.9 DRAINING THE SYSTEM.

To drain the boiler, use the special draining valve (Fig. 34). Before draining, ensure that the filling cock is closed.

ATTENTION:

if glycol was input in the system's circuit, make sure it is discharged into the waste water system, pursuant to regulation EN 1717.



2.10 DRAINING THE DOMESTIC HOT WATER CIRCUIT.

To do this, always close the domestic cold water inlet upstream of the appliance.

Open any domestic hot water tap to discharge the pressure from the circuit.

2.11 STORAGE TANK DRAINING.

To drain the storage tank, use the special draining valve (Fig. 34).

N.B.: before performing this operation, close the boiler cold water inlet valve and open any DHW system hot water valve in order to let air into the storage tank.

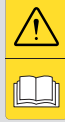

2.12 ANTIFREEZE PROTECTION.

The boiler has an antifreeze function that switches the burner on automatically when the temperature falls below 4°C (standard protection to minimum temperature of 0°C). All information relative to the antifreeze protection is stated in (Par. 1.4). In order to guarantee the integrity of the appliance and the domestic hot water heating system in zones where the temperature falls below zero, we recommend the central heating system is protected using anti-freeze liquid and installation of the Immergas Antifreeze Kit in the boiler. In the case of prolonged inactivity (second case), we also recommend that:

- the electric power supply is disconnected;
- the heating circuit and boiler domestic water circuit must be drained. In systems that are drained frequently, filling must be carried out with suitably treated water to eliminate hardness that can cause lime-scale.

2.13 CLEANING THE CASE.

Use damp cloths and neutral detergent to clean the boiler casing. Never use abrasive or powder detergents.

2.14 DECOMMISSIONING.

In the event of permanent shutdown of the boiler, contact professional staff for the procedures and ensure that the electrical, water and gas supply lines are shut off and disconnected.

2.15 GAS SYSTEM NOT USED FOR PERIODS OVER 12 MONTHS.

The current regulation provides that gas systems not used for over 12 months must be checked prior to being used again, as per regulations in force, by professionally qualified staff.

If the inspection is successful, the boiler can be recommissioned according to the instructions specified in point 3 herein.

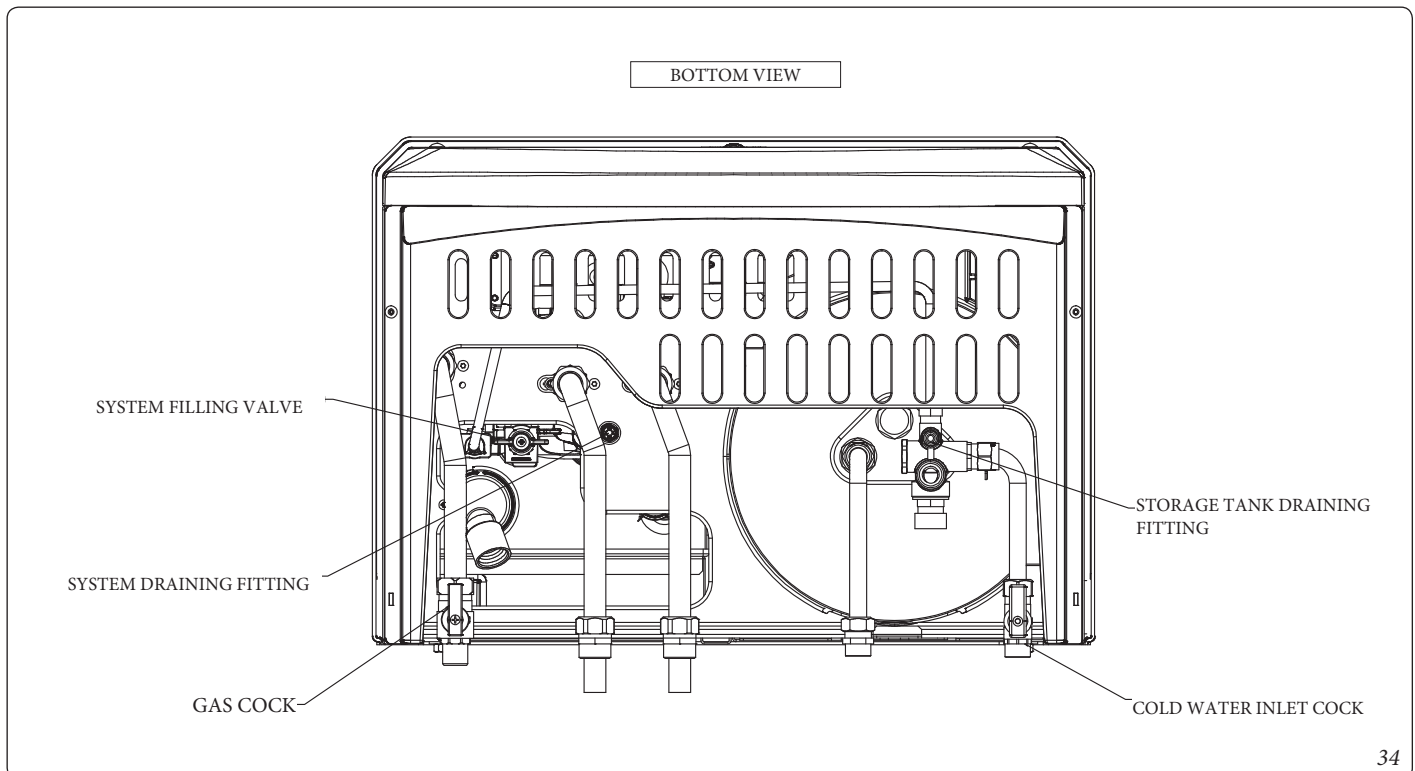

3 INSTRUCTIONS FOR MAINTENANCE AND INITIAL CHECK.

3.1 GENERAL WARNINGS.

ATTENTION:

operators who install and service the appliance must wear the personal protective equipment (PPE) required by applicable law.



Note: the list of possible PPE is not complete as they are indicated by the employer.

ATTENTION:

before performing any maintenance operation, make sure:

- you have disconnected the power to the appliance;
- you have closed the gas cock;
- you have discharged the pressure from the system and domestic hot water circuit.



Risk of material damage after using sprays and liquids to search for leaks.

Leak sprays and liquids clog the reference hole P.Ref (Part. 5 Fig. 38) of the gas valve, damaging it irreparably.

During installation and maintenance, do not use spray or liquids in the upper area of the gas valve (side referring to the electric connections).

Supply of spare parts.

The device's warranty shall be rendered null and void if unapproved or unsuitable parts are used for maintenance or repairs. These will also compromise the product's compliance, and the said product may no longer be valid and fail to meet the current regulations.

With regard to the above, only use Immergas original spare parts when replacing parts.



If additional documentation needs to be consulted for extraordinary maintenance, contact the Authorised After-Sales Service.



3.2 INITIAL CHECK.

To commission the boiler:



- ensure that the type of gas used corresponds to the boiler settings (the type of gas appears on the display on first electrical supply voltage, or by checking the relative parameter "G");
- check connection to a 230V-50Hz power mains, correct L-N polarity and the earthing connection;
- make sure the central heating system is filled with water and that the boiler manometer indicates a pressure of 1÷1.2 bar;
- switch the boiler on and ensure correct ignition;
- check the proper calibration of the number of fan revolutions;
- check the CO₂ flow rate in the flue:

- maximum
- intermediate
- minimum

the values must comply with what is indicated in the relative tables (Par. 3.3);

- check activation of the safety device in the event of no gas, as well as the relative activation time;
- check activation of the main switch located upstream of the boiler;
- check that the intake and/or exhaust terminals are not blocked;
- ensure activation of all adjustment devices;
- seal the gas flow rate regulation devices (if settings are modified);
- ensure production of domestic hot water;
- ensure sealing efficiency of water circuits;
- check ventilation and/or aeration of the installation room where provided.

Even if just one single safety check provides a negative result, do not commission the system.

3.3 YEARLY APPLIANCE CHECK AND MAINTENANCE.

The following checks and maintenance should be performed at least once a year to ensure operation, safety and efficiency of the appliance over time.



- Clean the flue side of the heat exchanger.
- Clean the main burner.
- Check the correct positioning, integrity and cleanliness of the detection and ignition electrode; remove any oxide present.
- If deposits are detected in the combustion chamber they must be removed and the heat exchanger coils must be cleaned using nylon or broomcorn brushes; it is forbidden to use brushes made of metal or other materials that may damage the combustion chamber. It is also forbidden to use alkaline or acid detergents.
- Check the integrity of the insulating panels inside the combustion chamber and if damaged replace them.
- Visually check for water leaks or oxidation from/on connections and traces of condensate residues inside the sealed chamber.
- Check the contents of the condensate drain trap.
- Check that there are no material residues in the condensate drain siphon clogging the condensate passage; also check that the entire condensate drainage circuit is clear and efficient.
In the event of obstructions (dirt, sediment, etc.) with consequent leakage of condensate in the combustion chamber, one must replace the insulating panels.
- Check that the burner and gas manifold seal gaskets are intact and perfectly efficient, otherwise replace them. In any case the gaskets must be replaced at least every two years, regardless of their state of wear.
- Check that the burner is intact, that it has no deformations or cuts and that it is properly fixed to the combustion chamber lid; otherwise it must be replaced.
- Visually check that the water safety drain valve is not blocked.
- Check that, after discharging the system pressure and bringing it to zero (read on boiler pressure gauge), the expansion vessel pressure is at 1.0 bar.
- Check that the system static pressure (with system cold and after refilling the system by means of the filling valve) is between 1 and 1.2 bar.
- Check visually that the safety and control devices have not been tampered with and/or shorted, in particular:
- Check the condition and integrity of the electrical system and in particular:
 - electrical power cables must be inside the fairleads;
 - there must be no traces of blackening or burning.

- Check correct lighting and operation.
- Check the CO₂ by using the chimney sweep function at the three reference heat outputs, using the parameters in the table below. Should values out of the indicated tolerance range be detected, check the integrity of the ignition / detection electrode and, if required, change it, also changing the relative gasket. At this point, activate the “complete calibration” function.
- Check correct operation of control and adjustment devices and in particular:
 - system regulation probes intervention;
 - domestic hot water control thermostat intervention.
- Check sealing efficiency of gas circuit and the internal system.
- Check the intervention of the device against no gas ionisation flame control. Intervention time must be less than 10 seconds.



Victrix Zeus 25 - 32			
	CO ₂ at nominal output	CO ₂ at intermediate output	CO ₂ at minimum output
G 20	9.20% ± 0.5	9.00% ± 0.5	9.00% ± 0.5
G 31	10.20% ± 0.5	10.00% ± 0.5	10.00% ± 0.5

In addition to yearly maintenance, one must also check the energy efficiency of the thermal system, with frequency and procedures that comply with the indications of the technical regulations in force.

INSTALLER

USER

MAINTENANCE TECHNICIAN

3.4 HYDRAULIC DIAGRAM.

INSTALLER

USER

MAINTENANCE TECHNICIAN

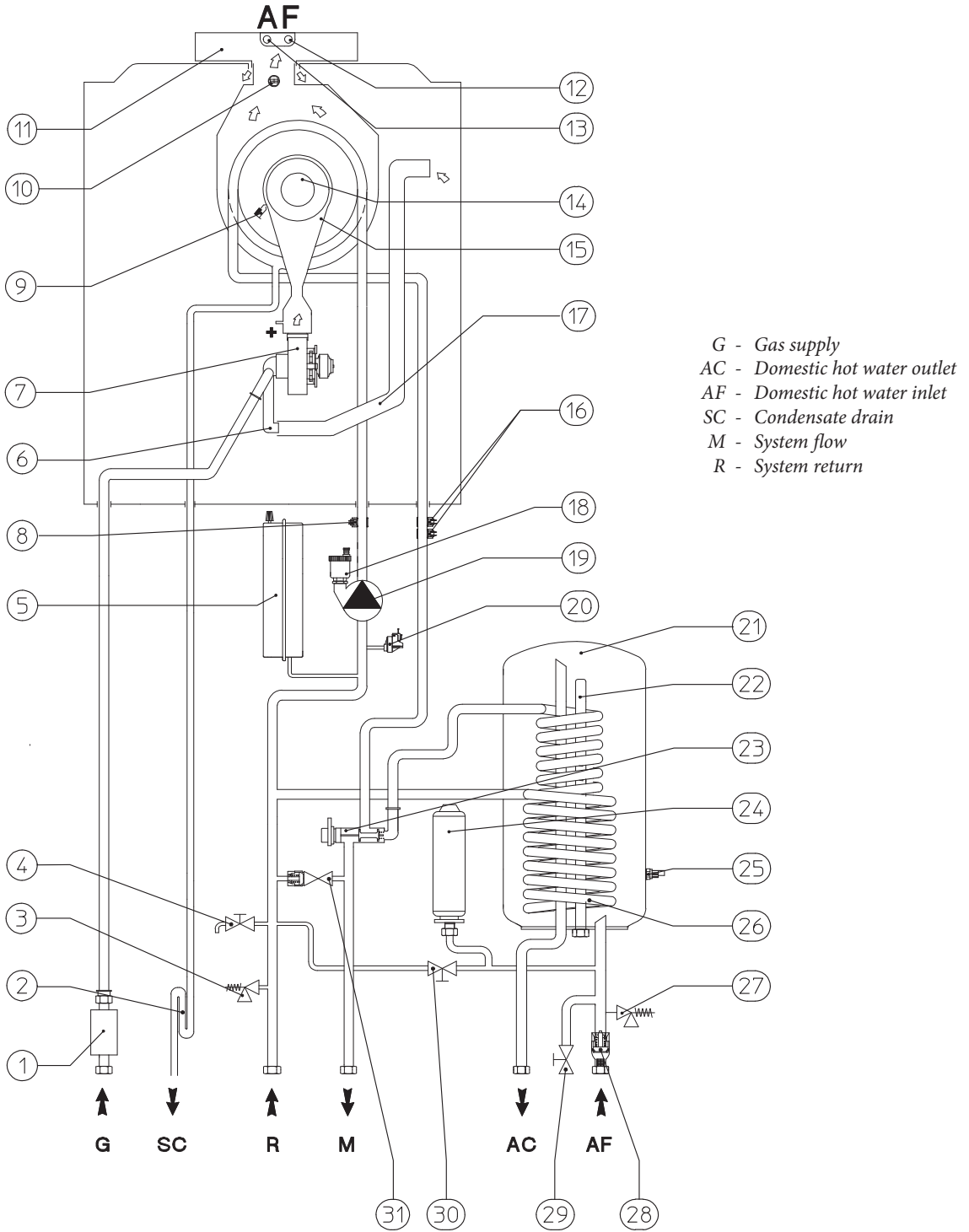

Key:

- | | | |
|----------------------------------|-----------------------------------|--|
| 1 - Gas valve | 12 - Flue sample point | 23 - 3-way valve (motorised) |
| 2 - Condensate drain trap | 13 - Air sample point | 24 - Domestic hot water expansion vessel |
| 3 - 3 bar safety valve | 14 - Burner | 25 - D.H.W. probe |
| 4 - System draining cock | 15 - Air / gas manifold | 26 - Stainless steel coil for storage tank |
| 5 - System expansion vessel | 16 - Flow probes | 27 - 8 bar safety valve |
| 6 - Air / gas mixer | 17 - Air intake pipe | 28 - Cold water inlet non-return valve |
| 7 - Fan | 18 - Air vent valve | 29 - Storage tank draining valve |
| 8 - Return probe | 19 - Boiler pump | 30 - System filling cock |
| 9 - Ignition/detection electrode | 20 - System pressure switch | 31 - Bypass |
| 10 - Flue probe | 21 - Stainless steel storage tank | |
| 11 - Flue hood | 22 - Magnesium anode | |

3.5 WIRING DIAGRAM.

Victrix Zeus 25

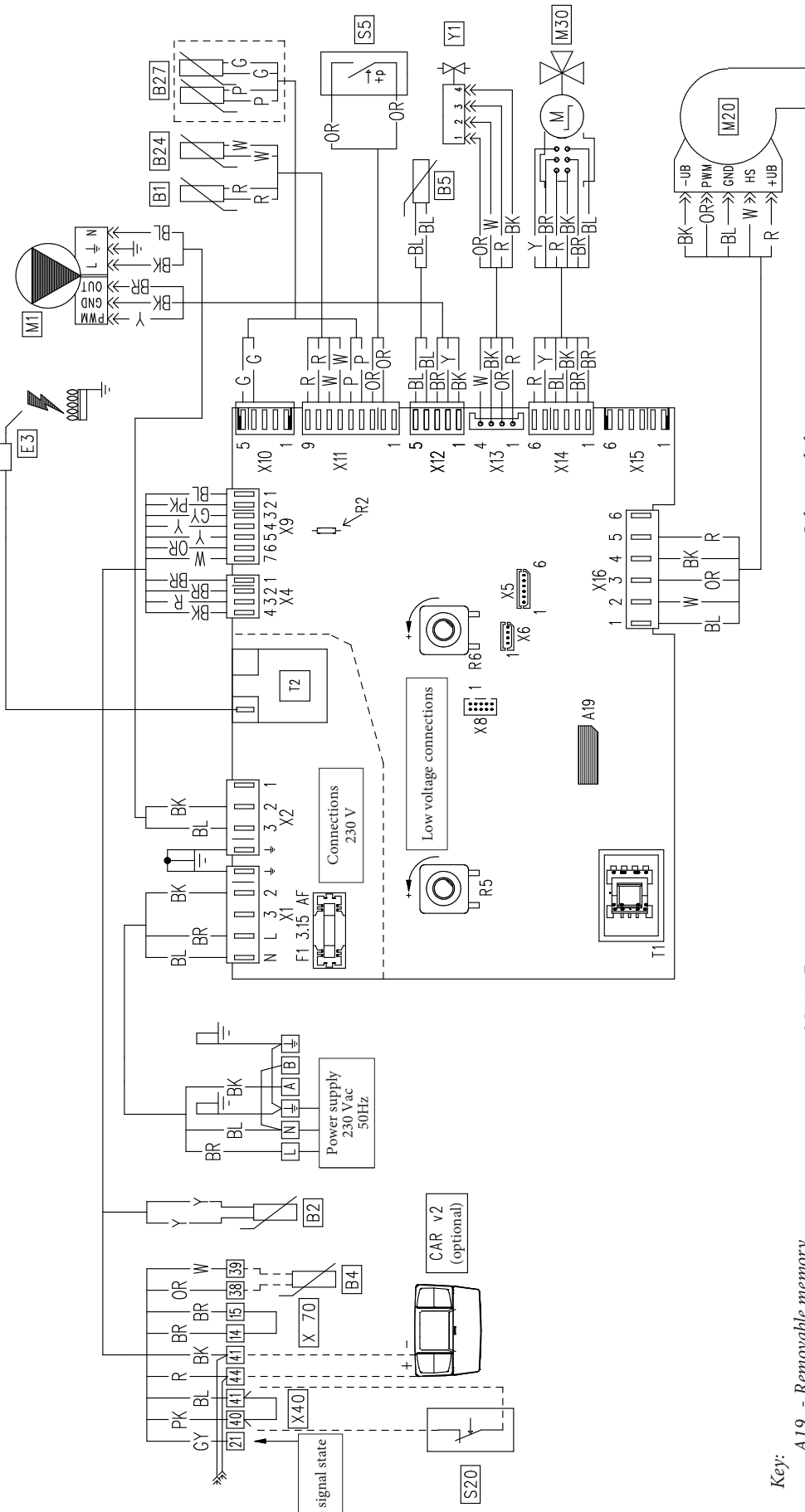

Key:

- A19 - Removable memory
- B1 - Flow probe
- B2 - Storage tank probe
- B4 - External probe (optional)
- B5 - Return probe
- B24 - Safety flow probe
- B27 - Double flue probe sensor
- CAR^{v2} - Comando Amico Remoto^{v2} remote control (optional)
- E3 - Ignition and detection electrode
- M1 - Boiler pump
- M20 - Fan
- M30 - Three-way motor stepper
- S5 - System pressure switch
- S20 - Room thermostat (optional)
- R5 - DHW temperature trimmer
- R6 - C.H. temperature trimmer
- T1 - Boiler P.C.B. transformer
- T2 - Ignition transformer
- X40 - Room thermostat jumper
- X70 - Safety thermostat (low temperature) jumper
- Y1 - Gas valve

Colour code key:

- BK - Black
- BL - Blue
- BR - Brown
- G - Green
- GY - Grey
- OR - Orange
- P - Purple
- PK - Pink
- R - Red
- W - White
- Y - Yellow
- Y/G - Yellow/Green

MAINTENANCE TECHNICIAN

USER

INSTALLER

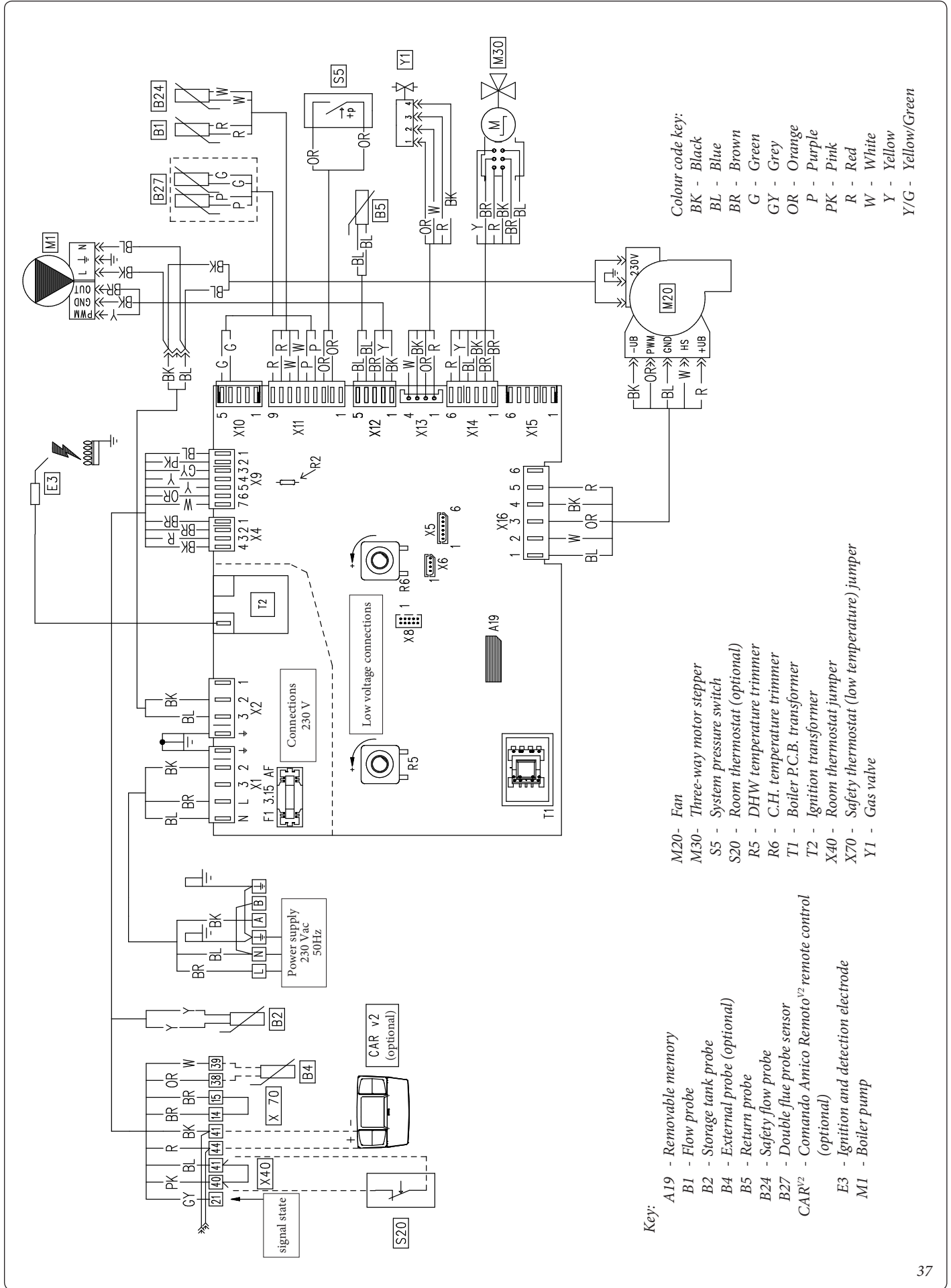

Colour code key:
 BK - Black
 BL - Blue
 BR - Brown
 G - Green
 GY - Grey
 OR - Orange
 P - Purple
 PK - Pink
 R - Red
 W - White
 Y - Yellow
 Y/G - Yellow/Green

- Key:
- A19 - Removable memory
 - B1 - Flow probe
 - B2 - Storage tank probe
 - B4 - External probe (optional)
 - B5 - Return probe
 - B24 - Safety flow probe
 - B27 - Double flue probe sensor
 - CAR^{v2} - Comando Amico Remoto^{v2} remote control (optional)
 - E3 - Ignition and detection electrode
 - M1 - Boiler pump
 - M20 - Fan
 - M30 - Three-way motor stepper
 - S5 - System pressure switch
 - S20 - Room thermostat (optional)
 - R5 - DHW temperature trimmer
 - R6 - C.H. temperature trimmer
 - T1 - Boiler P.C.B. transformer
 - T2 - Ignition transformer
 - X40 - Room thermostat jumper
 - X70 - Safety thermostat (low temperature) jumper
 - Y1 - Gas valve

Any room thermostat or ON-OFF must be connected to clamps 40 and 41 eliminating jumper X40.

Any CAR^{V2} must be connected to terminals 44 and 41 complying with the polarity and eliminating jumper X40.

The connector X5 is used for the connection to the relay board.

The connector X6 is for connection to a personal computer.

The connector X8 is used for software updating operations.

3.6 REMOVABLE MEMORY.

The P.C.B. is equipped with a removable memory (Ref. 2 Fig. 39), which records all operation parameters and system customisations.

Should the P.C.B. be replaced, you can use the memory of the replaced board again, so it is not necessary to reconfigure the appliance.

ATTENTION:

replacing the memory must be carried out after disconnecting all electrical connection of the P.C.B.



3.7 TROUBLESHOOTING.

Maintenance operations must be carried out by an authorised company (e.g. Authorised After-Sales Technical Assistance Service).



- **Smell of gas.** Caused by leakage from gas circuit pipelines. Check sealing efficiency of gas intake circuit.
- **Repeated ignition blocks.** No gas, check the presence of pressure in the network and that the gas adduction cock is open.
- **Irregular combustion or noisiness.** It may be caused by: a dirty burner, incorrect combustion parameters, intake-exhaust terminal not correctly installed. Check the above components.

- **Non-optimal ignition of first ignitions of the burner.** Even if the burner is perfectly calibrated, first ignition of the burner (after calibration) can be sub-optimal; the system automatically regulates ignition until it finds optimal ignition of the said burner.

- **Frequent trips of the overheating safety device thermostat function.** It can depend on the lack of water in the boiler, little water circulation in the system (or blocked pump, see *Par. 1.27*). Check on the pressure gauge that the system pressure is within established limits. Check that the radiator valves are not closed and also the functionality of the pump.

- **Siphon blocked.** This may be caused by dirt or combustion products deposited inside. Check that there are no residues of material blocking the flow of condensate.

- **Heat exchanger blocked.** This may be caused by the drain trap being blocked. Check that there are no residues of material blocking the flow of condensate.

- **Noise due to air in the system.** Check opening of the special air vent valve cap (Part. 23 Fig. 32). Make sure the system pressure and expansion vessel pre-charge values are within the set limits. The factory-set pressure values of the expansion vessel must be 1.0 bar, the value of system pressure must be between 1 and 1.2 bar.

- **Noise due to air inside the condensation module.** Use the manual air vent valve (Part. 23 Fig. 32) to eliminate any air present in the condensation module. When the operation has been performed, close the manual vent valve.

- **Poor production of D.H.W.** If a drop in performance is detected during supply of D.H.W., it is possible that the condensation module or D.H.W. heat exchanger is clogged. In this case, contact Immergas After-Sales Assistance Service that has procedures to clean the module or D.H.W. heat exchanger.

SGV 100 B&P GAS valve

Key:

- 1 - Gas valve outlet pressure point
- 2 - Coil
- 3 - Wiring connector
- 4 - Gas valve inlet pressure point
- 5 - P. Ref.

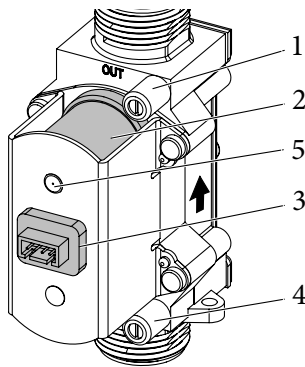

38

P.C.B.

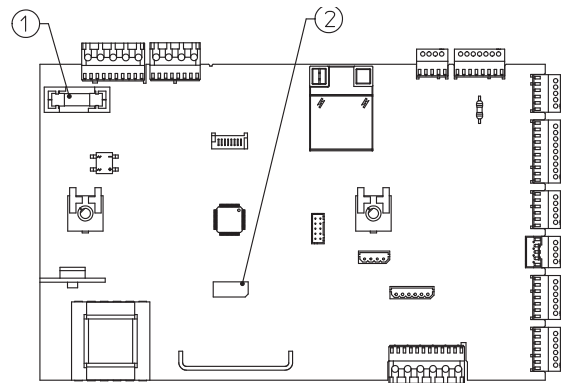

Key:

- 1 - Fuse 3.15 AF
- 2 - Removable memory (A19)

39

Red pump LED.

There can be three possible causes for this anomaly:

- **Low power supply voltage.** When the minimum voltage is reached after about 2 seconds, the LED switches from green to red and the pump stops. Wait for the power supply voltage to rise; when the pump restarts, the LED will turn green again with a delay of about one second.

Note: obviously the flow rate decreases as the supply voltage decreases.

- **Rotor seized.** Powering the pump with the rotor seized, after about 4 seconds the LED switches from green to red. Carefully act on the screw in the middle of the head to manually release the crankshaft; circulation starts up immediately after the rotor is released and the LED switches from red to green after about 10 seconds.

- **Electrical error.** Pump, wiring or P.C.B. fault. Check the indicated components.

3.8 CONVERTING THE BOILER TO OTHER TYPES OF GAS.

The gas conversion operation must be carried out by an authorised company (e.g. Authorised Technical After-Sales Service).



To convert to another type of gas the following operations are required:

- Select, via programming menu “G”, the type of gas by selecting “nG” for methane gas and “LG” for LPG gas. (Par. 3.15).

- Carry out complete calibration (Par. 3.11); during the procedure check and, if necessary, correct the CO₂ value.

- Upon completing the conversion, apply the sticker regarding the modified gas content onto the data nameplate in the connection box.

These adjustments must be made with reference to the type of gas used, following that given in the table (Par. 4.1).

3.9 CHECKS FOLLOWING CONVERSION TO ANOTHER TYPE OF GAS.

After having made sure that the conversion is complete and that the calibration has been successful, you must make sure that:

- there is no flame in the combustion chamber;
- the burner flame is not too high or low and that it is stable (does not detach from burner);
- the pressure testers used for calibration are perfectly closed and there are no leaks from the gas circuit.

Maintenance operations must be carried out by an authorised company (e.g. Authorised After-Sales Technical Assistance Service).



3.10 CALIBRATION TYPE INVOLVING THE REPLACEMENT OF A COMPONENT.

When performing extraordinary maintenance on the boiler, involving the replacement of a component, such as the P.C.B. (if the removable memory is not put into the replacement board) or components in the air, gas and flame control circuits, the boiler will need to be calibrated.

Select the type of calibration to be carried out according to the table below.

Replaced component	Type of calibration required
Gas valve	Quick calibration
Fan	Quick calibration
Burner	Complete calibration with CO ₂ check
Ignition/detection electrodes	Complete calibration with CO ₂ check
P.C.B. (New virgin P.C.B. without removable memory recovery)	Restore the parameters as described in the paragraph "P.C.B. programming" Complete calibration with CO ₂ check
P.C.B. (Recovery of the removable memory with the boiler parameters set from the replaced board)	No calibration required.

3.11 COMPLETE CALIBRATION FUNCTION.

N.B.: before carrying out complete calibration, ensure that all the requirements indicated in Par. 1.23 and 1.24 have been met.

In the event of anomaly "62" or "72" (Par. 2.5) the boiler cancels any requests by itself.

N.B.: During the various calibration stages, the CO₂ value can be checked and possibly corrected as described in (Par.3 12).

The energy produced is dissipated via the heating circuit; alternatively, the energy can be released from the DHW circuit by opening any hot water tap.

ATTENTION:

in this case the only active temperature control is the flow probe that limits the maximum temperature exiting the boiler at 90°C, therefore be careful not to get burned.



- The calibration procedure involves various stages:
 - nominal heat output calibration;
 - intermediate heat output ignition calibration;
 - minimum heat output calibration;
 - calibration self-check.

Each calibration procedure, if carried out without altering the parameters, lasts 5 minutes at the most, after which it switches automatically to the next parameter until the calibration process is complete.

In order to access the complete calibration stage, you must switch the boiler on, set the DHW selector in the "6 o'clock" position and the heating selector in the "9 o'clock" position, (Fig. 40) and press the "RESET" button for about 8 seconds until the "chimney sweep" function is activated; then press the "🔧" button within 3 seconds. If the temperature read from the storage tank during this phase is below 60 °C, the boiler can be switched on. Follow

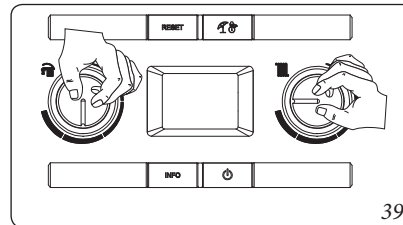

the operations described to start calibration.

If the energy produced in the central heating circuit needs to be discharged, turn the selector to 0 after the calibration function is enabled.

- **Nominal heat output:** with the function active, the boiler carries out the procedures required to calibrate the appliance at the nominal heat output.

At this stage, the display features flashing icons: "🔧", "🔌", "🔌" and the operating temperature alternated with the current operating heat output (99%);

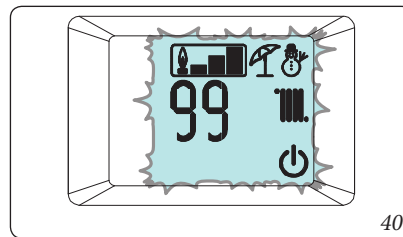

once the parameters are detected and stabilised, the frame of the flame presence symbol will start flashing (🔌) (this procedure may last a few minutes), meaning that the nominal heat output parameters have been set.

It is only possible to correct the CO₂ (Par. 3.12) value after the flame presence (🔌) frame flashes, or switch to the next heat output parameter by pressing the "INFO" button.

- **Intermediate heat output ignition:** once the nominal heat output calibration is confirmed, the boiler is calibrated with the intermediate heat output (or ignition heat output).

At this stage, the display features flashing icons: "🔧", "🔌", "🔌" and the operating temperature alternated with the current operating heat output (typically 41% but variable according to the boiler model);

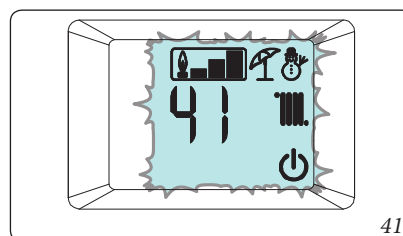



once the parameters are detected and stabilised, the frame of the flame presence symbol (🔌) will start flashing, meaning that the intermediate heat output parameters have been set.

It is only possible to correct the CO₂ (Par. 3.12) value after the flame presence (🔌) frame flashes, or switch to the next heat output parameter by pressing the "INFO" button.

- **Minimum heat output:** after having calibrated the boiler with the intermediate heat output, it is calibrated with the minimum heat output.

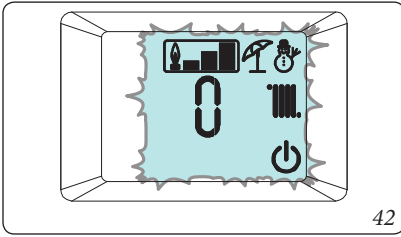
At this stage, the display features flashing icons: “↑”, “⊛”, “⏻” and the operating temperature alternated with the current operating heat output (0%);



once the parameters are detected and stabilised, the frame of the flame presence symbol () will start flashing, meaning that the minimum heat output parameters have been set.

If it is only possible to correct the CO₂ (Par. 3.12) value after the flame presence frame () flashes, or exit the calibration phase by pressing “↑”.

- **Calibration self-check:** once calibration operations are complete, the boiler runs a self-check for about one minute. During this check, the boiler can run at different powers and it is not possible to apply modifications to the operating parameters or to delete the operation in progress. Moreover, it is important not to cut the boiler's power.

3.12 CO₂ ADJUSTMENT.

During complete calibration (Par. 3.11), you can modify the values of CO₂.

To have an exact value of CO₂ in the flue, the technician must insert the sampling probe to the bottom of the sample point, then check that the CO₂ value is that specified in the table (Par. 3.3). If otherwise, change the value as described hereunder:

- during calibration, when the frame of the flame presence starts flashing () (indicating the correct acquisition of the parameters) it is possible to alter the CO₂ value by pressing the “RESET” button.

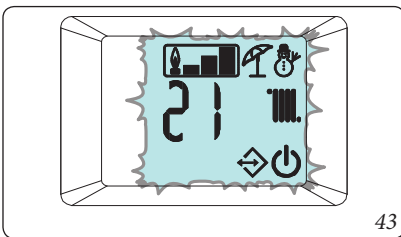

At this stage, the display features flashing icons: “↑”, “⊛”, “⏻”, “⏪”, “⏩” and display of the operating temperature is alternated with the set combustion.

- To increase the combustion setting, press button “⏻”; to decrease it, press the “INFO”. As the combustion setting increases, the CO₂ value decreases and vice-versa.
- Once the parameter has been altered wait for the value to be saved (displayed via the frame of the flame presence symbol flashing ).
- To confirm the set value press “RESET”.

3.13 FAST CALIBRATION.

This function allows you to calibrate the boiler automatically without requiring or giving the possibility to alter the parameters. Typically “fast calibration” is used after having set the type of flue in menu “F”, which once altered causes anomaly “72”.

N.B.: before performing quick calibration, ensure that all the requirements indicated in (Par. 1.23 and 1.24).

N.B.: to access this function it is crucial that there are no active requests for central heating or DHW production.

In the event of anomaly “62” or “72” (Par. 2.5) the boiler cancels any requests by itself.

The energy produced is dissipated via the heating circuit; alternatively, the energy can be released from the DHW circuit by opening any hot water tap.

ATTENTION:

in this case the only active temperature control is the flow probe that limits the maximum temperature exiting the boiler at 90°C, therefore be careful not to get burned.



In order to access the fast calibration stage, set the DHW selector in the “6 o'clock” position and the heating selector in the “9 o'clock” position, (Fig. 45) and press the “RESET” button for about 8 seconds until the “chimney sweep” function is activated; then press the “INFO” button within 3 seconds. If the temperature read from the storage tank during this phase is below 60 °C, the boiler can be switched on.

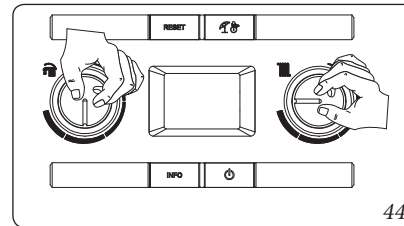

If the energy produced in the central heating circuit is to be discharged, turn the selector to “0” after the calibration function is enabled.

Once the quick calibration function is active, the boiler sequentially carries out the procedures required to calibrate the appliance with the nominal, intermediate and minimum heat output values.

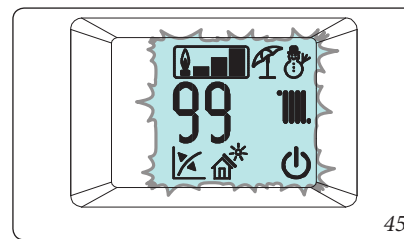

At this stage, the display features flashing icons: “↑”, “⊛”, “⏻” and “⏪” and the operating temperature will be displayed, alternated with the current operating heat output.

The calibration stages (nominal, intermediate and minimum) progress automatically and you must wait until calibration is complete.

3.14 FLUE TEST.

To define the value to set in the "flue length" "F0" parameter, detect the parameters during the "flue test".

N.B.: before performing the test, ensure that the condensate drain trap has been filled correctly and check that there are no obstructions in the air intake circuit and flue exhaust and that the sealed chamber is perfectly closed and the flue has already been installed.

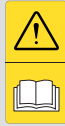

Once the test has been carried out properly, note the detected value in the relevant table, in order to have it available for future checks.

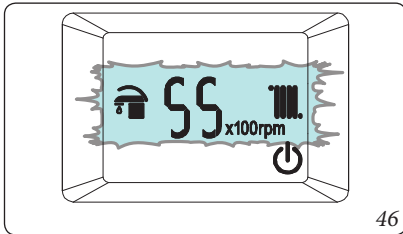

To activate this mode, the boiler must be in "stand-by" mode, which is visible when the (power button icon) symbol appears.

N.B.: if the boiler is connected to the CAR^{v2} the "stand-by" function can only be activated via the remote control panel.

To activate the function, press the buttons "RESET" and (power button icon) simultaneously until function activation, which is displayed by indicating the fan operation speed (in hundreds of revs) and ignition of the flashing "D.H.W." (DHW icon) and "central heating" (radiators icon) symbols.

The appliance remains in this mode for a maximum period of 15 minutes, keeping the fan speed constant.

This function ends once 15 minutes have elapsed, or by disconnecting supply voltage to the boiler, or by pressing the (power button icon) button for approximately 8 seconds.

Check the ΔP between the two pressure test outlets (Ref. 13 Fig. 32) according to the values shown in the tables below:

Victrix Zeus 25 - 32	
Parameter F0	Pressure
0	< 90 Pa
1	90 ÷ 120 Pa
2	120 ÷ 150 Pa
Value detected on first check	

N.B.: examinations are carried out by sealing the holes provided to analyse the flues, making them pneumatically sealed.

N.B.: should there be a boiler malfunction, you can carry out a flue test to check that there are no obstructions in the flue system. Different values to those indicated in the previous tables indicate a flue system malfunction, especially a flue system with excessive load losses or obstructed system.

3.15 PROGRAMMING THE P.C.B.

The boiler is prepared for possible programming of several operation parameters. By modifying these parameters as described below, the boiler can be adapted according to specific needs.

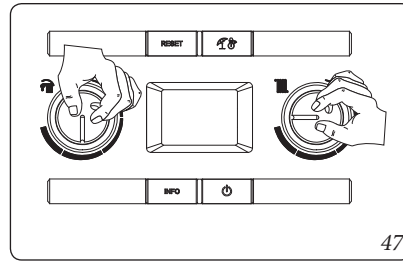

To access the programming stage, set the DHW selector in the "6 o'clock" position and the heating selector in the "9 o'clock" position and press the "RESET" and "DHW" (Fig. 48) buttons

for about 8 seconds. Once the programming mode has been accessed, scroll through the five menus (G, P, t, A, F) by pressing the "DHW" button for 1 second.

Use the "D.H.W. regulator" selector to select the parameter (within the same sub-menu and when several parameters are available) and turn the "C.H. regulator" selector to alter the value.

Press the "RESET" button (3) for 1 second to memorise the variation of the parameters.

Memorisation is represented via "88" on the indicator (Ref. 14 Fig. 14 Fig. 33) for 2 seconds.

Exit the programming mode by waiting for 15 minutes or by pressing the "RESET" and "DHW" buttons at the same time.

ATTENTION:

if necessary the default values relating to parameters "S" and "P0 ÷ P2" can be altered by temporarily modifying the type of gas (parameter "G") and by restoring it according to the actual operating conditions (wait for approximately 10 seconds between the gas change and the when it is restored).

The restored values will be those relating to the type of boiler set in parameters "n" and "F".

At the end of this operation, anomaly "E62" will appear and complete calibration will be required.

- **Menu "G".** This menu is reserved for the air-gas control settings and it features two sub-menus (n and S), relating to fan and gas valve control settings. Every time these parameters are altered, the complete calibration function must be activated (Par. 3.11).

In order to access parameters “n” and “S” press the “RESET” button sequentially. In order to exit this part of the menu and access other parts (categories P, t, A, F) press the “” button.

- **IL.** The “IL” gas type is not used; to exit, press “”. If the “IL” GAS is memorised, you must memorise the correct type of GAS again.

Id Parameter	Parameter	Description	Range	Default	Customised value
G	Gas type	Defines operation with methane gas	nG	nG	
		Defines operation with LPG gas	LG		
		Not used	IL		
In the event of an alteration, anomaly “E62” appears and complete calibration is required.					

Id Parameter	Parameter	Description	Range	Default	Customised value
n	Boiler model	Define the boiler model	0 ÷ n	Victrix 25:16 Victrix 32:15	
Caution: only use the parameter relating to the boiler installed. In the event of an alteration, anomaly “E62” appears and complete calibration is required.					

Id Parameter	Parameter	Description	Range	Default	Customised value
S0	Min output	The P.C.B. defines the operating mode and the boiler output according to the combination of several parameters. The proper operating output of the appliance is defined according to the combination of the parameters of menus “n” and “F”. For this reason it is recommended not to alter the parameters of this menu in order not to compromise the proper operation of the boiler.	750 ÷ 1700 rpm	Victrix 25: 1150 Victrix 32: 1100	
S1	Max output		S0 ÷ 6900 rpm	Victrix 25: 3200 Victrix 32: 3000	
S2	Ignition output		2000 ÷ 4500 rpm	Victrix 25: 6200 Victrix 32: 6200	
In the event of an alteration, anomaly “E62” appears and complete calibration is required.					

Id Parameter	Parameter	Description	Range	Default	Customised value
P0	DHW max	Defines the maximum heat output percentage of the boiler during the D.H.W. phase compared to the maximum heat output available	0 - 99 %	99%	
P1	Min output	Defines the minimum heat output percentage of the boiler compared to the minimum heat output available	0 - P2	0%	
P2	Central heating max	Defines the maximum heat output percentage of the boiler during the central heating mode compared to the maximum heat output available	0 - 99%	Victrix 25: 80% Victrix 32: 85%	
P3	Relay 1 (optional)	The boiler is set-up for functioning with the relay board (optional), which can be configured 0 = Off 1 = Main zone control 2 = General alarm 3 = CH mode active 4 = External gas valve power supply 5 = (Do not use on this boiler model) 6 = (Do not use on this boiler model) 7 = (Do not use on this boiler model)	0 - 7	1	
P4	Relay 2 (optional)	The boiler is set-up for functioning with the relay board (optional), which can be configured 0 = Off 1 = General alarm 2 = CH phase mode 3 = External gas valve power supply 4 = Secondary zone control (from TA on relay board contact) 5 = Heat pump 6 = (Do not use on this boiler model) 7 = (Do not use on this boiler model)	0 - 7	0	

P5	Relay 3 (optional)	The boiler is set-up for functioning with the relay board (optional), which can be configured 0 = Off 1 = Chiller remote activation 2 = General alarm 3 = CH mode active 4 = External gas valve power supply 5 = heat pump 6 = Storage tank activation with recirculation 7 = Main zone control 8 = (Do not use on this boiler model) 9 = (Do not use on this boiler model).	0 - 9	0	
P6	Pump functioning	The pump can function in two ways. 0 intermittent: in winter "mode" the circulator is managed by the room thermostat or by the remote control 1 continuous: in "winter" mode the circulator is always powered and is therefore always in operation	0 - 1	0	
P7	External probe correction	If the reading of the external probe is not correct it is possible to correct it in order to compensate any environmental factors. (Over the value of +9 the display shows "CE", which enables an external control function of the boiler for coupling of the same with a system supervisor)	-9 ÷ 9 K	0	
P8	-	Not used on this boiler model	-	-	

INSTALLER

USER

t0	Central heating set point minimum temperature	Defines the minimum flow temperature.	20 ÷ 50 °C	25	
t1	Central heating set point maximum temperature	Defines the maximum flow temperature.	(t0+5) ÷ 85 °C	85	
t2	D.H.W. thermostat	Defines the flow temperature during the storage tank central heating phase 0 : Flow temperature = Set DHW + 25°C 1 : Flow temperature depends on the boiler's power 2 : Flow temperature = 1.1*Set DHW + 6°C 3 : Flow temperature = 85°C	0 - 3	1	
t3	Solar delay timing	Not used	-	-	
t4	Domestic hot water priority timing	Not used	-	-	
t5	Central heating ignitions timer	The boiler has an electronic timer, which prevents the burner from igniting too often in central heating mode	0 - 600 seconds (step 10 sec)	18	
t6	Central heating ramp timer	In central heating mode, the boiler performs an ignition ramp in order to reach the maximum output set	0 - 840 seconds (step 10 sec)	18	
t7	CH ignition delay from TA and CR request	The boiler is set to switch-on immediately after a request. In the event of particular systems (e.g. area systems with motorised thermostatic valves etc.) it may be necessary to delay ignition	0 - 600 seconds (step 10 sec)	0	

MAINTENANCE TECHNICIAN

t8	Display lighting	Establishes the display lighting mode. 0 Automatic: the display lights up during use and dims after 15 seconds of inactivity. In the event of an anomaly the display flashes. 1 Low: the display is always lit with low intensity 2 High: the display is always lit with high intensity.	0 - 2	0	
t9	Display	Establishes what the indicator displays 14 (Fig. 33). "Summer" mode: 0: the indicator is always off 1: pump active displays the flow temperature, pump off the indicator is off "Winter" mode: 0: always displays the value set on the CH selector 1: pump active displays the flow temperature, pump off always displays the value set on the CH selector	0 - 1	1	

Id Parameter	Parameter	Description	Range	Default	Customised value
A0	Hydraulic model	Defines the type of hydraulics in the boiler	Set 2	2	
A1	-	Not used on this boiler model	-	0	
A2	Model Pump	Defines the type of circulator in the boiler	Set 3	3	
A3	Maximum pump speed	Sets the maximum pump operating speed	1 ÷ 9	9	
A4	Minimum pump speed	Sets the minimum pump operating speed	1 ÷ A3	6	
A5	Pump operating mode	Sets the pump operating mode - DELTA T = 0: proportional head (see (Parag. 1.27-1.28) - DELTA T = 5 ÷ 25 K: ΔT constant (Parag. 1.27-1.28)	0 ÷ 25	15	
A7	Ignition phase automatic vent	Sets the activation mode of the automatic vent at each new electric powering phase of the boiler. This function lasts 8 minutes, and is displayed via a countdown signalled by the special indicator (Ref. 14 Fig. 33). During this period the DHW and CH functions are not active. The "automatic vent" function can be annulled by pressing the "RESET" button. 1: the automatic vent is enabled at each new electric power supply. 0: the automatic vent is enabled only at the first electric power supply after having set the parameter to "0"; once the function has ended, or is interrupted by pressing the "RESET" button, it will not be enabled again unless the parameter is set to "1".	0 - 1	1	

Id Parameter	Parameter	Description	Range	Default	Customised value
F0	Length flue	Defines the length of the flue (Par. 3.14)	0 - 2	0	
F1	-	Not used on this boiler model	-	0	

In the event of an alteration, anomaly "E72" appears and fast calibration is required.

3.16 "CHIMNEY SWEEP" FUNCTION.



When activated, this function forces the boiler to variable output for 15 minutes.

In this state all adjustments are excluded and only the safety thermostat and the limit thermostat remain active. To activate the chimney sweep function, press the "RESET" button until activation of the function in the absence of DHW requests.

Its activation on the boiler display is confirmed by indicators "I" and "E" flashing at the same time, while on the CAR^{V2} (optional) it is reported as "ERR>07".

This function allows the technician to check the combustion parameters.

Once the function is activated, it is possible to select whether to make the check in CH status or DHW status by opening any hot water cock and regulating the power by turning the "CH regulation" selector (6).

The central heating or DHW operating mode is displayed by the relative symbols  or .

After the checks, deactivate the function switching the boiler off and then on again.

Attention: the boiler needs a certain amount of time to stabilise itself before carrying out a combustion parameters check. It is thus necessary to wait for the boiler to carry out a self-diagnosis test, which is signalled by the  flashing symbol. Once the symbol stops flashing, it is possible to check the combustion parameters.

3.17 PUMP ANTI-BLOCK FUNCTION.

The boiler has a function that starts the pump at least once every 24 hours for the duration of 30 seconds in order to reduce the risk of the pump becoming blocked due to prolonged inactivity.

3.18 THREE-WAY ANTI-BLOCK SYSTEM.

Both in "domestic hot water" and in "domestic hot water-central heating" phase the boiler is equipped with a function that starts the three-way motorised group 24 hours after it was last in operation, running it for a full cycle so as to reduce the risk of the three-way group becoming blocked due to prolonged inactivity.

3.19 RADIATORS ANTIFREEZE FUNCTION.

If the system return water is below 4°C, the boiler starts up until reaching 42°C.

3.20 PERIODICAL P.C.B. SELF-CHECK.

During functioning in central heating mode or with boiler in standby, the function activates every 18 hours after the last boiler check/power supply. In case of functioning in domestic hot water mode the self-check starts within 10 minutes after the end of the withdrawing in progress, for duration of approx. 10 seconds.

N.B.: during self-check, the boiler remains off.

3.21 AUTOMATIC VENT FUNCTION.

In the case of new central heating systems and in particular mode for floor systems, it is very important that deaeration is performed correctly. The function consists of the cyclic activation of the pump (100 s ON, 20 s OFF) and the 3-way valve (120 s D.H.W., 120 s C.H.).

The function is activated in two different ways:

- at each new boiler power supply, based on the setting of parameter "A7";
- by pressing buttons "I" and "INFO" at the same time for 5 seconds with boiler in stand-by.

N.B.: if the boiler is connected to the CAR^{V2} the "stand-by" function can only be activated via the remote control panel.

In the first case, the function has duration of 8 minutes and it can be interrupted by pressing the "RESET" button (18). In the second case it has duration of 18 hours and it can be interrupted by simply switching the boiler on.

Activation of the function is signalled by the countdown shown on the indicator (Ref. 14 Fig. 33).

3.22 CASING REMOVAL.

To facilitate boiler maintenance the casing can be completely removed as follows:

• Lower grid (Fig. 49).

- 1) Loosen the two screws (a).
- 2) remove the grid (b).

• Front panel (Fig. 50).

- 3) Remove the cover caps (c) and loosen screws (d).
- 4) Loosen the two screws (e) secured under the hinges.
- 5) Pull the front panel (f) towards you and release it from its lower seat.

• Front (Fig. 51).

- 6) Loosen the two screws (g).
- 7) Pull the front (f) slightly towards you.
- 8) Release the front (f) from the bracket (h) by pushing upwards and towards you.

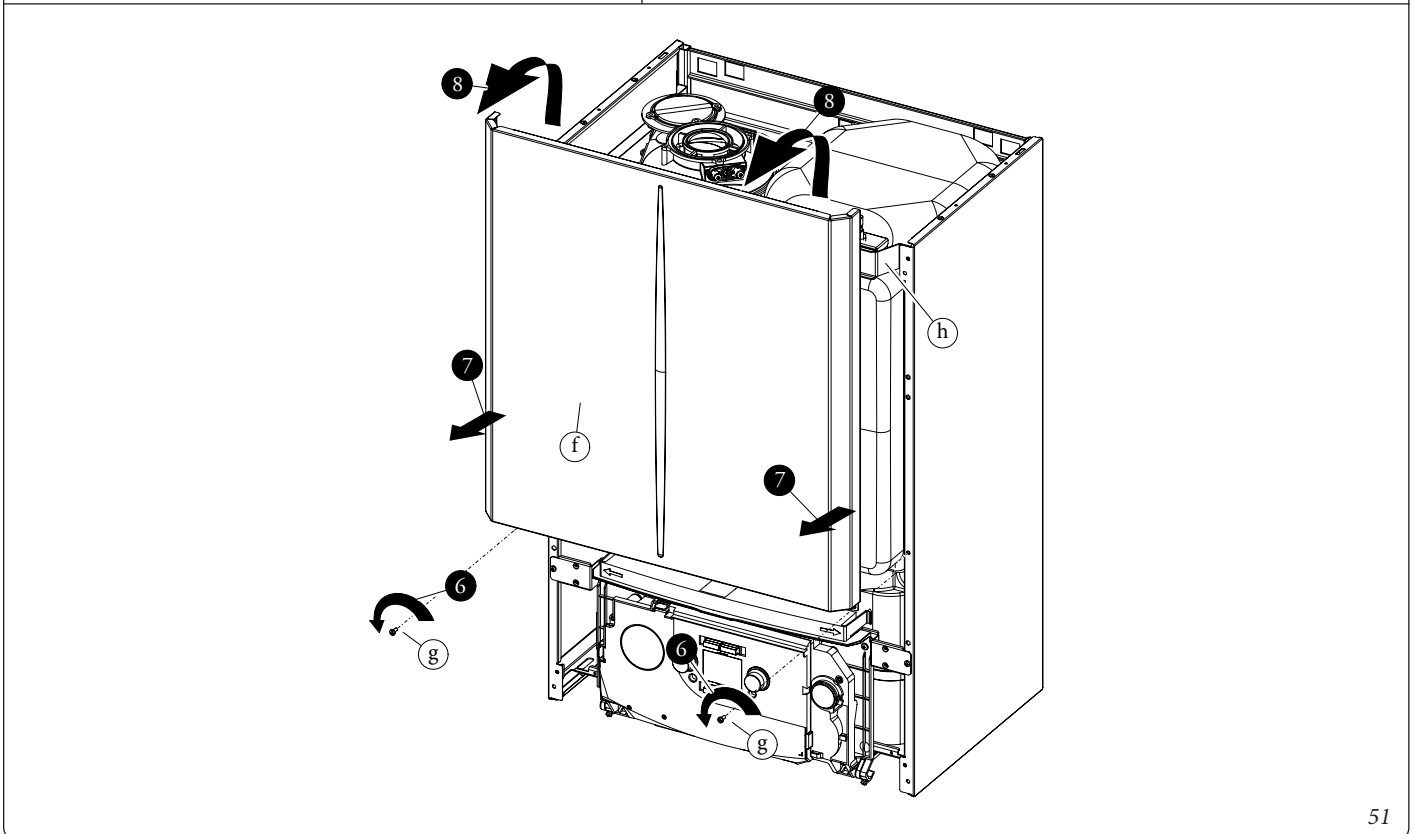
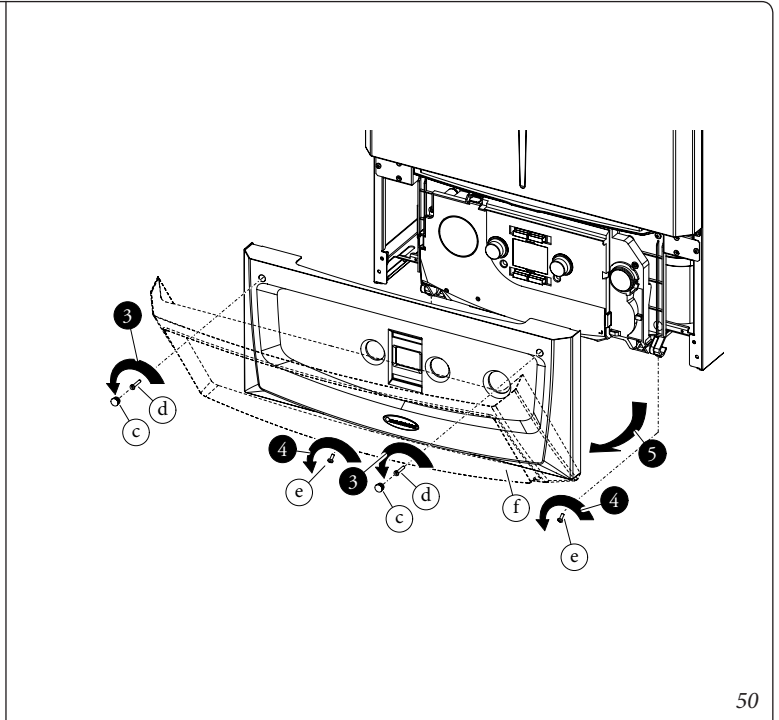
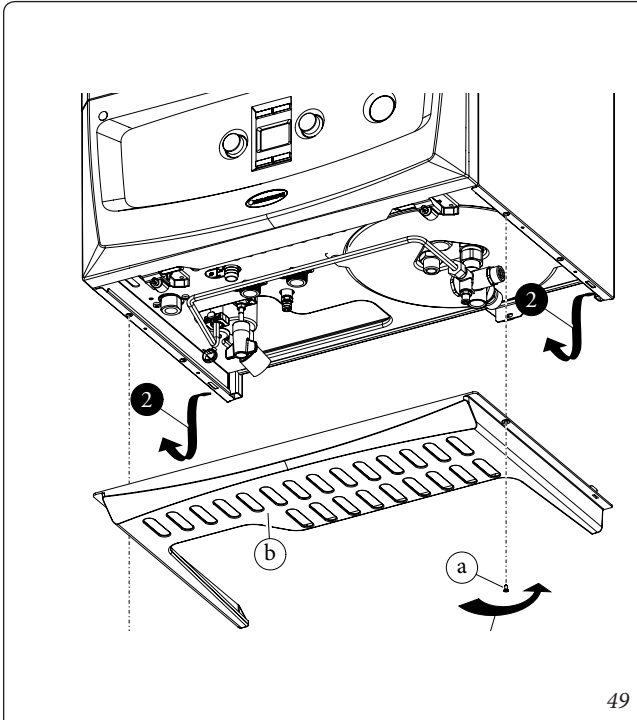

• Control panel (Fig. 52).

- 9) Loosen the fixing screws (i) from the front panel.
- 10) Press the hooks on the side of the control panel.
- 11) Tilt the control panel (j) towards you.

• Sides (Fig. 53).

- 12) Unscrew the side (k) fastening screws (l).
- 13) Remove the sides by extracting them from their rear seat (Ref. X).

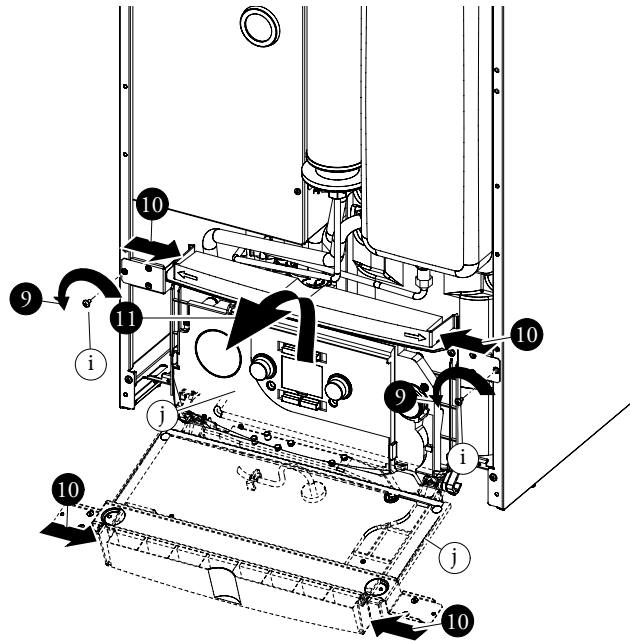

52

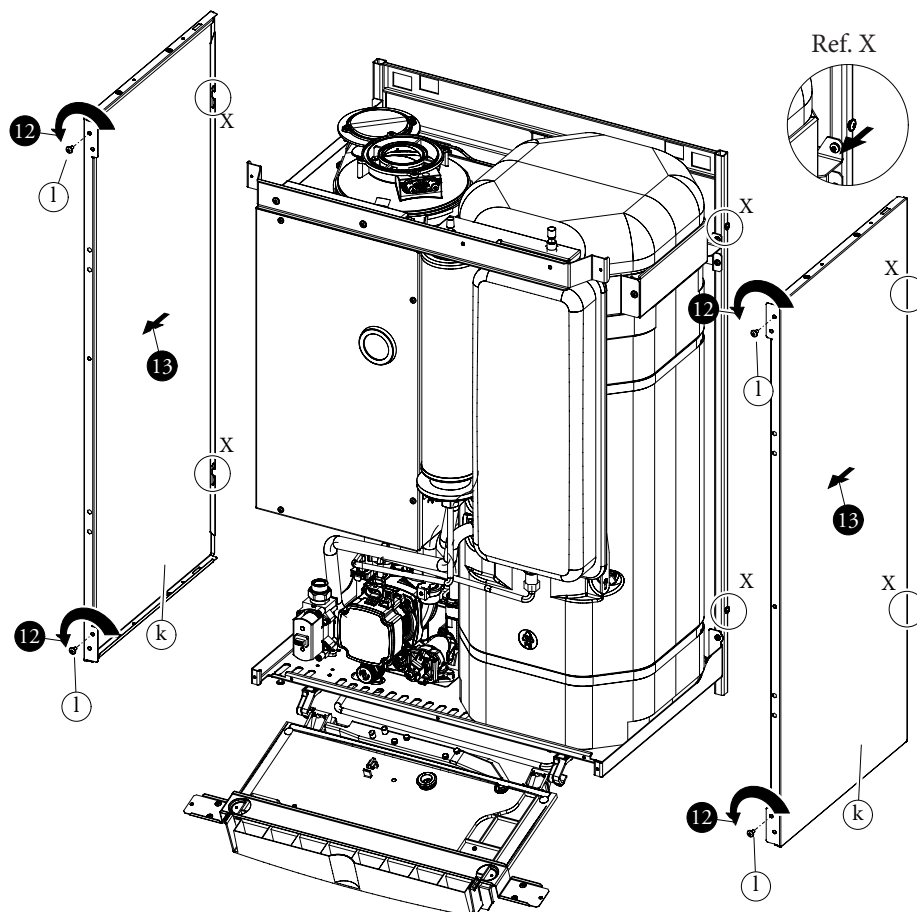

53

INSTALLER

USER

MAINTENANCE TECHNICIAN

4 TECHNICAL DATA.

haust pipe measuring 0.5 m in length. Gas flow rates refer to net calorific value below a temperature of 15°C and at a pressure of 1013 mbar.

4.1 VARIABLE HEAT OUTPUT.

N.B.: the power data in the table has been obtained with intake-ex-

Victrix Zeus 25.

HEAT THERMAL			METHANE (G20)		PROPANE (G31)	
			MODULATION	GAS FLOW RATE BURNER	MODULATION	GAS FLOW RATE BURNER
(kW)	(kcal/h)		(%)	(m ³ /h)	(%)	(kg/h)
25.0	21500	D.H.W.	99	2.73	99	2.00
24.0	20640		95	2.62	95	1.92
23.0	19780		91	2.51	91	1.84
22.0	18920		88	2.40	88	1.76
21.0	18060		84	2.29	84	1.68
20.0	17200	HEAT. + D.H.W.	80	2.18	80	1.60
19.0	16340		76	2.07	76	1.52
18.0	15480		71	1.96	71	1.44
17.0	14620		67	1.85	67	1.36
16.0	13760		63	1.75	63	1.28
15.0	12900		59	1.64	59	1.20
14.0	12040		54	1.53	54	1.12
13.0	11180		50	1.42	50	1.04
12.0	10320		45	1.31	45	0.96
11.0	9460		40	1.21	40	0.89
10.0	8600		35	1.10	35	0.81
9.0	7740		30	0.99	30	0.73
8.0	6880		25	0.88	25	0.65
7.0	6020		20	0.77	20	0.57
6.0	5160		15	0.66	15	0.49
5.0	4300		10	0.56	10	0.41
4.0	3440		4	0.45	4	0.33
3.5	3010	2	0.39	2	0.29	

Victrix Zeus 32.

VARMEYDELSE			METAN (G20)		PROPAN (G31)	
			MODULERING	GASMÆNGDE BRÆNDER	MODULERING	GASMÆNGDE BRÆNDER
(kW)	(kcal/h)		(%)	(m ³ /h)	(%)	(kg/h)
32.0	27520	BRUGSV.	99	3.50	99	2.57
31.0	26660		96	3.39	96	2.49
30.0	25800		93	3.28	93	2.41
29.0	24940		89	3.18	89	2.33
28.0	24080		85	3.07	85	2.25
27.0	23220	OPVARM. + BRUGSV.	82	2.96	82	2.17
26.0	22360		77	2.85	77	2.09
25.0	21500		73	2.74	73	2.01
24.0	20640		69	2.63	69	1.93
23.0	19780		65	2.52	65	1.85
22.0	18920		60	2.42	60	1.77
21.0	18060		56	2.31	56	1.69
20.0	17200		51	2.20	51	1.61
19.0	16340		47	2.09	47	1.53
18.0	15480		43	1.98	43	1.46
17.0	14620		39	1.87	39	1.38
16.0	13760		36	1.77	36	1.30
15.0	12900		32	1.66	32	1.22
14.0	12040		29	1.55	29	1.14
13.0	11180		26	1.44	26	1.06
12.0	10320		23	1.34	23	0.98
11.0	9460		20	1.23	20	0.90
10.0	8600	17	1.12	17	0.82	
9.0	7740	14	1.01	14	0.74	
8.0	6880	11	0.90	11	0.66	
7.0	6020	8	0.79	8	0.58	
6.0	5160	6	0.68	6	0.50	
5.0	4300	3	0.57	3	0.42	
4.0	3440	1	0.45	1	0.33	

4.2 COMBUSTION PARAMETERS.

		G20	G31
Supply pressure	mbar (mm H ₂ O)	20 (204)	37 (377)
Victrix Zeus 25			
Gas nozzle diameter	mm	5.00	5.00
Flue flow rate at nominal DHW/heat output	kg/h (g/s)	42 (11.67) - 34 (9.45)	43 (11.94) - 34 (9.45)
Flue flow rate at min heat output	kg/h (g/s)	6 (1.67)	6 (1.67)
CO ₂ at Q. Nom./Acc./Min.	%	9.20 / 9.00 / 9.00 (± 0.2)	10.20 / 10.00 / 10.00 (± 0.2)
CO with 0% O ₂ at Nom./Min. Q.	ppm	240 / 7	263 / 7
NO _x with 0% O ₂ at Nom./Min. Q.	mg/kWh	72 / 27	39 / 34
Flue temperature at nominal output	°C	63	63
Flue temperature at minimum output	°C	54	54
Max air combustion temperature	°C	50	50
Intake / exhaust available head F0 = 0	Pa	68	68
Intake / exhaust available head F0 = 1	Pa	103	103
Intake / exhaust available head F0 = 2	Pa	138	138
Victrix Zeus 32			
Gas nozzle diameter	mm	5.30	5.30
Flue flow rate at nominal DHW/heat output	kg/h (g/s)	53 (14.72) - 47 (13.05)	55 (15.27) - 48 (13.33)
Flue flow rate at min heat output	kg/h (g/s)	7 (1.95)	7 (1.95)
CO ₂ at Q. Nom./Acc./Min.	%	9.20 / 9.00 / 9.00 (± 0.2)	10.20 / 10.00 / 10.00 (± 0.2)
CO with 0% O ₂ at Nom./Min. Q.	ppm	191 / 2	199 / 2
NO _x with 0% O ₂ at Nom./Min. Q.	mg/kWh	46 / 23	50 / 31
Flue temperature at nominal output	°C	64	64
Flue temperature at minimum output	°C	55	55
Max air combustion temperature	°C	50	50
Intake / exhaust available head F0 = 0	Pa	93	93
Intake / exhaust available head F0 = 1	Pa	148	148
Intake / exhaust available head F0 = 2	Pa	250	250

Combustion parameters: measuring conditions of useful efficiency (flow temperature/return temperature= 80 / 60 °C), ambient temperature reference = 15°C.

4.3 TECHNICAL DATA TABLE.

		Victrix Zeus 25	Victrix Zeus 32
Domestic hot water nominal heat input	kW (kcal/h)	25,8 (22188)	33,1 (28430)
Central heating nominal heat input	kW (kcal/h)	20,6 (17705)	29,0 (24928)
Minimum heat input	kW (kcal/h)	3,7 (3172)	4,3 (3695)
Domestic hot water nominal heat output (useful)	kW (kcal/h)	25,0 (21500)	32,0 (27520)
Central heating nominal heat output (useful)	kW (kcal/h)	20,0 (17200)	28,0 (24080)
Minimum heat output (useful)	kW (kcal/h)	3,5 (3010)	4,0 (3440)
*Effective thermal efficiency 80/60 Nom./Min.	%	97,1 / 94,9	96,6 / 93,1
*Effective thermal efficiency 50/30 Nom./Min.	%	105,0 / 105,8	104,5 / 102,3
*Effective thermal efficiency 40/30 Nom./Min.	%	106,9 / 107,7	106,3 / 106,9
Casing losses with burner On/Off (80-60°C)	%	0,73 - 0,5	0,41 - 1,5
Chimney losses with burner On/Off (80-60°C)	%	0,04 - 2,6	0,01 - 1,7
Central heating circuit max. operating pressure	bar (MPa)	3,0 (0,3)	3,0 (0,3)
Maximum heating temperature	°C	90	90
Adjustable central heating temperature (min. operating field)	°C	20 - 50	20 - 50
Adjustable central heating temperature (max. operating field)	°C	25 - 85	25 - 85
Central heating System expansion vessel total volume	l	5,8	7,1
Central heating expansion tank pre-charge	bar (MPa)	1,0 (0,1)	1,0 (0,1)
Total volume domestic hot water expansion vessel	l	1,5	1,5
Domestic hot water expansion vessel pre-charge	bar (MPa)	2,5 (0,25)	2,5 (0,25)
Appliance water content	l	4,7	5,9
Head available with 1000 l/h flow rate	kPa (m H ₂ O)	26,31 (2,68)	30,80 (3,10)
Hot water production useful heat output	kW (kcal/h)	25,0 (21500)	32,0 (27520)
Domestic hot water adjustable temperature	°C	10 - 60	10 - 60
Domestic hot water circuit min. pressure (dynamic)	bar (MPa)	0,3 (0,03)	0,3 (0,03)
Domestic hot water circuit max. operating pressure	bar (MPa)	8,0 (0,8)	8,0 (0,8)
Flow rate capacity in continuous duty (ΔT 30°C)	l/min	12,0	15,1
Weight of full boiler	kg	105,4	121,9
Weight of empty boiler	kg	57,6	65,5
Electrical connection	V/Hz	230 / 50	230 / 50
Nominal power absorption	A	0,65	0,85
Installed electric power	W	88	120
Pump absorbed power	W	43	59
EEI value	-	≤ 0,20 - Part. 3	≤ 0,20 - Part. 3
Fan power absorbed power	W	33	49
Equipment electrical system protection	-	IPX5D	IPX5D
Max temperature of combustion products	°C	75	75
Max. flue overheating temperature	°C	120	120
Ambient operating temperature range	°C	0 ÷ + 40	0 ÷ + 40
Ambient operating temperature range with optional antifreeze kit	°C	-15 ÷ + 40	-15 ÷ + 40
NO _x class	-	6	6
Weighted NO _x	mg/kWh	39	38
Weighted CO	mg/kWh	21	19
**Type of appliance	C13 - C13x - C33 - C33x - C43 - C43x - C53 - C63 - C83 - C93 - C93x - B23 - B33 - B53		
Category	II 2H3P		

- The data relating to domestic hot water performance refer to a dynamic inlet pressure of 2 bar and an inlet temperature of 15°C; the values are measured immediately at the boiler outlet, considering that to obtain the data declared, mixing with cold water is required.

- * Efficiencies refer to the net calorific value.

- The weighted NO_x value refer to the net calorific value.

4.4 KEY FOR DATA NAMEPLATE.

Md		Cod. Md	
Sr N°	CHK	Cod. PIN	
Type			
Q _{nw} /Q _n min.	Q _{nw} /Q _n max.	P _n min.	P _n max.
PMS	PMW	D	TM
NO _x Class			
		CONDENSING	

Note: the technical data is provided on the data nameplate on the boiler

ENG	
Md	Model
Cod. Md	Model code
Sr N°	Serial Number
CHK	Check
Cod. PIN	PIN code
Type	Type of installation (ref. CEN TR 1749)
Q _{nw} min.	Minimum DHW heat input
Q _n min.	Central heating minimum heat input
Q _{nw} max.	DHW maximum heat input
Q _n max.	Central heating maximum heat input
P _n min.	Minimum heat output
P _n max.	Maximum heat output
PMS	Maximum system pressure
PMW	Maximum domestic hot water pressure
D	Specific flow rate
TM	Maximum operating temperature
NO _x Class	NO _x Class
CONDENSING	Condensing boiler

4.5 TECHNICAL PARAMETERS FOR COMBINATION BOILERS (IN COMPLIANCE WITH REGULATION 813/2013).

The efficiencies and NO_x values in the following tables refer to the gross calorific value.

Model/s:				Victrix Zeus 25				
Condensing Boilers:				YES				
Low temperature boiler:				NO				
Boiler type B1:				NO				
Co-generation appliance for central heating:				NO			Fitted with supplementary heating system:	NO
Mixed heating appliance:				YES				
Element	Symbol	Value	Unit	Element	Symbol	Value	Unit	
Nominal heat output	P _n	20	kW	Seasonal energy efficiency of central heating	η _s	92	%	
For central heating only and combination boilers: useful heat output				For central heating only and combination boilers: useful efficiency				
At nominal heat output in high temperature mode (*)	P ₄	20.0	kW	At nominal heat output in high temperature mode (*)	η ₄	87.3	%	
At 30% of nominal heat output in a low temperature mode (**)	P ₁	6.6	kW	At 30% of nominal heat output in a low temperature mode (**)	η ₁	97.0	%	
Auxiliary electricity consumption				Other items				
At full load	el _{max}	0.018	kW	Heat loss in standby	P _{stby}	0.104	kW	
At partial load	el _{min}	0.013	kW	Ignition burner energy consumption	P _{ign}	0.000	kW	
In standby mode	P _{SB}	0.005	kW	Emissions of nitrogen oxides	NO _x	35	mg / kWh	
For mixed central heating appliances								
Stated load profile		XL		Domestic hot water production efficiency	η _{WH}	81	%	
Daily electrical power consumption		Q _{elec}	0.208 kWh	Daily gas consumption	Q _{fuel}	24.106	kWh	
Contact information		IMMERGAS S.p.A. VIA CISA LIGURE, 95 - 42041 BRESCELLO (RE) ITALY						

(*) High temperature mode means 60°C on return and 80°C on flow.

(**) Low temperature mode for condensation Boilers means 30°C , for low temperature boilers 37°C and for other appliances 50°C of return temperature.

Model/s:				Victrix Zeus 32				
Condensing Boilers:				YES				
Low temperature boiler:				NO				
Boiler type B1:				NO				
Co-generation appliance for central heating:				NO			Fitted with supplementary heating system:	NO
Mixed heating appliance:				YES				
Element	Symbol	Value	Unit	Element	Symbol	Value	Unit	
Nominal heat output	P _n	28	kW	Seasonal energy efficiency of central heating	η _s	92	%	
For central heating only and combination boilers: useful heat output				For central heating only and combination boilers: useful efficiency				
At nominal heat output in high temperature mode (*)	P ₄	28.0	kW	At nominal heat output in high temperature mode (*)	η ₄	86.5	%	
At 30% of nominal heat output in a low temperature mode (**)	P ₁	9.4	kW	At 30% of nominal heat output in a low temperature mode (**)	η ₁	97.1	%	
Auxiliary electricity consumption				Other items				
At full load	el _{max}	0.021	kW	Heat loss in standby	P _{stby}	0.075	kW	
At partial load	el _{min}	0.013	kW	Ignition burner energy consumption	P _{ign}	0.000	kW	
In standby mode	P _{SB}	0.006	kW	Emissions of nitrogen oxides	NO _x	34	mg / kWh	
For mixed central heating appliances								
Stated load profile		XL		Domestic hot water production efficiency	η _{WH}	80	%	
Daily electrical power consumption		Q _{elec}	0.278 kWh	Daily gas consumption	Q _{fuel}	24.536	kWh	
Contact information		IMMERGAS S.p.A. VIA CISA LIGURE, 95 - 42041 BRESCELLO (RE) ITALY						

(*) High temperature mode means 60°C on return and 80°C on flow.

(**) Low temperature mode for condensation Boilers means 30°C , for low temperature boilers 37°C and for other appliances 50°C of return temperature.

4.6 PRODUCT FICHE (IN COMPLIANCE WITH REGULATION 811/2013).

Victrix Zeus 25

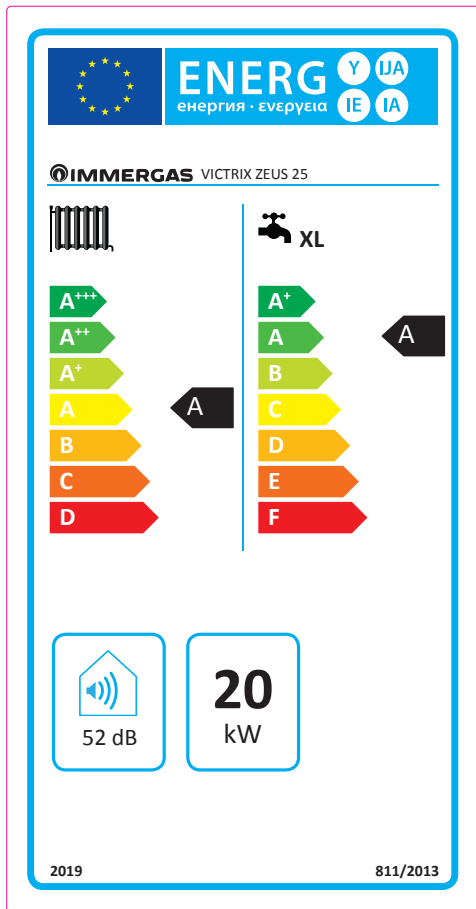

Victrix Zeus 32

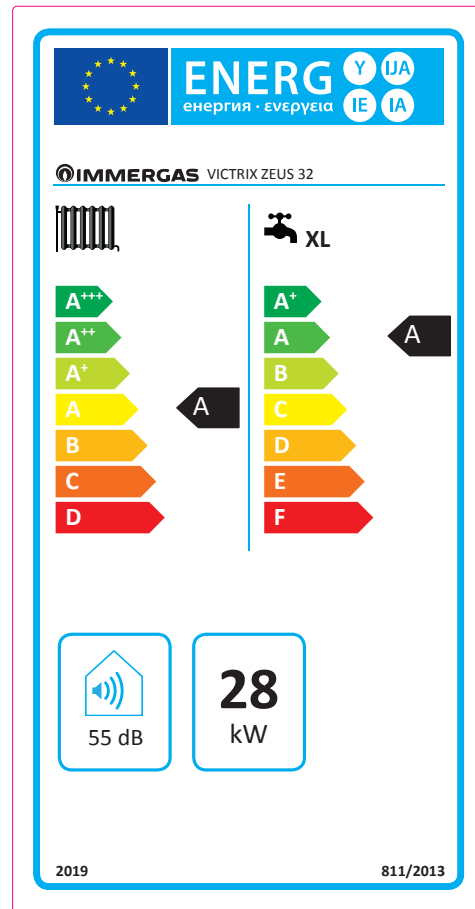

Parameter	value
Annual energy consumption for the central heating mode (Q_{HE})	37,0 GJ
Annual electricity consumption for the domestic hot water function (AEC)	46 kWh
Annual fuel consumption for the domestic hot water function (AFC)	19,0 GJ
Seasonal space heating energy efficiency (η_s)	92 %
Water heating energy efficiency (η_{wh})	81 %

Parameter	value
Annual energy consumption for the central heating mode (Q_{HE})	50,0 GJ
Annual electricity consumption for the domestic hot water function (AEC)	61 kWh
Annual fuel consumption for the domestic hot water function (AFC)	19,0 GJ
Seasonal space heating energy efficiency (η_s)	92 %
Water heating energy efficiency (η_{wh})	80 %

For proper installation of the device, refer to chapter 1 of this booklet (for the installer) and current installation regulations. For proper maintenance refer to chapter 3 of this booklet (for the maintenance technician) and adhere to the frequencies and methods set out herein.

4.7 PARAMETERS FOR FILLING IN THE PACKAGE FICHE.

In case you should wish to install an assembly, starting from the Victrix Zeus 25-32 boiler, use the assembly charts in (Fig. 56 and 59).

To complete it properly, fill the relevant spaces (as shown in the package fiche facsimile (Fig. 54 and 57) with the values shown in tables (Fig. 55 and 58).

The remaining values must be obtained from the technical data sheets of the products used to make up the assembly (e.g. solar devices, integration heat pumps, temperature controllers).

Use board (Fig. 56) for “assemblies” related to the central heating mode (e.g.: boiler + temperature controller).

Use board (Fig. 59) for “assemblies” related to the domestic hot water function (e.g.: boiler + solar thermal system).

Facsimile for filling in the package fiche for room central heating systems.

Seasonal central heating energy efficiency of the boiler	<div style="border: 1px solid black; padding: 2px; display: inline-block;">1</div> <div style="border: 1px solid black; padding: 2px; display: inline-block; width: 40px; text-align: center;">I</div> %																														
Temperature control From temperature control board	<div style="border: 1px solid black; padding: 2px; display: inline-block;">2</div> <div style="border: 1px solid black; padding: 2px; display: inline-block; width: 40px; text-align: center;">+</div> <div style="border: 1px solid black; padding: 2px; display: inline-block; width: 40px; text-align: center;"> </div> %																														
<div style="border: 1px solid black; padding: 5px; width: fit-content; margin: 0 auto;"> Class I = 1 %, Class II = 2 %, Class III = 1.5 %, Class IV = 2 %, Class V = 3 %, Class VI = 4 %, Class VII = 3.5 %, Class VIII = 5 % </div>																															
Supplementary boiler From boiler board	<div style="border: 1px solid black; padding: 2px; display: inline-block;">3</div> <div style="border: 1px solid black; padding: 2px; display: inline-block; width: 40px; text-align: center;">±</div> <div style="border: 1px solid black; padding: 2px; display: inline-block; width: 40px; text-align: center;"> </div> %																														
<div style="border: 1px solid black; padding: 2px; display: inline-block; width: 60%; margin: 0 auto;"> Seasonal central heating energy efficiency (in %) </div>																															
$(\text{ } - 'I') \times 0.1 = \pm \text{ }$																															
Solar contribution																															
From the board of the solar device																															
<div style="border: 1px solid black; padding: 2px; display: inline-block; width: 15%;">Dimensions of the manifold (in m²)</div>	<div style="border: 1px solid black; padding: 2px; display: inline-block; width: 15%;">Volume of the tank (in m³)</div>																														
<div style="border: 1px solid black; padding: 2px; display: inline-block; width: 15%;">Efficiency of the manifold (in %)</div>	<div style="border: 1px solid black; padding: 2px; display: inline-block; width: 15%;">Classification of the tank A* = 0.95, A = 0.91, B = 0.86, C = 0.83, D-G = 0.81</div>																														
<div style="border: 1px solid black; padding: 2px; display: inline-block;">4</div> <div style="border: 1px solid black; padding: 2px; display: inline-block; width: 40px; text-align: center;">+</div> <div style="border: 1px solid black; padding: 2px; display: inline-block; width: 40px; text-align: center;"> </div> %																															
$('III' \times \text{ } + 'IV' \times \text{ }) \times (0.9 \times (\text{ } / 100) \times \text{ } = + \text{ }$																															
Supplementary heat pump From the heat pump board	<div style="border: 1px solid black; padding: 2px; display: inline-block;">5</div> <div style="border: 1px solid black; padding: 2px; display: inline-block; width: 40px; text-align: center;">+</div> <div style="border: 1px solid black; padding: 2px; display: inline-block; width: 40px; text-align: center;"> </div> %																														
<div style="border: 1px solid black; padding: 2px; display: inline-block; width: 60%; margin: 0 auto;"> Seasonal central heating energy efficiency (in %) </div>																															
$(\text{ } - 'I') \times 'II' = + \text{ }$																															
Solar contribution and supplementary heat pump																															
Select the lowest value	<div style="border: 1px solid black; padding: 2px; display: inline-block;">6</div> <div style="border: 1px solid black; padding: 2px; display: inline-block; width: 40px; text-align: center;">-</div> <div style="border: 1px solid black; padding: 2px; display: inline-block; width: 40px; text-align: center;"> </div> %																														
$0.5 \times \text{ } \text{ O } 0.5 \times \text{ } = - \text{ }$																															
<div style="border: 1px solid black; padding: 2px; display: inline-block;">7</div> <div style="border: 1px solid black; padding: 2px; display: inline-block; width: 40px; text-align: center;"> </div> %																															
Seasonal central heating energy efficiency of the set																															
Seasonal central heating energy efficiency class of the set																															
<div style="border: 1px solid black; padding: 10px; width: fit-content; margin: 0 auto;"> <table style="width: 100%; text-align: center; border-collapse: collapse;"> <tr> <td style="width: 10%;"><input type="checkbox"/></td> <td style="width: 10%;"><input type="checkbox"/></td> <td style="width: 10%;"><input type="checkbox"/></td> <td style="width: 10%;"><input type="checkbox"/></td> <td style="width: 10%;"><input type="checkbox"/></td> <td style="width: 10%;"><input type="checkbox"/></td> <td style="width: 10%;"><input type="checkbox"/></td> <td style="width: 10%;"><input type="checkbox"/></td> <td style="width: 10%;"><input type="checkbox"/></td> <td style="width: 10%;"><input type="checkbox"/></td> </tr> <tr> <td style="font-weight: bold; font-size: 1.2em;">G</td> <td style="font-weight: bold; font-size: 1.2em;">F</td> <td style="font-weight: bold; font-size: 1.2em;">E</td> <td style="font-weight: bold; font-size: 1.2em;">D</td> <td style="font-weight: bold; font-size: 1.2em;">C</td> <td style="font-weight: bold; font-size: 1.2em;">B</td> <td style="font-weight: bold; font-size: 1.2em;">A</td> <td style="font-weight: bold; font-size: 1.2em;">A⁺</td> <td style="font-weight: bold; font-size: 1.2em;">A⁺⁺</td> <td style="font-weight: bold; font-size: 1.2em;">A⁺⁺⁺</td> </tr> <tr> <td>< 30 %</td> <td>≥ 30 %</td> <td>≥ 34 %</td> <td>≥ 36 %</td> <td>≥ 75 %</td> <td>≥ 82 %</td> <td>≥ 90 %</td> <td>≥ 98 %</td> <td>≥ 125 %</td> <td>≥ 150 %</td> </tr> </table> </div>		<input type="checkbox"/>	<input type="checkbox"/>	<input type="checkbox"/>	<input type="checkbox"/>	<input type="checkbox"/>	<input type="checkbox"/>	<input type="checkbox"/>	<input type="checkbox"/>	<input type="checkbox"/>	<input type="checkbox"/>	G	F	E	D	C	B	A	A ⁺	A ⁺⁺	A ⁺⁺⁺	< 30 %	≥ 30 %	≥ 34 %	≥ 36 %	≥ 75 %	≥ 82 %	≥ 90 %	≥ 98 %	≥ 125 %	≥ 150 %
<input type="checkbox"/>	<input type="checkbox"/>	<input type="checkbox"/>	<input type="checkbox"/>	<input type="checkbox"/>	<input type="checkbox"/>	<input type="checkbox"/>	<input type="checkbox"/>	<input type="checkbox"/>	<input type="checkbox"/>																						
G	F	E	D	C	B	A	A ⁺	A ⁺⁺	A ⁺⁺⁺																						
< 30 %	≥ 30 %	≥ 34 %	≥ 36 %	≥ 75 %	≥ 82 %	≥ 90 %	≥ 98 %	≥ 125 %	≥ 150 %																						
Boiler and supplementary heat pump installed with low temperature heat emitters at 35 °C?	<div style="border: 1px solid black; padding: 2px; display: inline-block;">7</div> <div style="border: 1px solid black; padding: 2px; display: inline-block; width: 40px; text-align: center;"> </div> + (50 x 'II') = <div style="border: 1px solid black; padding: 2px; display: inline-block; width: 40px; text-align: center;"> </div> %																														
From the board of the heat pump																															
<p>The energy efficiency of the set of products indicated in this sheet may not reflect the actual energy efficiency after installation since such efficiency is affected by additional factors, such as the heat loss in the distribution system and the size of the products compared to the size and features of the building.</p>																															

Parameters for filling in the assembly chart.

Parameter	Victrix Zeus 25	Victrix Zeus 32
'I'	92	92
'II'	*	*
'III'	1.33	0.95
'IV'	0.52	0.37

* to be established by means of table 5 of Regulation 811/2013 in case of "assembly" including a heat pump to integrate the boiler. In this case the boiler must be considered as the main appliance of the assembly.

Room central heating system package fiche.

Seasonal central heating energy efficiency of the boiler 1 %

Temperature control 2 %
 From temperature control board
Class I = 1 %, Class II = 2 %,
Class III = 1.5 %, Class IV = 2 %,
Class V = 3 %, Class VI = 4 %,
Class VII = 3.5 %, Class VIII = 5 % +

Supplementary boiler 3 %
 From boiler board
Seasonal central heating energy efficiency (in %)
 $(\text{ - \text{ }) \times 0.1 = \pm \text{ } %$

Solar contribution 4 %
 From the board of the solar device
Dimensions of the manifold (in m²) Volume of the tank (in m³) Efficiency of the manifold (in %)
 $(\text{ } \times \text{ } + \text{ } \times \text{ }) \times (0.9 \times (\text{ } / 100) \times \text{ } = + \text{ } %$
Classification of the tank
A* = 0.95, A = 0.91,
B = 0.86, C = 0.83,
D-G = 0.81

Supplementary heat pump 5 %
 From the heat pump board
Seasonal central heating energy efficiency (in %)
 $(\text{ - \text{ }) \times \text{ } = + \text{ } %$

Solar contribution and supplementary heat pump 6 %
 Select the lowest value $0.5 \times \text{ } \text{ O } 0.5 \times \text{ } = - \text{ } %$

Seasonal central heating energy efficiency of the set 7 %

Seasonal central heating energy efficiency class of the set

G

F

E

D

C

B

A

A⁺

A⁺⁺

A⁺⁺⁺

< 30 %
≥ 30 %
≥ 34 %
≥ 36 %
≥ 75 %
≥ 82 %
≥ 90 %
≥ 98 %
≥ 125 %
≥ 150 %

Boiler and supplementary heat pump installed with low temperature heat emitters at 35 °C? 7 %
 From the board of the heat pump $\text{ } + (50 \times \text{ }) = \text{ } %$

The energy efficiency of the set of products indicated in this sheet may not reflect the actual energy efficiency after installation since such efficiency is affected by additional factors, such as the heat loss in the distribution system and the size of the products compared to the size and features of the building.

Facsimile for filling in the domestic hot water production system package fiche.

Water heating energy efficiency of combination boiler ① %

Stated load profile:

Solar contribution

From the board of the solar device

Auxiliary electricity

$$(1.1 \times \text{'I'} - 10\%) \times \text{'II'} - \text{'III'} - \text{'I'} = + \text{②} \text{ \%}$$

Water heating energy efficiency of the assembly in average climate conditions ③ %

Water heating energy efficiency class of the assembly in average climate conditions

	<input type="checkbox"/>	<input type="checkbox"/>	<input type="checkbox"/>	<input type="checkbox"/>	<input type="checkbox"/>	<input type="checkbox"/>	<input type="checkbox"/>	<input type="checkbox"/>	<input type="checkbox"/>	<input type="checkbox"/>
	G	F	E	D	C	B	A	A⁺	A⁺⁺	A⁺⁺⁺
<input type="checkbox"/> M	< 27 %	≥ 27 %	≥ 30 %	≥ 33 %	≥ 36 %	≥ 39 %	≥ 65 %	≥ 100 %	≥ 130 %	≥ 163 %
<input type="checkbox"/> L	< 27 %	≥ 27 %	≥ 30 %	≥ 34 %	≥ 37 %	≥ 50 %	≥ 75 %	≥ 115 %	≥ 150 %	≥ 188 %
<input type="checkbox"/> XL	< 27 %	≥ 27 %	≥ 30 %	≥ 35 %	≥ 38 %	≥ 55 %	≥ 80 %	≥ 123 %	≥ 160 %	≥ 200 %
<input type="checkbox"/> XXL	< 28 %	≥ 28 %	≥ 32 %	≥ 36 %	≥ 40 %	≥ 60 %	≥ 85 %	≥ 131 %	≥ 170 %	≥ 213 %

Water heating energy efficiency class in colder and hotter climate conditions

Colder: ③ - 0.2 x ② = %

Hotter: ③ + 0.4 x ② = %

The energy efficiency of the set of products indicated in this sheet may not reflect the actual energy efficiency after installation since such efficiency is affected by additional factors, such as the heat loss in the distribution system and the size of the products compared to the size and features of the building.

Parameters for filling in the DHW package fiche.

Parameter	Victrix Zeus 25	Victrix Zeus 32
‘I’	81	80
‘II’	*	*
‘III’	*	*

* to be determined according to Regulation 811/2013 and transient calculation methods as per Notice of the European Community no. 207/2014.

58

Domestic hot water production system package fiche.

Water heating energy efficiency of combination boiler

%

Stated load profile:

Solar contribution

From the board of the solar device

Auxiliary electricity

$(1.1 \times \text{---} - 10\%) \times \text{---} - \text{---} = + \text{---} \%$

Water heating energy efficiency of the assembly in average climate conditions

%

Water heating energy efficiency class of the assembly in average climate conditions

	G	F	E	D	C	B	A	A ⁺	A ⁺⁺	A ⁺⁺⁺
<input type="checkbox"/> M	< 27 %	≥ 27 %	≥ 30 %	≥ 33 %	≥ 36 %	≥ 39 %	≥ 65 %	≥ 100 %	≥ 130 %	≥ 163 %
<input type="checkbox"/> L	< 27 %	≥ 27 %	≥ 30 %	≥ 34 %	≥ 37 %	≥ 50 %	≥ 75 %	≥ 115 %	≥ 150 %	≥ 188 %
<input type="checkbox"/> XL	< 27 %	≥ 27 %	≥ 30 %	≥ 35 %	≥ 38 %	≥ 55 %	≥ 80 %	≥ 123 %	≥ 160 %	≥ 200 %
<input type="checkbox"/> XXL	< 28 %	≥ 28 %	≥ 32 %	≥ 36 %	≥ 40 %	≥ 60 %	≥ 85 %	≥ 131 %	≥ 170 %	≥ 213 %

Water heating energy efficiency class in colder and hotter climate conditions

Colder: $\text{---} - 0.2 \times \text{---} = \text{---} \%$

Hotter: $\text{---} + 0.4 \times \text{---} = \text{---} \%$

The energy efficiency of the set of products indicated in this sheet may not reflect the actual energy efficiency after installation since such efficiency is affected by additional factors, such as the heat loss in the distribution system and the size of the products compared to the size and features of the building.

59



This instruction booklet
is made of ecological paper



immergas.com

Immergas S.p.A.
42041 Brescello (RE) - Italy
Tel. 0522.689011
Fax 0522.680617



IMMERGAS
IMMERGAS SPA - ITALY
CERTIFIED COMPANY
UNI EN ISO 9001:2015

Design, manufacture and post-sale assistance of gas
boilers, gas water heaters and related accessories

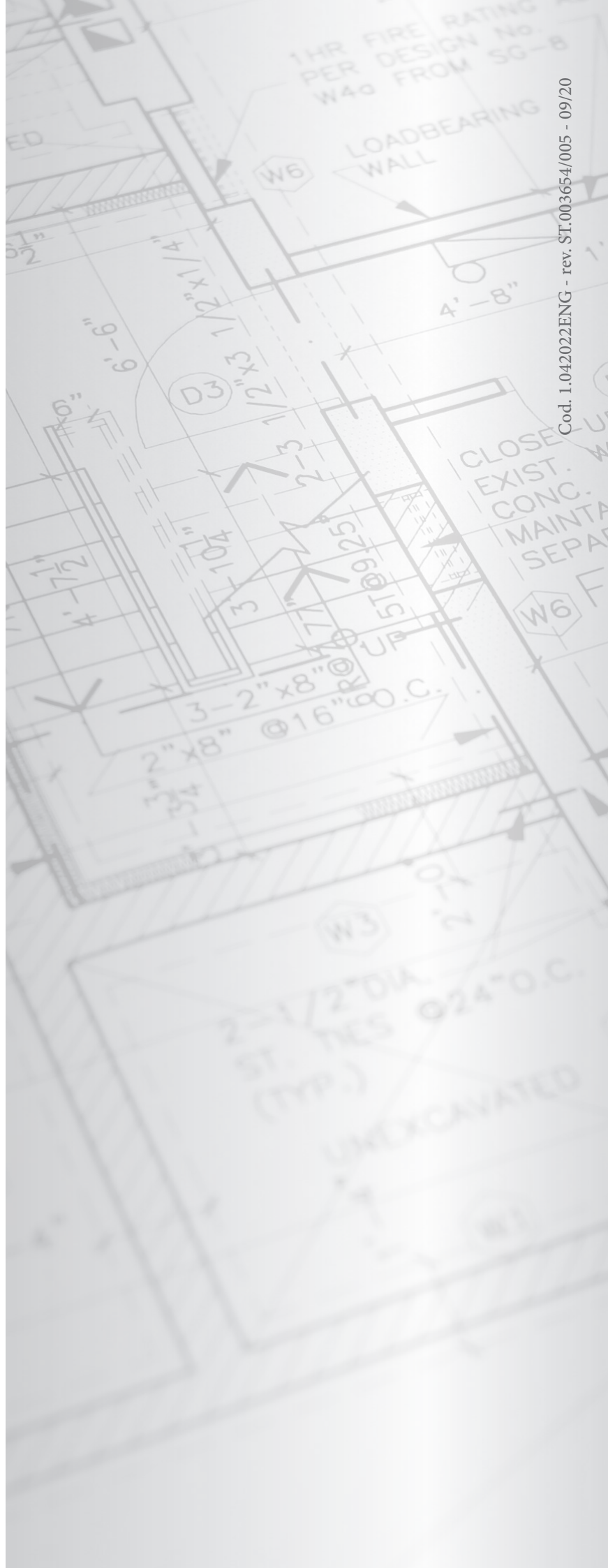

Cod. I.042022ENG - rev. ST.003654/005 - 09/20