

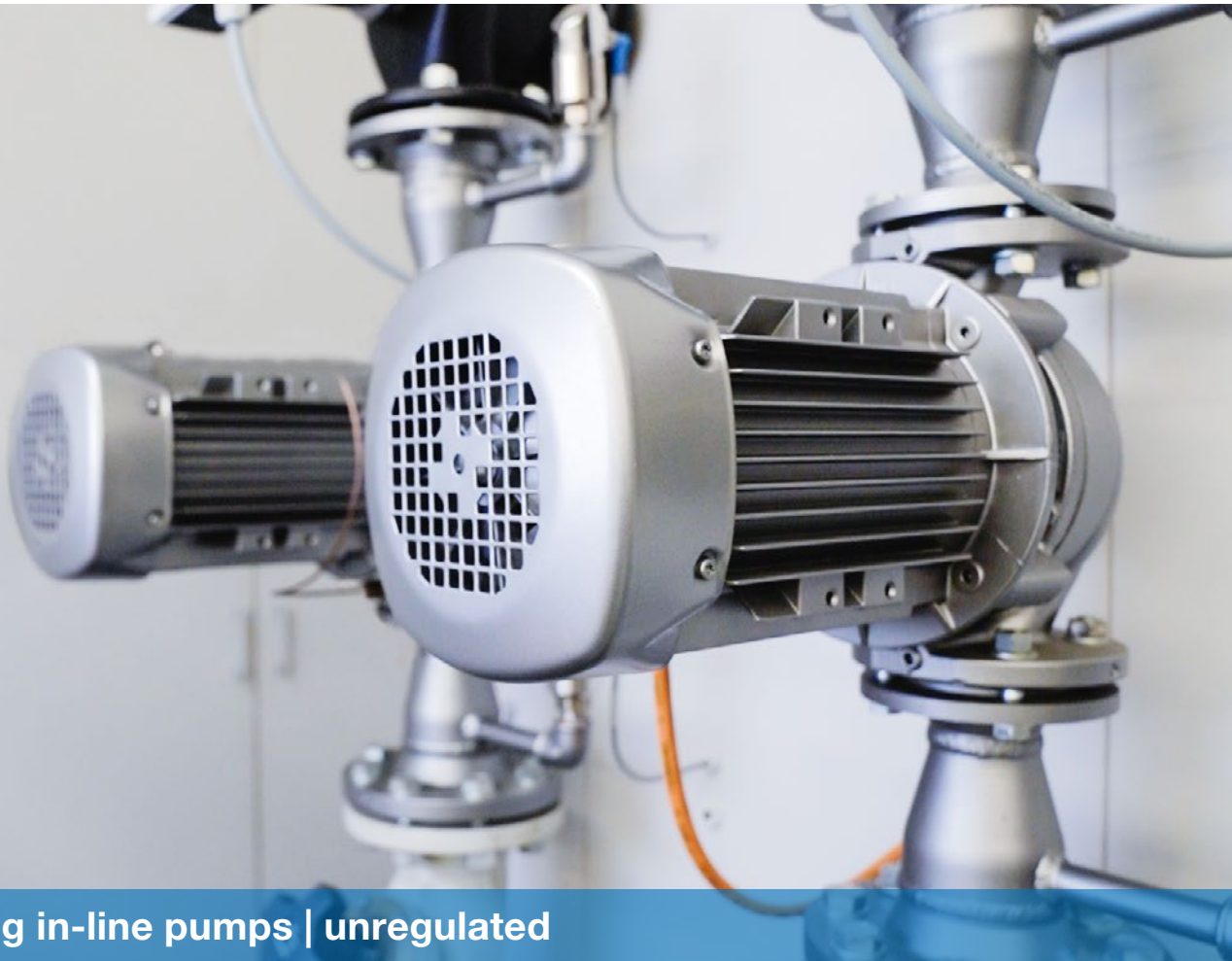

VariA

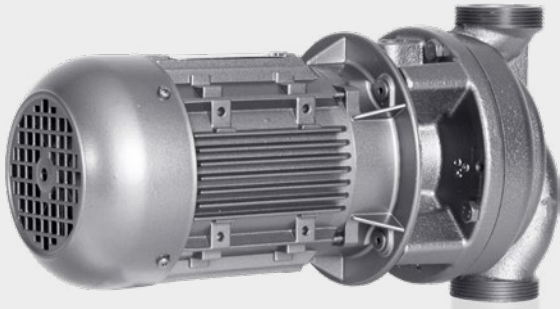

Dry-running in-line pumps | unregulated

Moving people and elements



A matter of the heart – Biral impresses customers with its comprehensiveness and expertise.

For over 100 years, we have dedicated ourselves to one task – to make the best pumps and systems out there. They may only serve the purpose of moving fluids from A to B. But they do so reliably, sustainable and flawlessly, making users' lives easier. If there is ever an emergency, you can depend on our reliable support and service, further consolidating your trust in Biral.



“Our intelligent solutions save energy and resources.”
Sjef de Bruijn, CEO

Biral's values – at our core.



Customer-focused

We see ourselves as Partners.

Purchasing our products creates an alliance. We offer our customers comprehensive assistance, from the moment they contact us through to purchase, support and the renewal of existing systems.

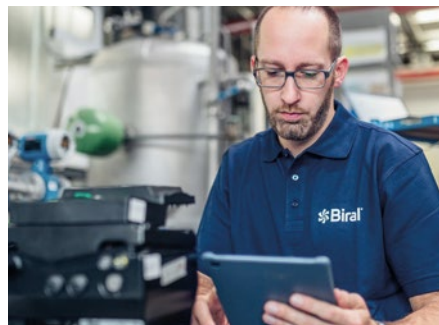

Intelligent

We are smart.

Our solutions impress customers thanks to their ingenuity, simplicity and the fact that they are tailored to meet their needs.



Human

We are personable.

Providing personal consultations is very important to us and lays the foundation for understanding our customers all across the world. This approach forms the basis of all our new solutions and developments.

Contents

General details	4
1 Introduction	4
1.1 Biral ECO Design	4
1.2 Efficiency requirements	4
1.3 Versions of the VariA	4
1.4 Product series	5
1.5 Safety calculation for cavitation protection/ minimum intake flow	7
2 Design	8
2.1 Connections	9
2.2 Installation options	9
2.3 Materials	9
3 Electrical data	10
3.1 Electrical connection of unregulated VariA	10
3.2 VariA motor protection	10
4 Order reference	11
5 Combined graphs	11
6 Data sheets	12
6.1 NPSH	30

General details

1 Introduction

The VariA

With the VariA, Biral is bringing a new reworked and extended range of inline pumps onto the market.

1.1 Biral ECO Design

The ECO design label from Biral shows you at a glance that your pump is in the top category when it comes to energy efficiency. The label draws the attention straight to the efficiency index for the pump and motor.

VariA pumps from Biral are energy-optimised and correspond to the efficiency requirements of the regulation (EU) no. 547/2012 of the Commission, which came into force from 1 January 2013.

Since then, all pumps have been marked/described with a new energy efficiency index (MEI).

The «minimum efficiency index» (MEI) is a dimensionless size for the hydraulic pump efficiency level at the best operating point, as well as for partial load and overload.

1.2 Efficiency requirements

From 1 January 2015 $MEI \geq 0.4$

Reference value $MEI \geq 0.70$

The efficiency level of a pump with a corrected impeller is usually lower than that of a pump with full impeller diameter. By correcting the impeller, the pump is adapted to a specific operating point, whereby the energy consumption is decreased. The minimum efficiency index (MEI) refers to the full impeller diameter. The operation of a water pump at different operating points may be more efficient and economical if, for example, it is controlled via a variable speed control that adjusts the pump operation to the system.

For further information with regard to the new regulations, please visit www.biral.ch.

1.3 Versions of the VariA

RED

Temperature limits: +15 °C ... +140 °C

Glycol proportion limit in medium: $\leq 25\%$

GREEN 2

Temperature limits: -20 °C ... +90 °C

Glycol proportion limit in medium: $\leq 50\%$

This version has an additional protective coating.

The mechanical seal is suitable for glycol contents up to 50%.

Floating ring seals that are operated close to their permitted maximum temperature must be regularly serviced and replaced if necessary, as they are subject to increased wear under such conditions.

1.4 Product series

DN	Casing length	Description	Earlier description	Voltage 3x400V	Flange PN 6	PN 16
32	190	VariA 32-2 190 4 0.25	EBZ 35V/4-85	•		•
		VariA 32-2.8 190 4 0.25	EBZ 35V/4-95	•		•
		VariA 32-3.5 190 4 0.25	EBZ 35V/4-105	•		•
	190	VariA 32-8 190 2 0.55	EBZ 35V/2-85	•		•
		VariA 32-11 190 2 0.75	EBZ 35V/2-95	•		•
		VariA 32-14 190 2 1.1	EBZ 35V/2-105	•		•
40	250	VariA 40-2.5 250 4 0.25	EBZ 45V/4-92	•		•
		VariA 40-3.5 250 4 0.25	EBZ 45V/4-108	•		•
		VariA 40-4.5 250 4 0.25	EBZ 45V/4-120	•		•
	440	VariA 40-15 440 4 1.5	EBZ 40V/4-215	•		•
		VariA 40-20 440 4 2.2	EBZ 40V/4-241	•		•
		VariA 40-23 440 4 3	EBZ 40V/4-254	•		•
	250	VariA 40-9 250 2 0.75	EBZ 45V/2-92	•		•
		VariA 40-14 250 2 1.1	EBZ 45V/2-108	•		•
		VariA 40-17 250 2 1.5	EBZ 45V/2-120	•		•
	340	VariA 40-18 340 2 2.2		•		•
		VariA 40-23 340 2 3		•		•
		VariA 40-30 340 2 4		•		•
		VariA 40-38 340 2 5.5		•		•
	50	270	VariA 50-4.5 270 4 0.25	EBZ 55V/4-118	•	
VariA 50-5.5 270 4 0.37			EBZ 55V/4-132	•		•
VariA 50-7 270 4 0.55			EBZ 55V/4-145	•		•
50	440	VariA 50-16 440 4 2.2	EBZ 50V/4-222	•		•
		VariA 50-20 440 4 3	EBZ 50V/4-243	•		•
		VariA 50-23 440 4 4	EBZ 50V/4-254	•		•
	270	VariA 50-15 270 2 1.5	EBZ 55V/2-110	•		•
		VariA 50-18 270 2 2.2	EBZ 55V/2-118	•		•
		VariA 50-22 270 2 3	EBZ 55V/2-132	•		•
		VariA 50-28 270 2 4	EBZ 55V/2-145	•		•
					•	
65	340	VariA 65-5.5 340 4 0.55	EBZ 65V/4-130	•		•
		VariA 65-7 340 4 0.75	EBZ 65V/4-143	•		•
		VariA 65-8.5 340 4 1.1	EBZ 65V/4-158	•		•
		VariA 65-10 340 4 1.5	EBZ 65V/4-170	•		•
	475	VariA 65-12 475 4 2.2	EBZ 67V/4-193	•		•
		VariA 65-15 475 4 3	EBZ 67V/4-216	•		•
		VariA 65-17 475 4 4	EBZ 67V/4-234	•		•
		VariA 65-22 475 4 5.5	EBZ 67V/4-260	•		•
					•	
	340	VariA 65-21 340 2 4	EBZ 65V/2-130	•		•
		VariA 65-27 340 2 5.5	EBZ 65V/2-143	•		•
		VariA 65-34 340 2 7.5	EBZ 65V/2-158	•		•
					•	
80	400	VariA 80-7 400 4 1.1	EBZ 85V/4-148	•	•	•
		VariA 80-8.5 400 4 1.5	EBZ 85V/4-162	•	•	•
		VariA 80-10 400 4 2.2	EBZ 85V/4-176	•	•	•
		VariA 80-14 400 4 3	EBZ 85V/4-200	•	•	•

DN	Casing length	Description	Earlier description	Voltage 3x400V	Flange PN 6	PN 16
	500	VariA 80-13 500 4 3	EBZ 87V/4-210	•		•
		VariA 80-16 500 4 4	EBZ 87V/4-225	•		•
		VariA 80-19 500 4 5.5	EBZ 87V/4-245	•		•
		VariA 80-23 500 4 7.5	EBZ 87V/4-269	•		•
100	450	VariA 100-8 450 4 2.2	EBZ 100V/4-158	•	•	•
		VariA 100-10 450 4 3	EBZ 100V/4-171	•	•	•
		VariA 100-11.5 450 4 4	EBZ 100V/4-186	•	•	•
		VariA 100-14 450 4 5.5	EBZ 100V/4-200	•	•	•
	670	VariA 100-16 670 4 5.5		•		•
		VariA 100-19 670 4 7.5		•		•
		VariA 100-25 670 4 11		•		•
125	620	VariA 125-12.5 620 4 4	EBZ 126V/4-196	•		•
		VariA 125-15 620 4 5.5	EBZ 126V/4-218	•		•
		VariA 125-18 620 4 7.5	EBZ 126V/4-242	•		•
		VariA 125-23 620 4 11	EBZ 126V/4-269	•		•
150	750	VariA 150-11.5 750 4 5.5	EBZ 150V/4-198	•		•
		VariA 150-13.5 750 4 7.5	EBZ 150V/4-210	•		•
		VariA 150-17 750 4 11	EBZ 150V/4-238	•		•
		VariA 150-22 750 4 18.5	EBZ 150V/4-269	•		•

1.5 Safety calculation for cavitation protection/minimum intake flow

$$H = p_b \times 10.2 - NPSH - H_f - H_v - H_s$$

H = Intake flow required

p_b = Barometer status in bar.

(The barometer status may be 1 bar).

In closed equipment p_b gives the system pressure in bar

NPSH = **Net Positive Suction Head** in mWC

(to be read in the NPSH curve for the greatest flow rate that the pump will convey)

H_f = Friction loss in the suction line in mWC

H_v = Steam pressure level in mechanical seal in mWC

(see Steam pressure table)

t_m = Medium temperature

H_s = Security supplement

= 0.5 mWC

If the result of H is positive, there is sufficient system pressure in the pump and the pump runs safely.

If H is negative, there is too little system pressure and more system pressure must be increased at least by the amount of H.

Steam pressure table

$$t_{GLRD} = t_m + 15 \text{ } ^\circ\text{C}$$

t_m = Medium temperature

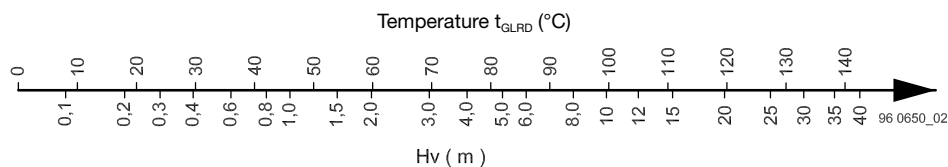

Example

45 m³/h, 6.5 m

Medium temperature $t_m = 60 \text{ } ^\circ\text{C}$

VariA 65-10 340 4 1.5

NPSH: m from pump diagram

p_b = 1 bar

H_f = 0 (acceptance)

H_v = 3.9 (75 °C)

H = $P_b \times 10.2 - NPSH - H_f - H_v - H_s$

«H» = $+10.2 - 4 - 0 - 3.9 - 0.5$

«H» = +1.8

H positive: Pump runs safely

H negative: Pump requires more system pressure at least at the minimum amount of H.

2 Design

Single-stage spiral casing pumps with closed radial impeller. Designs for horizontal or vertical installation. Suction and pressure port with the same flange dimensions are arranged in a line. Motor with extended shaft flange mounted to the pump casing. Shaft seal with mechanical seal. Pumps may only feed against closed valves in the short term.

Minimum volume flow: 10% of the maximum volume flow

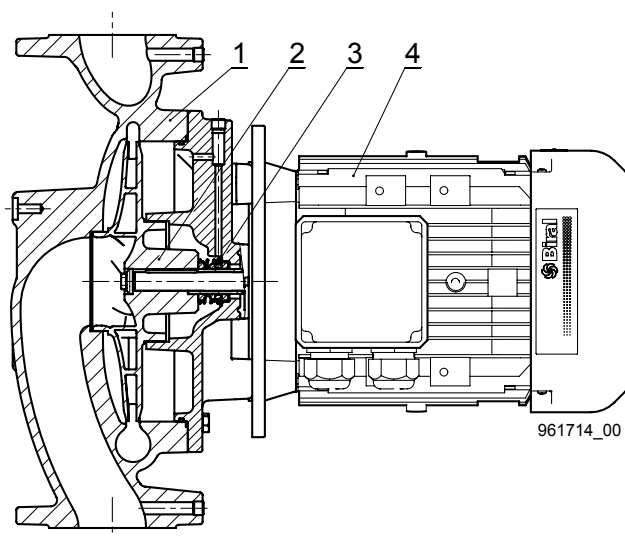

General details

Pos.	Component
1	Pump casing
2	Impeller
3	Mechanical seal (GLRD)
4	Motor

Drive

Surface-cooled three-phase short circuit motor with extended motor shaft

Model:	B5 /B14
Efficiency class: IE3 three-phase motors	≥ 0.75 kW
Protection type:	IP 55
Insulation class:	F
Voltage/frequency:	3×400V/50 Hz
Motor protection:	CTP 150 °C
Speed:	1450 1/min 2900 1/min
Ambient temperature:	up to 40 °C

Bearings

Built into motor, permanently greased, maintenance-free rolling bearing.

Shaft seal (mechanical seal)

Standard versions RED and GREEN 2 up to 50% glykol

Mech. seal Q7/Q7	Silicon carbide - Silicon carbide
Temperature ¹ t:	-20 °C to +140 °C
Pump pressure p:	10 bar

Special versions

Abrasive micro-parts in medium:

Mech. seal V-2 MG1	Silicon carbide - Silicon carbide
Temperature ¹ t:	0 °C to +90 °C
Pump pressure p:	10 bar

Increased pressure 16 bar/13 bar:

Mech. seal K-1 HJ92N released	Hard carbon - Silicon carbide
Temperature ¹ t:	0 °C to +120 °C
Pump pressure p:	16 bar
or	
Temperature ¹ t:	0 °C to +140 °C
Pump pressure p:	13 bar

¹ The permissible temperatures apply for water. For other fluids conveyed the temperature limits may change.

Other versions upon request.

The mechanical seal is a wearing part. Depending on the operating conditions and medium, there may be a certain amount of leakage. For special media or additives for frost/rust protection the choice of mechanical seal must be verified.

Mechanical seals according to DIN 24960.

Permissible intake pressure

Intake pressure plus delivery head (for amount 0) must not exceed the operating pressure (**pump pressure**). This depends on the mechanical seal used.

2.1 Connections

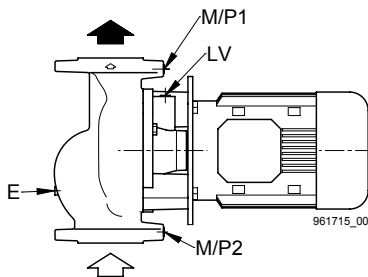

Fig. 1: Connections

E	* Emptying ¹	G1/4"
LV	Ventilation	G1/4"
M	Manometer connection ¹	2x G1/4"
P1	Pressure-side connection	G1/4"
P2	Suction-side connection	G1/4"
◇	Suction port	
◆	Pressure port	
	¹ if available	
	* VariA 80x500/100x670/125x620/150x750	

2.2 Installation options

Ventilator LV, Irrespective of the installation direction, always on the vertical axis, **top**.

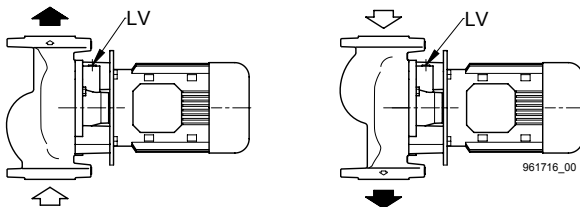

Fig. 2: «Flow direction» vertical installation.

Ventilation LV, Irrespective of the installation direction, always on the vertical axis, **top** Exception: H1

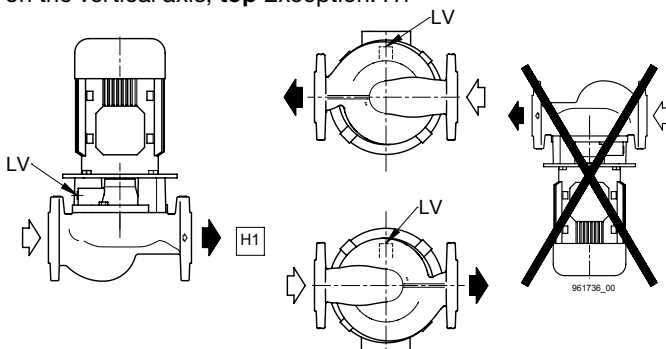

Fig. 3: «Flow direction» horizontal installation

Where there is insufficient carrying capacity for the pipes, pumps from nominal diameter DN 65 (475) mm can be fixed to a wall console with a support.

2.3 Materials

Pump type	Pump casing	Casing lid	Impeller
32-x 190	EN-GJL-250	EN-GJL-250	EN-GJL-150
40-x 250	EN-GJL-250	EN-GJL-250	EN-GJL-150
40-x 340	EN-GJL-250	EN-GJL-250	EN-GJL-200
40-x 440	EN-GJS-400-15	EN-GJS-400-15	EN-GJL-200
50-x 270	EN-GJL-250	EN-GJL-250	EN-GJL-200
50-x 440	EN-GJL-250	EN-GJS-400-15	EN-GJL-200
65-x 340	EN-GJL-250	EN-GJL-250	EN-GJL-200
65-x 475	EN-GJL-250	EN-GJS-400-15	EN-GJL-200
80-x 400	EN-GJL-250	EN-GJL-250	EN-GJL-200
80-x 500	EN-GJS-400-15	EN-GJS-400-15	EN-GJL-200
100-x 450	EN-GJL-250	EN-GJL-250	EN-GJL-200
100-x 670	EN-GJS-400-15	EN-GJS-400-15	EN-GJL-200
125-x 620	EN-GJS-400-15	EN-GJS-400-15	EN-GJL-200
150-x 750	EN-GJS-400-15	EN-GJS-400-15	EN-GJL-200

Pump type	Shaft	Shaft sleeve
32-x 190	X17CrNi16-2	G-CuSn5
40-x 250	X17CrNi16-2	G-CuSn5
40-x 340	X17CrNi16-2	G-CuSn5
40-x 440	X17CrNi16-2	G-CuSn5
50-x 270	X17CrNi16-2	G-CuSn5
50-x 440	X17CrNi16-2	G-CuSn5
65-x 340	X17CrNi16-2	G-CuSn5
65-x 475	X17CrNi16-2	G-CuSn5
80-x 400	X17CrNi16-2	G-CuSn5
80-x 500	X17CrNi16-2	G-CuSn5
100-x 450	X17CrNi16-2	G-CuSn5
100-x 670	X17CrNi16-2	G-CuSn5
125-x 620	X17CrNi16-2	G-CuSn5
150-x 750	X17CrNi16-2	G-CuSn5

When using the pump, please take account of relevant laws and regulations (e.g. DIN 4747 or DIN 4752, para. 4.5).

3 Electrical data

3.1 Electrical connection of unregulated VariA

Warning: the motor can only be switched according to the switching type for direct start-up given on the motor plate.

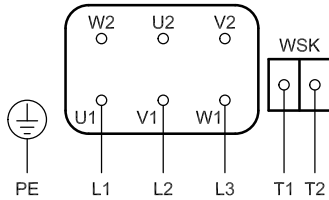

Fig. 4: Connection diagram for direct start-up

Warning: the motor must be suitable for Y/ Δ -start-up. See motor plate.

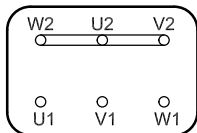

Fig. 5: Y-circuit

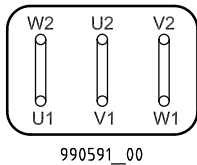

Fig. 6: Δ -circuit

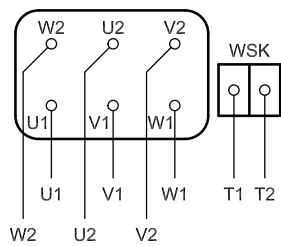

Fig. 7: Connection diagram for Y/ Δ

3.2 VariA motor protection

The motors are fitted as standard with coil protection contacts (CTP 150 °C). They must be supplied with an appropriate motor protection switch. Earthing according to local regulations.

4 Order reference

	VariA	80	-	13	-	500	4	3	RED
Series									
Nominal diameter DN [mm]									
Maximum pressure (for volume flow 0 m ³ /h)									
Overall length [mm]									
No. poles in motor 2 = 2900 1/min 4 = 1450 1/min									
Power P ₂ [kW]									
Field of application RED GREEN 2									

5 Combined graphs

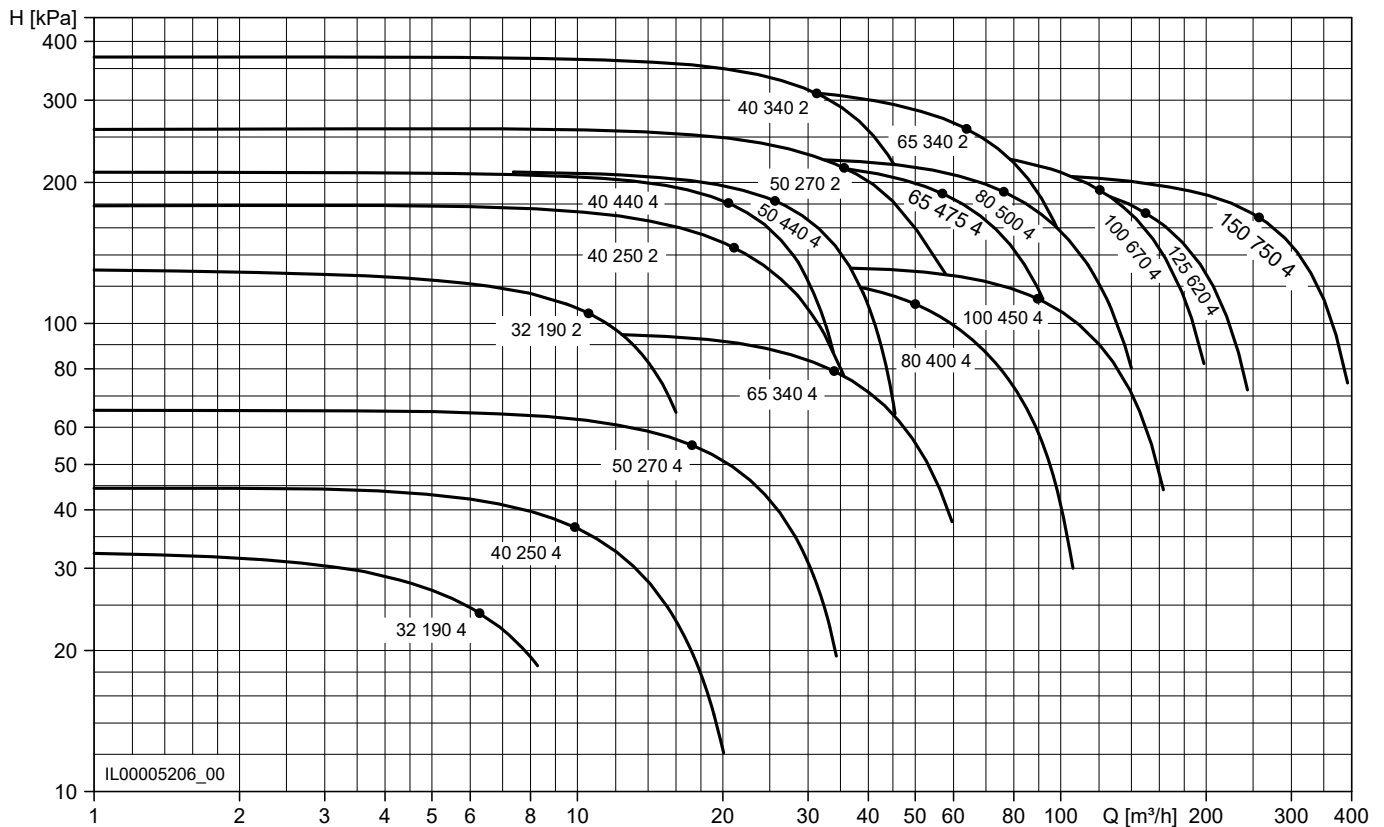

VariA 32-2 190 4 0.25
VariA 32-2.8 190 4 0.25
VariA 32-3.5 190 4 0.25

Nominal diameter	DN 32
Overall length	190 mm
Threaded connection	G2"
Max. operating pressure	10 bar
Ambient temperature	0°C ... +40°C
Medium temperatures RED	+15°C ... +140°C
Medium temperatures GREEN 2	-20°C ... +90°C
Glycol proportion RED	≤25%
Glycol proportion GREEN 2	≤50%

Electrical data
VariA 32-2 190 4 0.25

Absorbed power P_2	0.25 kW
Nominal current	0.81 A

VariA 32-2.8 190 4 0.25

Absorbed power P_2	0.25 kW
Nominal current	0.81 A

VariA 32-3.5 190 4 0.25

Absorbed power P_2	0.25 kW
Nominal current	0.81 A
Efficiency class	IE3
Protection type	IP55
Insulation class	F
Voltage / frequency	3x400V / 50 Hz
Motor protection	CTP 150°C
Speed	1450 1/min

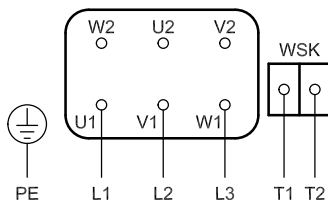
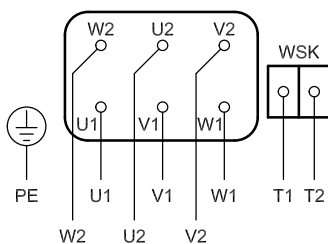
Connection diagram
Direct start-up

Y/Δ-start-up

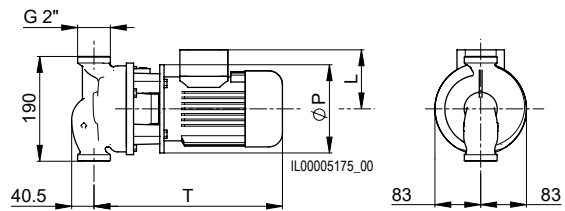
VariA... RED PN 16 without support
Art. No.

VariA 32-2 190 4 0.25	2210000150
VariA 32-2.8 190 4 0.25	2210010150
VariA 32-3.5 190 4 0.25	2210020150

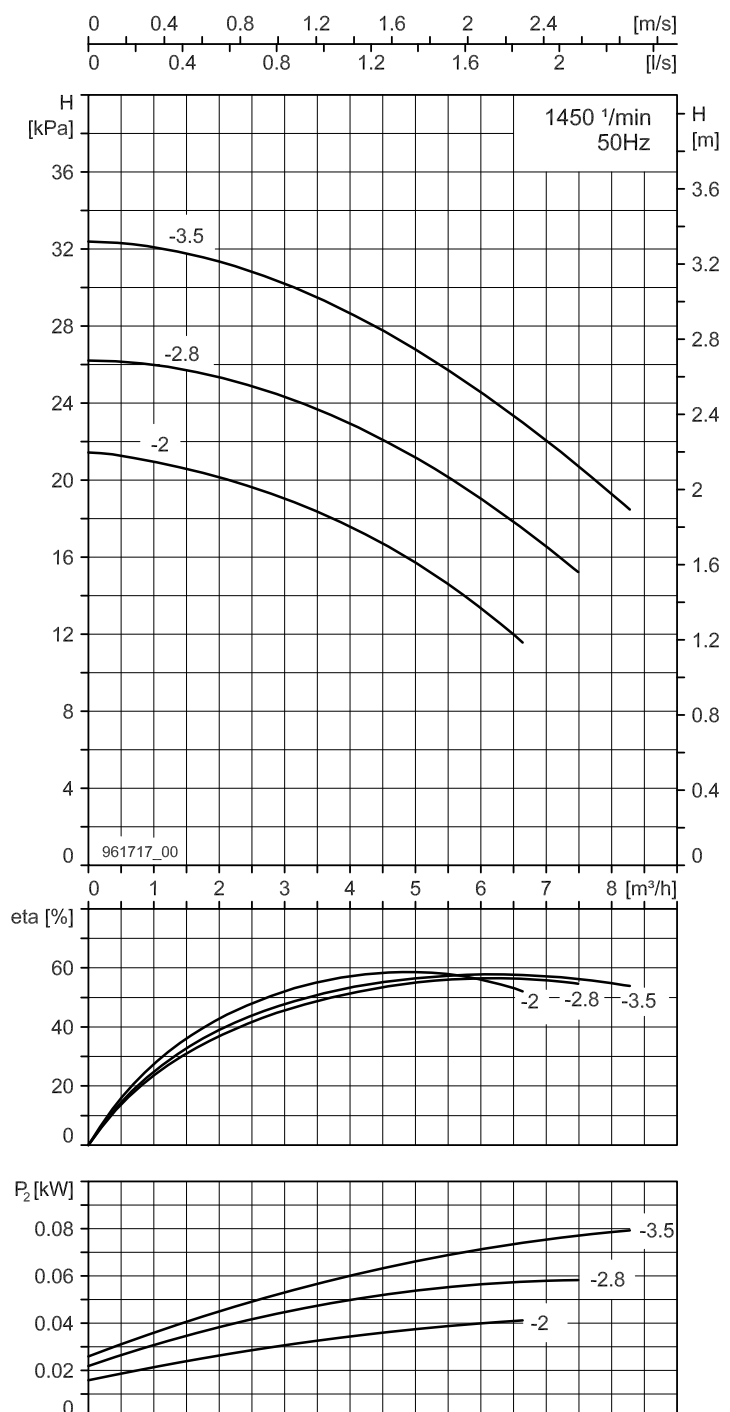

Type	T	P	L	Weight	Motor
VariA 32-2 190 4 0.25	342	160	107	15.5 kg	71M
VariA 32-2.8 190 4 0.25	342	160	107	15.5 kg	71M
VariA 32-3.5 190 4 0.25	342	160	107	15.5 kg	71M



VariA 32-8 190 2 0.55
VariA 32-11 190 2 0.75
VariA 32-14 190 2 1.1

Nominal diameter	DN 32
Overall length	190 mm
Threaded connection	G2"
Max. operating pressure	10 bar
Ambient temperature	0°C ... +40°C
Medium temperatures RED	+15°C ... +140°C
Medium temperatures GREEN 2	-20°C ... +90°C
Glycol proportion RED	≤25%
Glycol proportion GREEN 2	≤50%

Electrical data
VariA 32-8 190 2 0.55

Absorbed power P_2	0.55 kW
Nominale stroom	1.42 A

VariA 32-11 190 2 0.75

Absorbed power P_2	0.75 kW
Nominale stroom	1.70 A

VariA 32-14 190 2 1.1

Absorbed power P_2	1.10 kW
Nominale stroom	2.20 A
Efficiency class	IE3
Protection type	IP55
Insulation class	F
Voltage / frequency	3x400V / 50 Hz
Motor protection	CTP 150°C
Speed	2900 1/min

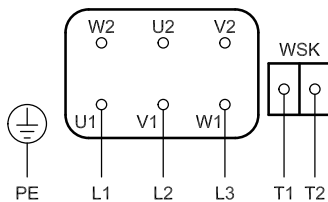
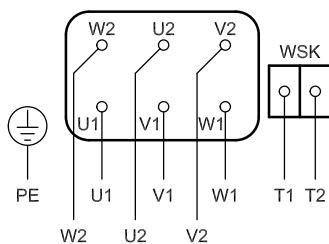
Connction diagram
Direct start-up

Y/Δ-start-up

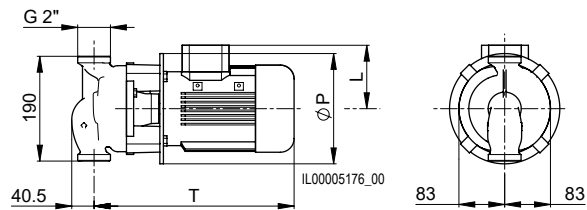
VariA... RED PN 16 without support
Art. No.

VariA 32-8 190 2 0.55	2210030150
VariA 32-11 190 2 0.75	2210040150
VariA 32-14 190 2 1.1	2210050150

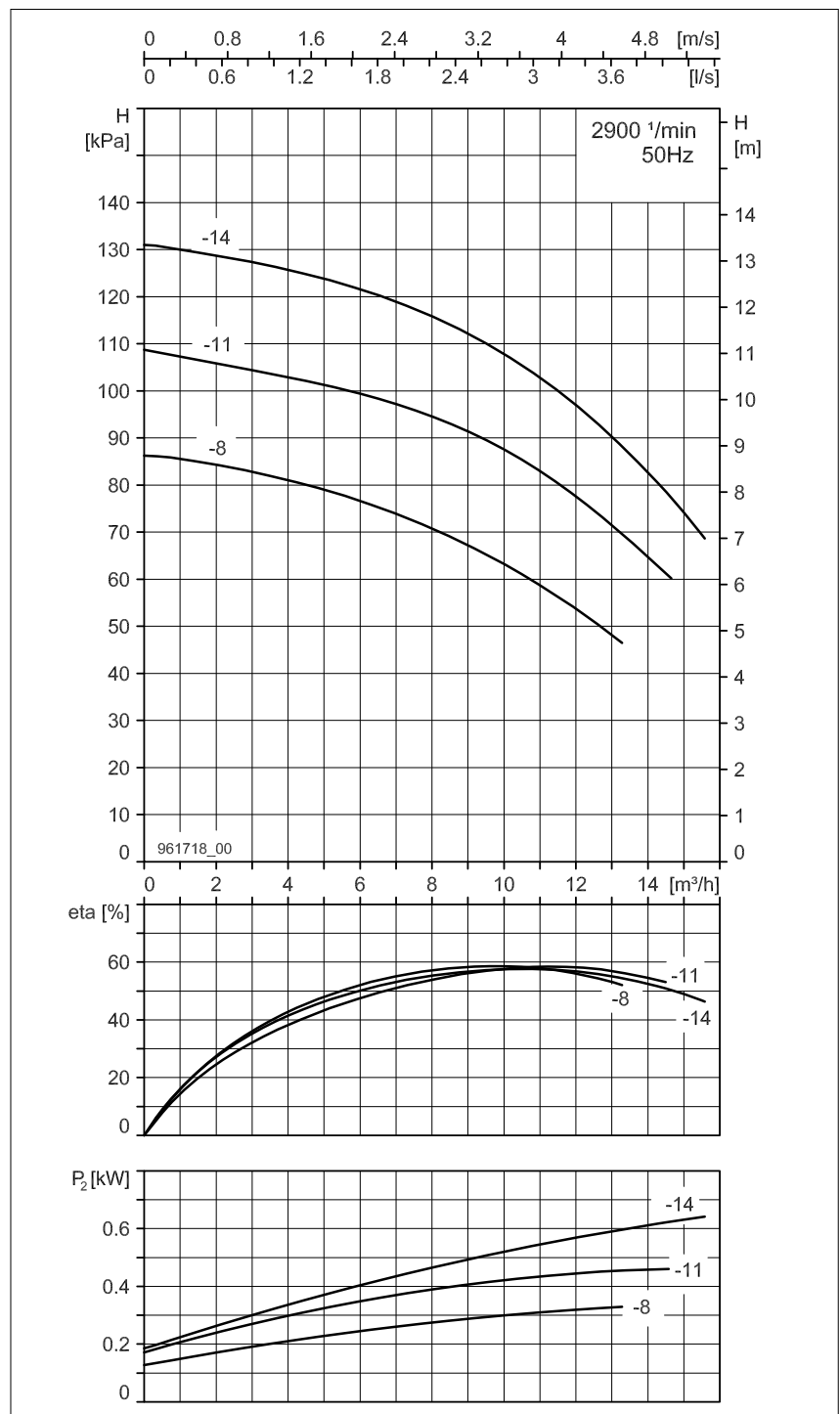

Type	T	P	L	Weight	Motor
VariA 32-8 190 2 0.55	342	160	107	16.5 kg	71M
VariA 32-11 190 2 0.75	363	200	115	19.0 kg	80M
VariA 32-14 190 2 1.1	363	200	115	20.0 kg	80M



VariA 40-2.5 250 4 0.25
VariA 40-3.5 250 4 0.25
VariA 40-4.5 250 4 0.25

Nominal diameter	DN 40
Overall length	250 mm
Flanged connection	PN 16
Max. operating pressure	10 bar
Ambient temperature	0°C ... +40°C
Medium temperatures RED	+15°C ... +140°C
Medium temperatures GREEN 2	-20°C ... +90°C
Glycol proportion RED	≤25%
Glycol proportion GREEN 2	≤50%

Electrical data
VariA 40-2.5 250 4 0.25

Absorbed power P_2	0.25 kW
Nominale stroom	0.81 A

VariA 40-3.5 250 4 0.25

Absorbed power P_2	0.25 kW
Nominale stroom	0.81 A

VariA 40-4.5 250 4 0.25

Absorbed power P_2	0.25 kW
Nominale stroom	0.81 A
Efficiency class	IE3
Protection type	IP55
Insulation class	F
Voltage / frequency	3x400V / 50 Hz
Motor protection	CTP 150°C
Speed	1450 1/min

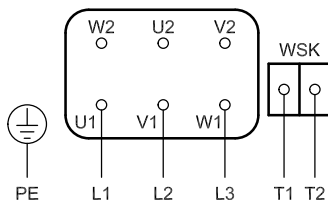
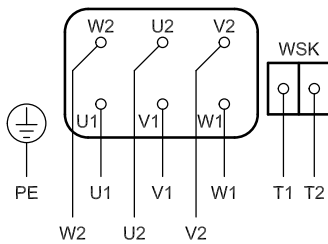
Connction diagram
Direct start-up

Y/Δ-start-up

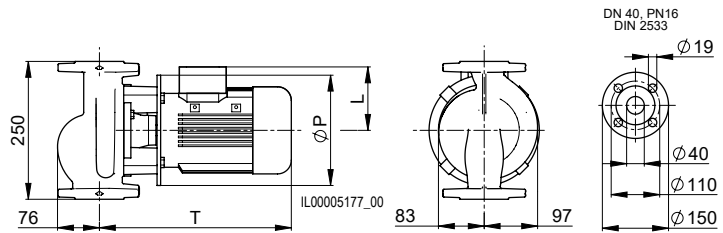
VariA... RED PN 16 without support
Art. No.

VariA 40-2.5 250 4 0.25	2210060150
VariA 40-3.5 250 4 0.25	2210070150
VariA 40-4.5 250 4 0.25	2210080150

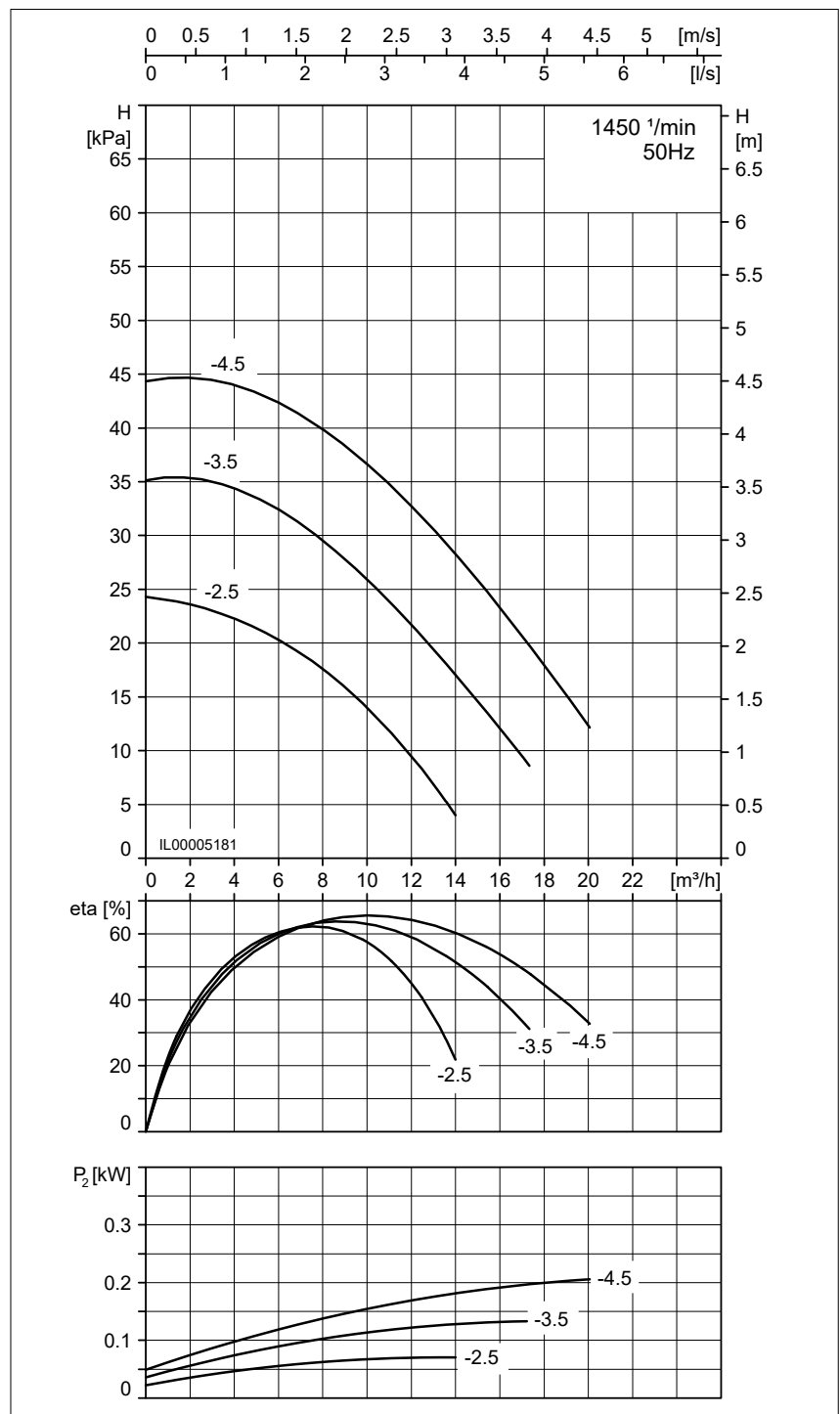

Type	T	P	L	Weight	Motor
VariA 40-2.5 250 4 0.25	327	160	107	19.0 kg	71M
VariA 40-3.5 250 4 0.25	327	160	107	19.0 kg	71M
VariA 40-4.5 250 4 0.25	327	160	107	19.0 kg	71M



VariA 40-15 440 4 1.5

VariA 40-20 440 4 2.2

VariA 40-23 440 4 3

Nominal diameter	DN 40
Overall length	440 mm
Flanged connection	PN 16
Max. operating pressure	10 bar
Ambient temperature	0°C ... +40°C
Medium temperatures RED	+15°C ... +140°C
Medium temperatures GREEN 2	-20°C ... +90°C
Glycol proportion RED	≤25%
Glycol proportion GREEN 2	≤50%

Electrical data

VariA 40-15 440 4 1.5

Absorbed power P_2	1.50 kW
Nominale stroom	3.60 A

VariA 40-20 440 4 2.2

Absorbed power P_2	2.20 kW
Nominale stroom	4.90 A

VariA 40-23 440 4 3

Absorbed power P_2	3.00 kW
Nominale stroom	6.50 A
Efficiency class	IE3
Protection type	IP55
Insulation class	F
Voltage / frequency	3x400V / 50 Hz
Motor protection	CTP 150°C
Speed	1450 1/min

Connction diagram

Direct start-up

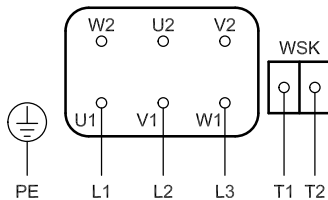

Y/Δ-start-up

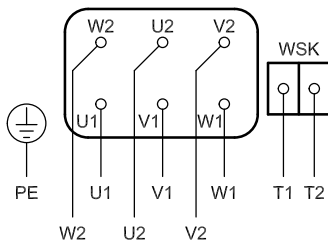

VariA... RED PN 16 without support

Art. No.

VariA 40-15 440 4 1.5	2210100150
VariA 40-20 440 4 2.2	2210110150
VariA 40-23 440 4 3	2210120150

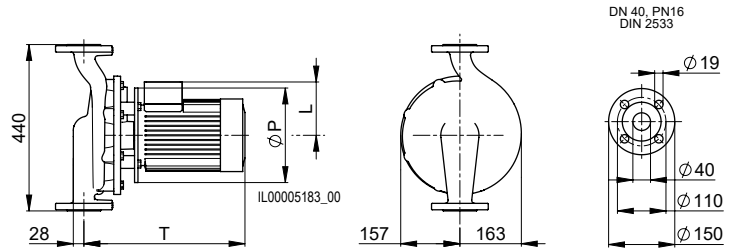

Type	T	P	L	Weight	Motor
VariA 40-15 440 4 1.5	401	200	132	47.0 kg	90L
VariA 40-20 440 4 2.2	473	250	155	51.0 kg	100L
VariA 40-23 440 4 3	473	250	155	54.0 kg	100L

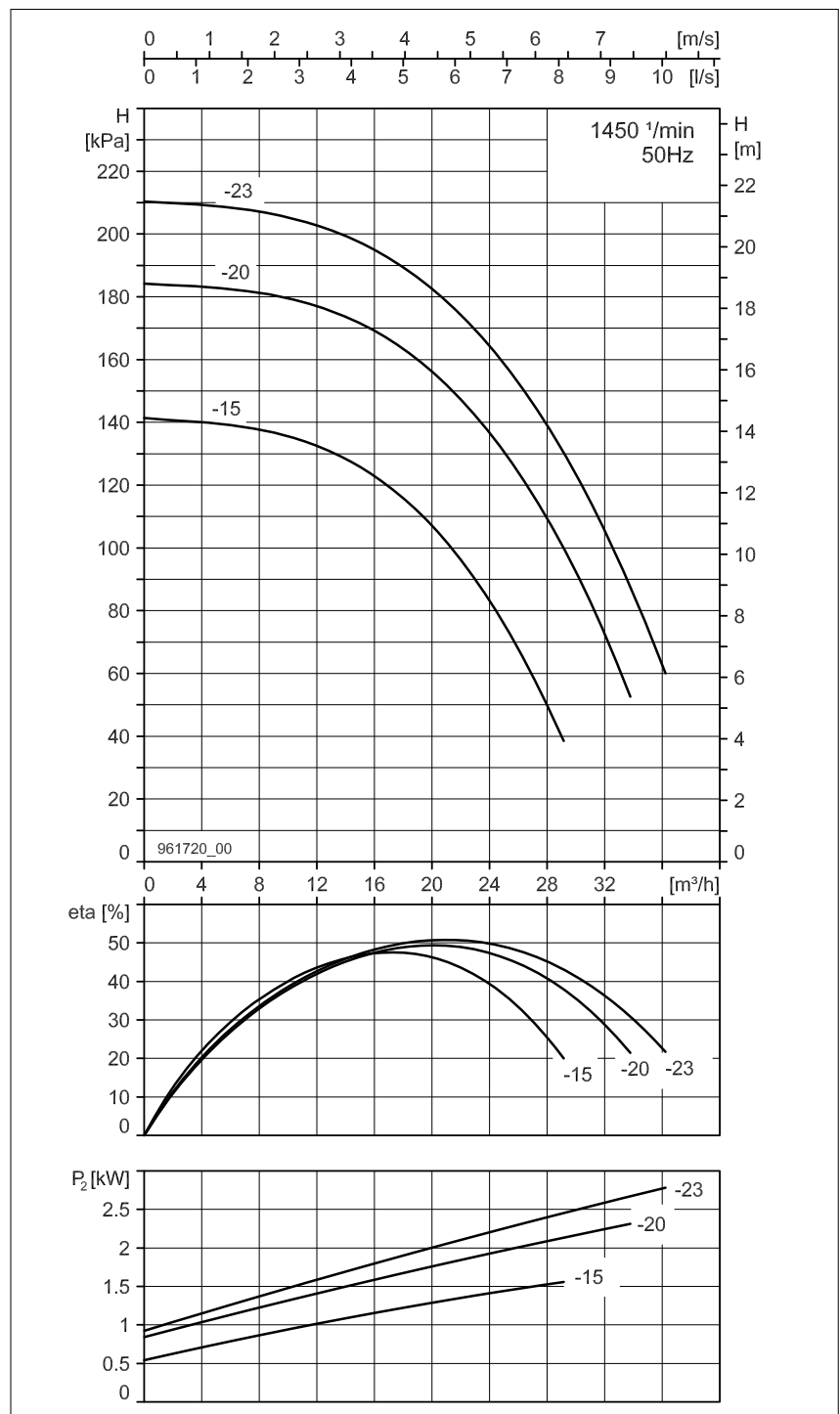

VariA 40-9 250 2 0.75
VariA 40-14 250 2 1.1
VariA 40-17 250 2 1.5

Nominal diameter	DN 40
Overall length	250 mm
Flanged connection	PN 16
Max. operating pressure	10 bar
Ambient temperature	0°C ... +40°C
Medium temperatures RED	+15°C ... +140°C
Medium temperatures GREEN 2	-20°C ... +90°C
Glycol proportion RED	≤25%
Glycol proportion GREEN 2	≤50%

Electrical data
VariA 40-9 250 2 0.75

Absorbed power P_2	0.75 kW
Nomiale stroom	1.70 A

VariA 40-14 250 2 1.1

Absorbed power P_2	1.10 kW
Nomiale stroom	2.20 A

VariA 40-17 250 2 1.5

Absorbed power P_2	1.50 kW
Nomiale stroom	3.10 A
Efficiency class	IE3
Protection type	IP55
Insulation class	F
Voltage / frequency	3x400V / 50 Hz
Motor protection	CTP 150°C
Speed	2900 1/min

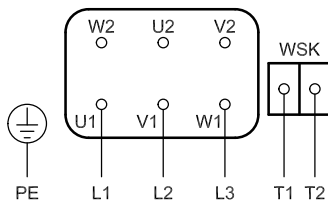
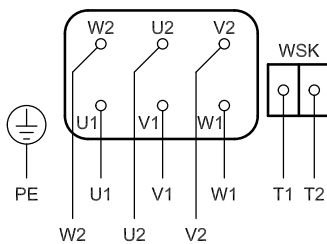
Connction diagram
Direct start-up

Y/Δ-start-up

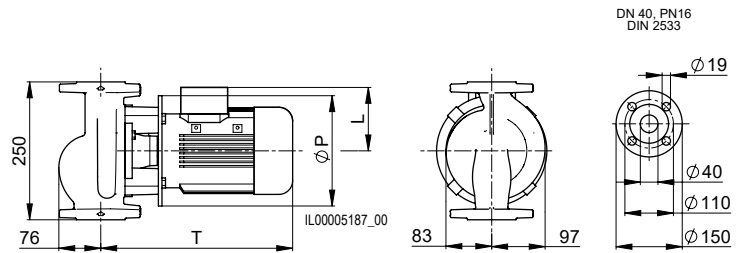
VariA... RED PN 16 without support
Art. No.

VariA 40-9 250 2 0.75	2210130150
VariA 40-14 250 2 1.1	2210140150
VariA 40-17 250 2 1.5	2210150150

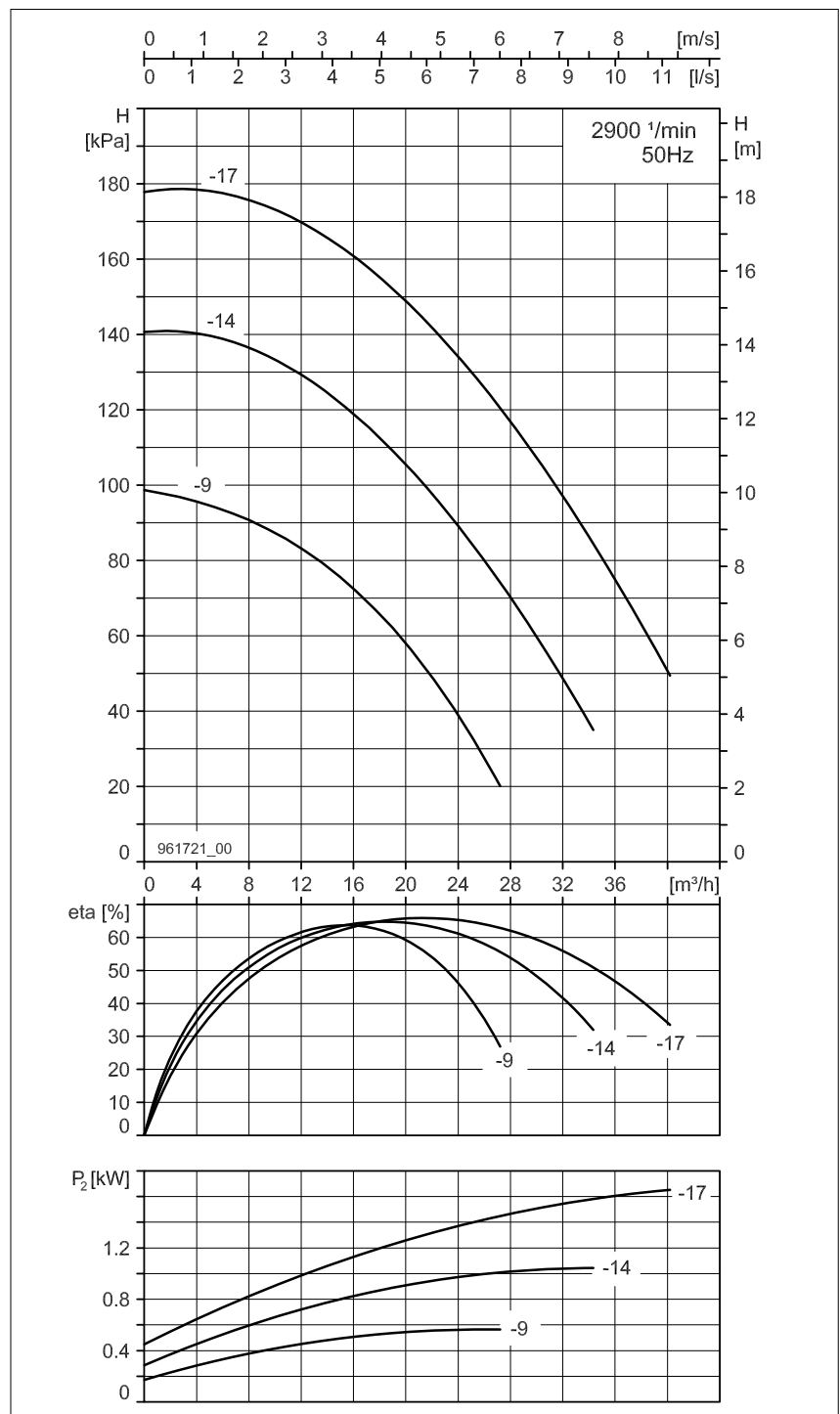

Type	T	P	L	Weight	Motor
VariA 40-9 250 2 0.75	348	200	115	22.5 kg	80M
VariA 40-14 250 2 1.1	348	200	115	23.5 kg	80M
VariA 40-17 250 2 1.5	351	200	132	27.5 kg	90S



VariA 40-18 340 2 2.2
VariA 40-23 340 2 3
VariA 40-30 340 2 4
VariA 40-38 340 2 5.5

Nominal diameter	DN 40
Overall length	340 mm
Flanged connection	PN 16
Max. operating pressure	10 bar
Ambient temperature	0°C ... +40°C
Medium temperatures RED	+15°C ... +140°C
Medium temperatures GREEN 2	-20°C ... +90°C
Glycol proportion RED	≤25%
Glycol proportion GREEN 2	≤50%

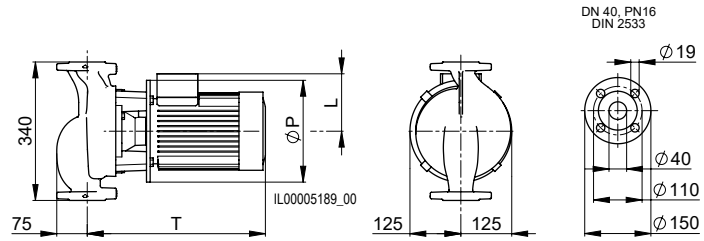

Type	T	P	L	Weight	Motor
VariA 40-18 340 2 2.2	391	200	132	38.5 kg	90L
VariA 40-23 340 2 3	485	250	150	45.0 kg	100L
VariA 40-30 340 2 4	481	250	149	51.0 kg	112M
VariA 40-38 340 2 5.5	506	300	182	64.5 kg	132S

Electrical data
VariA 40-18 340 2 2.2

Absorbed power P_2	2.20 kW
Nominale stroom	4.20 A

VariA 40-23 340 2 3

Absorbed power P_2	3.00 kW
Nominale stroom	5.50 A

VariA 40-30 340 2 4

Absorbed power P_2	4.00 kW
Nominale stroom	7.40 A

VariA 40-38 340 2 5.5

Absorbed power P_2	5.50 kW
Nominale stroom	9.70 A

Efficiency class	IE3
Protection type	IP55
Insulation class	F
Voltage / frequency	3x400V / 50 Hz
Motor protection	CTP 150°C
Speed	2900 1/min

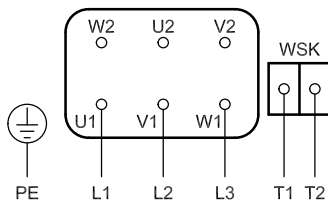
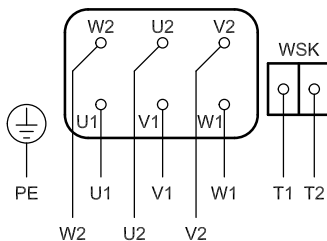
Connction diagram
Direct start-up

Y/Δ-start-up

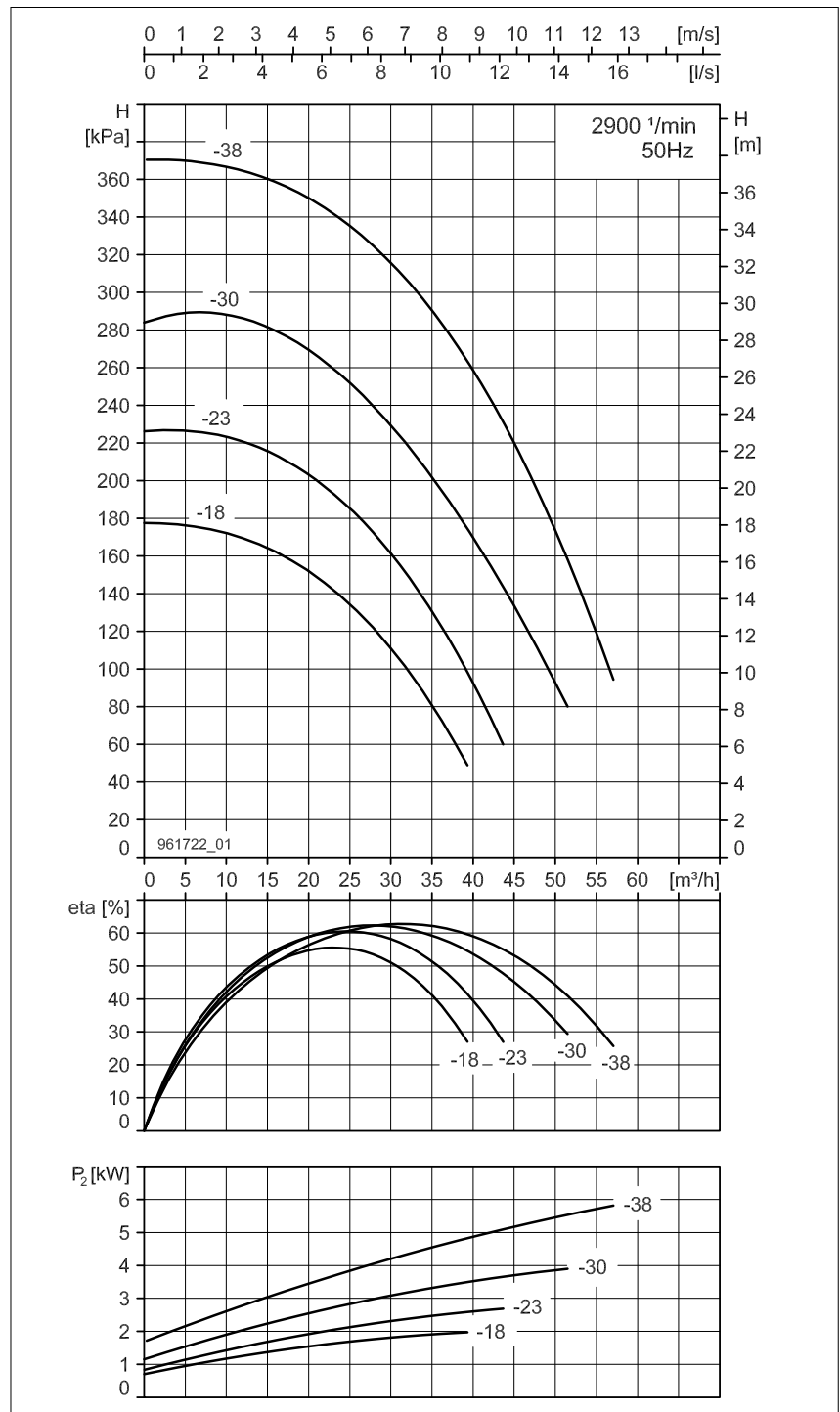
VariA... RED PN 16 without support
Art. No.

VariA 40-18 340 2 2.2	2210160150
VariA 40-23 340 2 3	2210170150
VariA 40-30 340 2 4	2210180150
VariA 40-38 340 2 5.5	2210190150



VariA 50-4.5 270 4 0.25
VariA 50-5.5 270 4 0.37
VariA 50-7 270 4 0.55

Nominal diameter	DN 50
Overall length	270 mm
Flanged connection	PN 16
Max. operating pressure	10 bar
Ambient temperature	0°C ... +40°C
Medium temperatures RED	+15°C ... +140°C
Medium temperatures GREEN 2	-20°C ... +90°C
Glycol proportion RED	≤25%
Glycol proportion GREEN 2	≤50%

Electrical data
VariA 50-4.5 270 4 0.25

Absorbed power P_2	0.25 kW
Nominale stroom	0.81 A

VariA 50-5.5 270 4 0.37

Absorbed power P_2	0.37 kW
Nominale stroom	1.05 A

VariA 50-7 270 4 0.55

Absorbed power P_2	0.55 kW
Nominale stroom	1.42 A
Efficiency class	IE3
Protection type	IP55
Insulation class	F
Voltage / frequency	3x400V / 50 Hz
Motor protection	CTP 150°C
Speed	1450 1/min

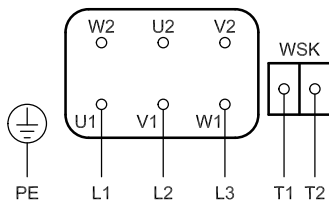
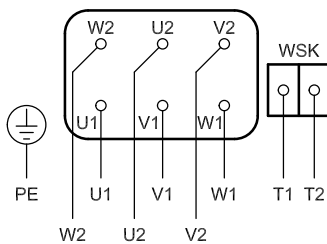
Connction diagram
Direct start-up

Y/Δ-start-up

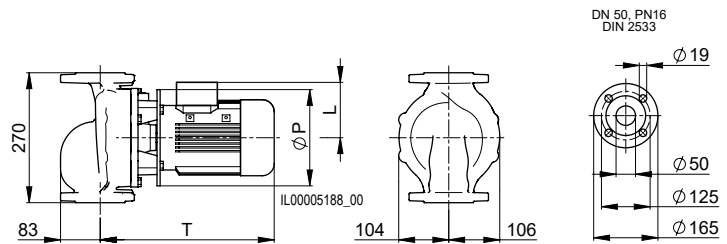
VariA... RED PN 16 without support
Art. No.

VariA 50-4.5 270 4 0.25	2210200150
VariA 50-5.5 270 4 0.37	2210210150
VariA 50-7 270 4 0.55	2210220150

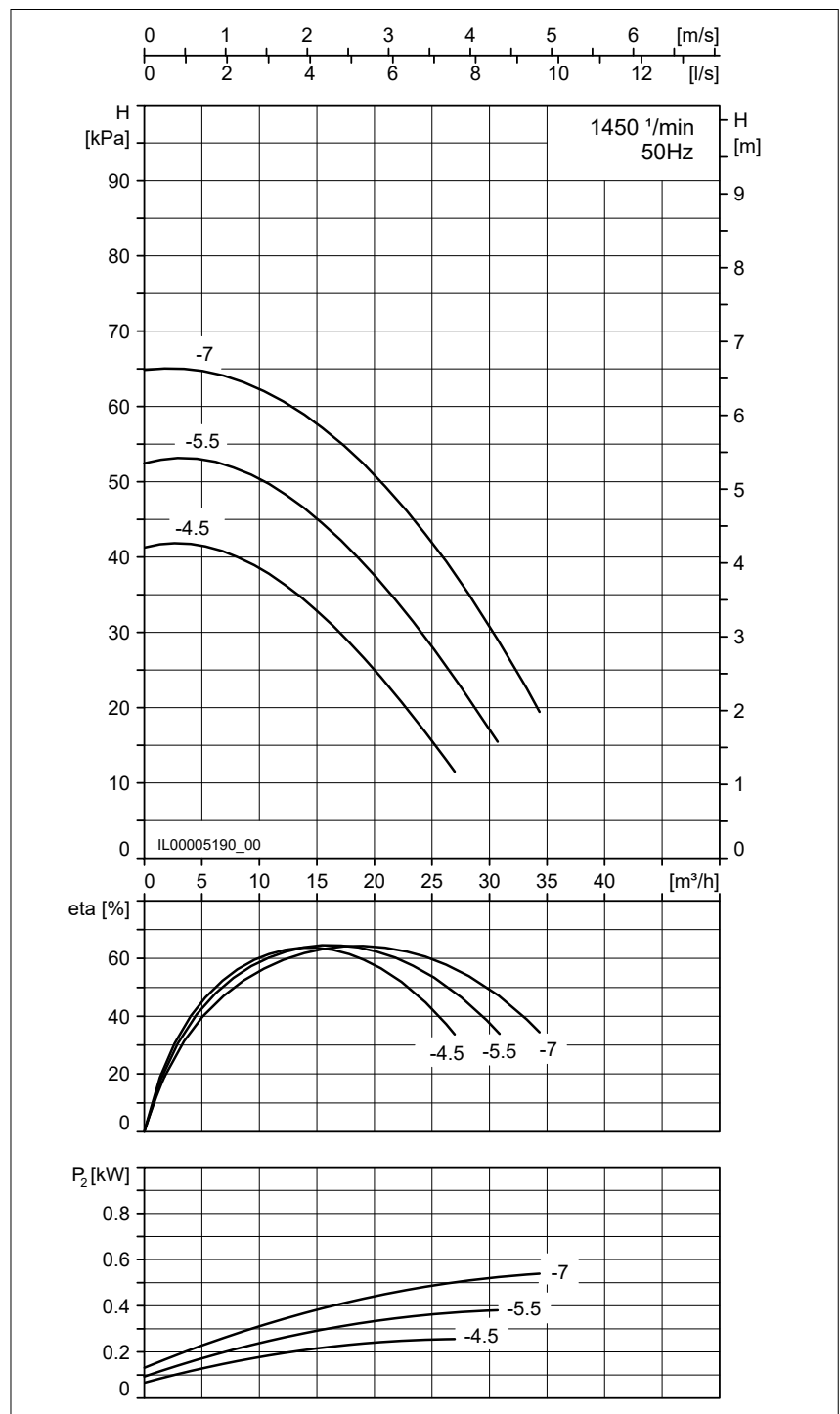

Type	T	P	L	Weight	Motor
VariA 50-4.5 270 4 0.25	341	160	107	25.5 kg	71M
VariA 50-5.5 270 4 0.37	341	160	107	26.5 kg	71M
VariA 50-7 270 4 0.55	362	200	115	29.0 kg	80M



VariA 50-16 440 4 2.2
VariA 50-20 440 4 3
VariA 50-23 440 4 4

Nominal diameter	DN 50
Overall length	440 mm
Flanged connection	PN 16
Max. operating pressure	10 bar
Ambient temperature	0°C ... +40°C
Medium temperatures RED	+15°C ... +140°C
Medium temperatures GREEN 2	-20°C ... +90°C
Glycol proportion RED	≤25%
Glycol proportion GREEN 2	≤50%

Electrical data
VariA 50-16 440 4 2.2

Absorbed power P_2	2.20 kW
Nominale stroom	4.90 A

VariA 50-20 440 4 3

Absorbed power P_2	3.00 kW
Nominale stroom	6.50 A

VariA 50-23 440 4 4

Absorbed power P_2	4.00 kW
Nominale stroom	8.30 A
Efficiency class	IE3
Protection type	IP55
Insulation class	F
Voltage / frequency	3x400V / 50 Hz
Motor protection	CTP 150°C
Speed	1450 1/min

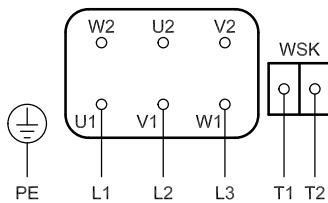
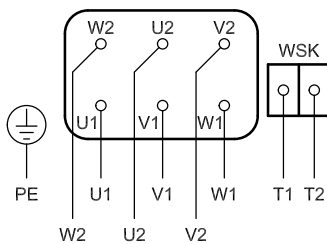
Connction diagram
Direct start-up

Y/Δ-start-up

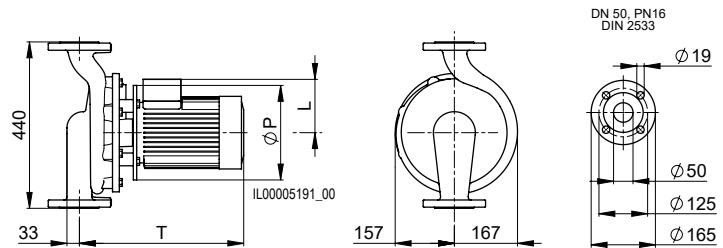
VariA... RED PN 16 without support
Art. No.

VariA 50-16 440 4 2.2	2210240150
VariA 50-20 440 4 3	2210250150
VariA 50-23 440 4 4	2210260150

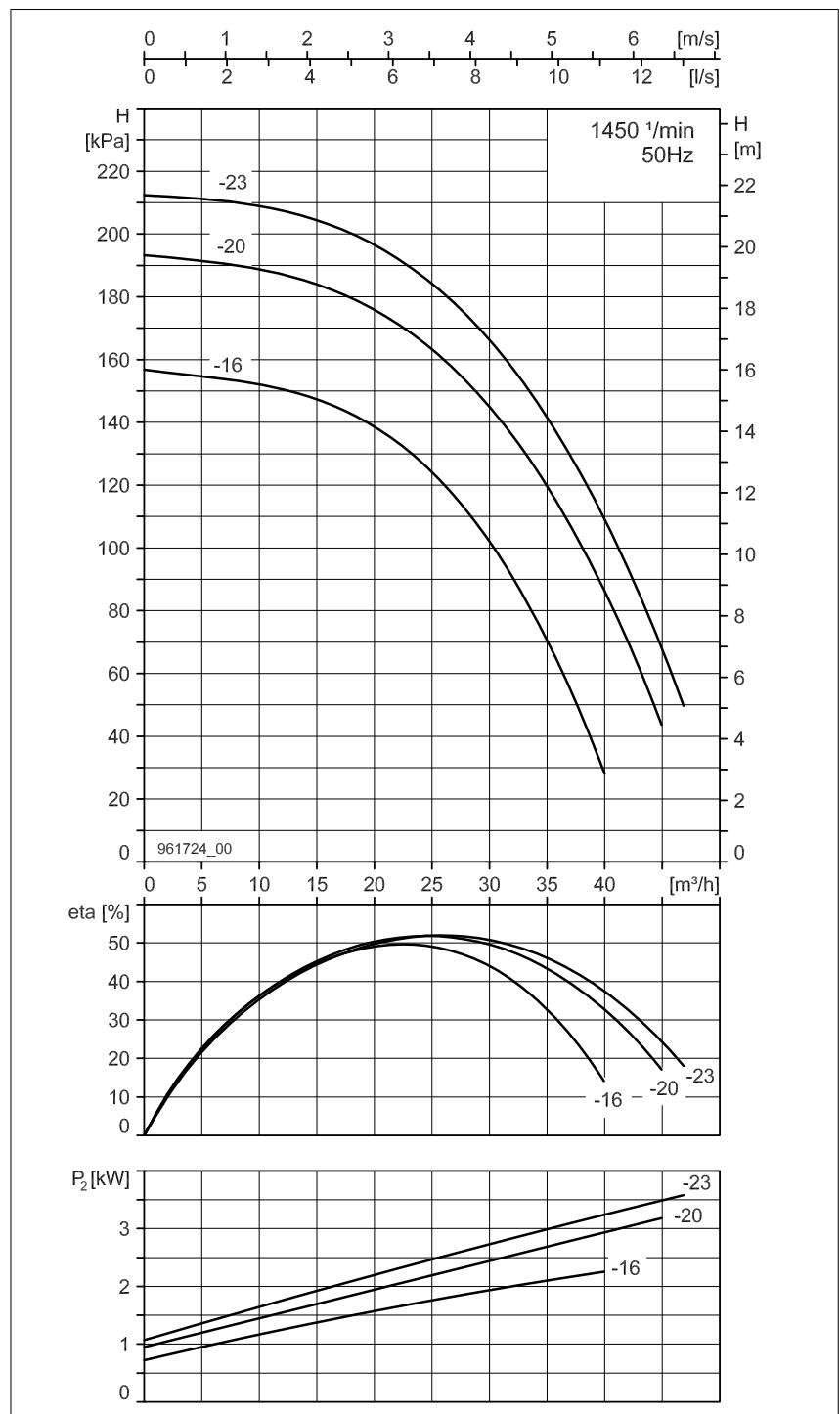

Type	T	P	L	Weight	Motor
VariA 50-16 440 4 2.2	482	250	155	54.0 kg	100L
VariA 50-20 440 4 3	482	250	155	57.0 kg	100L
VariA 50-23 440 4 4	478	250	149	64.0 kg	112M



VariA 50-15 270 2 1.5
VariA 50-18 270 2 2.2
VariA 50-22 270 2 3
VariA 50-28 270 2 4

Nominal diameter	DN 50
Overall length	270 mm
Flanged connection	PN 16
Max. operating pressure	10 bar
Ambient temperature	0°C ... +40°C
Medium temperatures RED	+15°C ... +140°C
Medium temperatures GREEN 2	-20°C ... +90°C
Glycol proportion RED	≤25%
Glycol proportion GREEN 2	≤50%

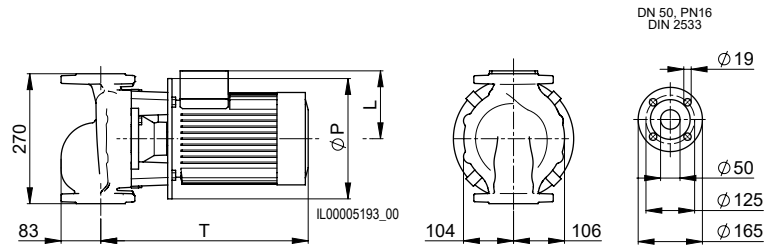

Type	T	P	L	Weight	Motor
VariA 50-15 270 2 1.5	365	200	132	34.0 kg	90S
VariA 50-18 270 2 2.2	385	200	132	38.5 kg	90L
VariA 50-22 270 2 3	478	250	155	42.5 kg	100L
VariA 50-28 270 2 4	475	250	149	48.5 kg	112M

Electrical data
VariA 50-15 270 2 1.5

Absorbed power P_2	1.50 kW
Nominale stroom	3.10 A

VariA 50-18 270 2 2.2

Absorbed power P_2	2.20 kW
Nominale stroom	4.20 A

VariA 50-22 270 2 3

Absorbed power P_2	3.00 kW
Nominale stroom	5.50 A

VariA 50-28 270 2 4

Absorbed power P_2	4.00 kW
Nominale stroom	7.40 A

Efficiency class	IE3
Protection type	IP55
Insulation class	F
Voltage / frequency	3x400V / 50 Hz
Motor protection	CTP 150°C
Speed	2900 1/min

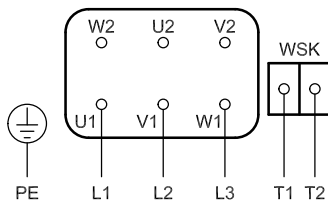
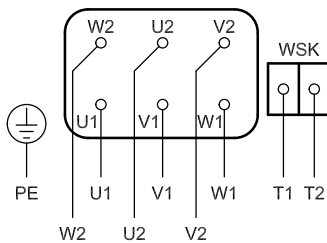
Connction diagram
Direct start-up

Y/Δ-start-up

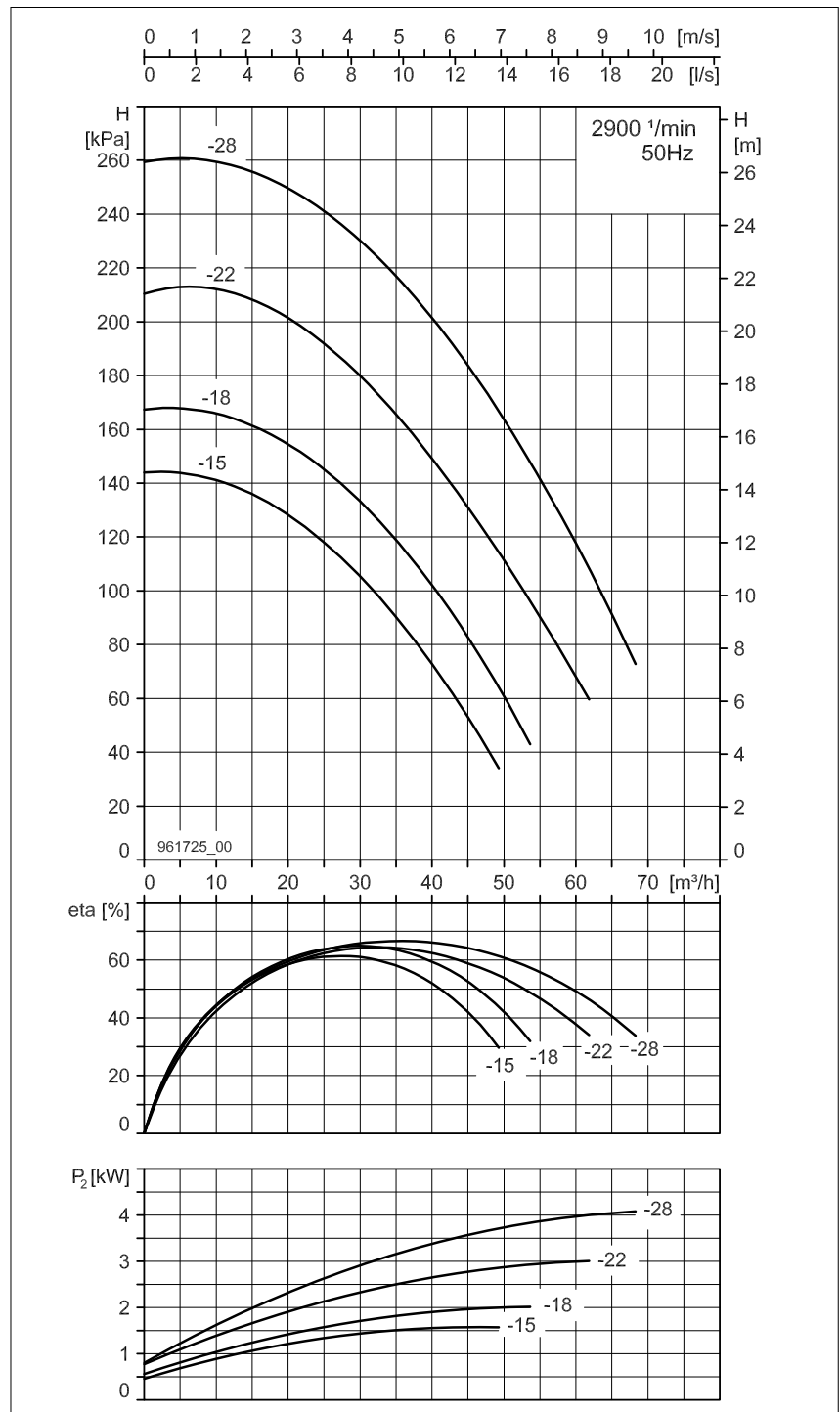
VariA... RED PN 16 without support	Art. No.
VariA 50-15 270 2 1.5	2210270150
VariA 50-18 270 2 2.2	2210280150
VariA 50-22 270 2 3	2210290150
VariA 50-28 270 2 4	2210300150

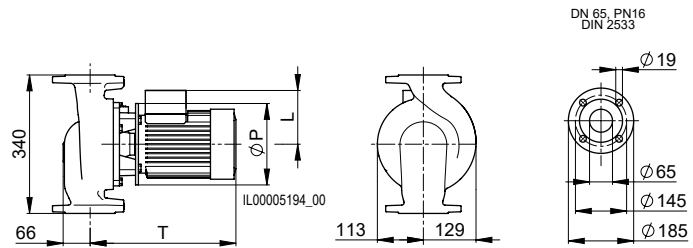

VariA 65-5.5 340 4 0.55
VariA 65-7 340 4 0.75
VariA 65-8.5 340 4 1.1
VariA 65-10 340 4 1.5

Nominal diameter	DN 65
Overall length	340 mm
Flanged connection	PN 16
Max. operating pressure	10 bar
Ambient temperature	0°C ... +40°C
Medium temperatures RED	+15°C ... +140°C
Medium temperatures GREEN 2	-20°C ... +90°C
Glycol proportion RED	≤25%
Glycol proportion GREEN 2	≤50%



Flanges EN 1092-2 on request

Type	T	P	L	Weight	Motor
VariA 65-5.5 340 4 0.55	355	200	115	32.0 kg	80M
VariA 65-7 340 4 0.75	355	200	115	33.5 kg	80M
VariA 65-8.5 340 4 1.1	358	200	132	37.0 kg	90S
VariA 65-10 340 4 1.5	378	200	132	39.0 kg	90L

Electrical data
VariA 65-5.5 340 4 0.55

Absorbed power P_2	0.55 kW
Nominale stroom	1.42 A

VariA 65-7 340 4 0.75

Absorbed power P_2	0.75 kW
Nominale stroom	1.90 A

VariA 65-8.5 340 4 1.1

Absorbed power P_2	1.10 kW
Nominale stroom	2.30 A

VariA 65-10 340 4 1.5

Absorbed power P_2	1.50 kW
Nominale stroom	3.60 A

Efficiency class	IE3
Protection type	IP55
Insulation class	F
Voltage / frequency	3x400V / 50 Hz
Motor protection	CTP 150°C
Speed	1450 1/min

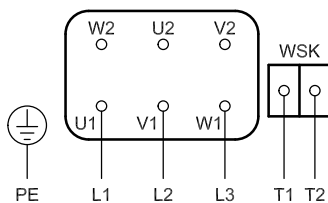
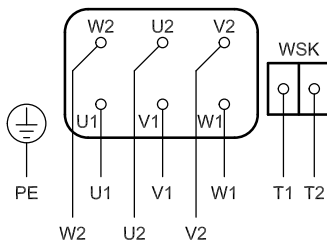
Connction diagram
Direct start-up

Y/Δ-start-up

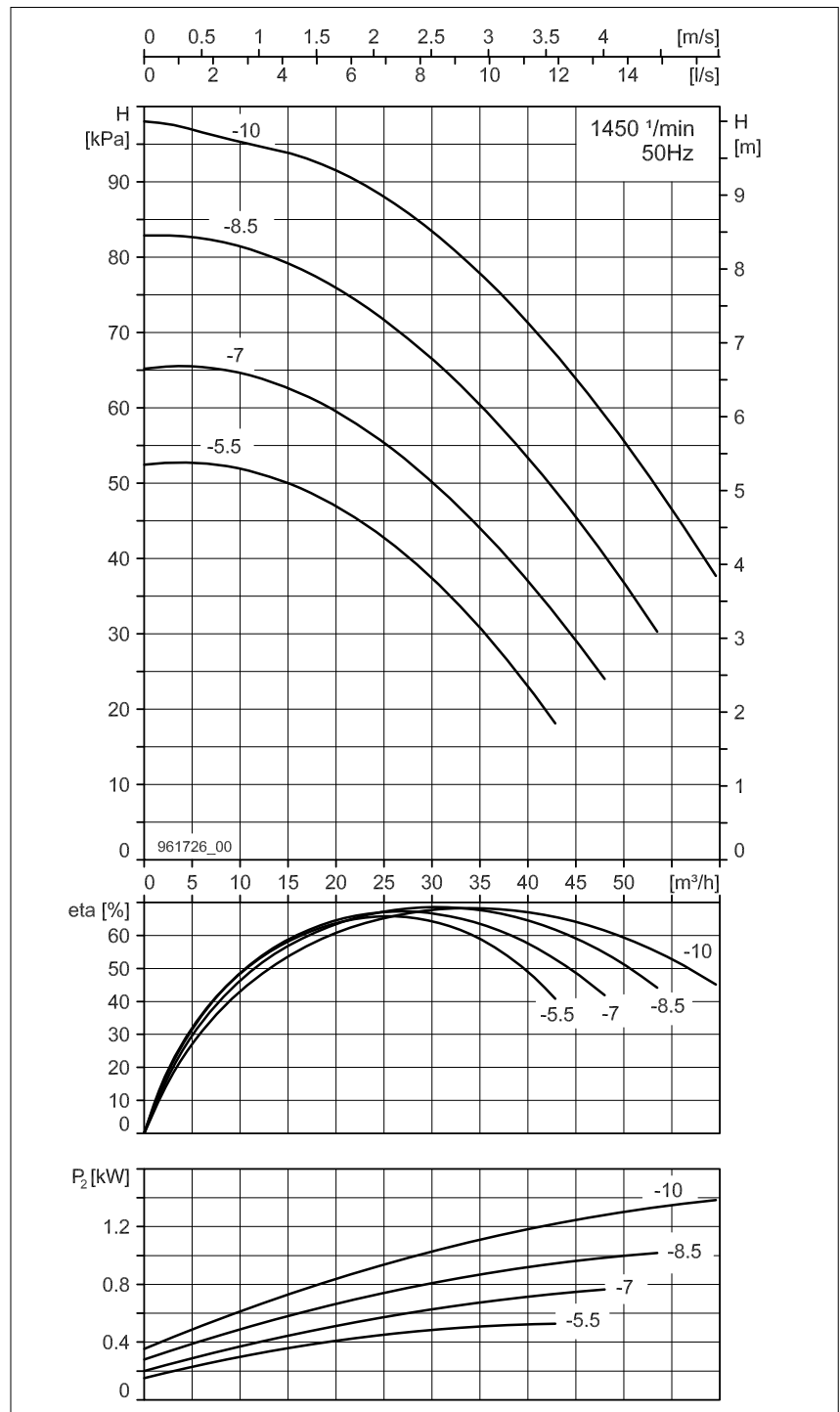
VariA... RED PN 16 without support
Art. No.

VariA 65-5.5 340 4 0.55	2210310150
VariA 65-7 340 4 0.75	2210320150
VariA 65-8.5 340 4 1.1	2210330150
VariA 65-10 340 4 1.5	2210340150



VariA 65-12 475 4 2.2
VariA 65-15 475 4 3
VariA 65-17 475 4 4
VariA 65-22 475 4 5.5

Nominal diameter	DN 65
Overall length	475 mm
Flanged connection	PN 16
Max. operating pressure	10 bar
Ambient temperature	0°C ... +40°C
Medium temperatures RED	+15°C ... +140°C
Medium temperatures GREEN 2	-20°C ... +90°C
Glycol proportion RED	≤25%
Glycol proportion GREEN 2	≤50%

Electrical data

VariA 65-12 475 4 2.2	
Absorbed power P ₂	2.20 kW
Nominale stroom	4.90 A
VariA 65-15 475 4 3	
Absorbed power P ₂	3.00 kW
Nominale stroom	6.50 A
VariA 65-17 475 4 4	
Absorbed power P ₂	4.00 kW
Nominale stroom	8.30 A
VariA 65-22 475 4 5.5	
Absorbed power P ₂	5.50 kW
Nominale stroom	11.10 A
Efficiency class	IE3
Protection type	IP55
Insulation class	F
Voltage / frequency	3x400V / 50 Hz
Motor protection	CTP 150°C
Speed	1450 1/min

Connction diagram

Direct start-up

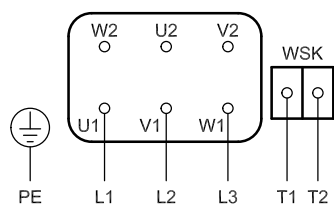

Y/Δ-start-up

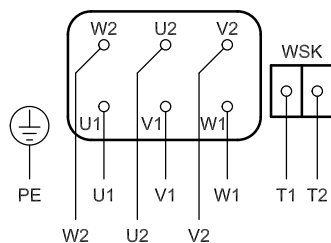

VariA... RED PN 16 without support	Art. No.
VariA 65-12 475 4 2.2	2210350150
VariA 65-15 475 4 3	2210360150
VariA 65-17 475 4 4	2210370150
VariA 65-22 475 4 5.5	2210380150

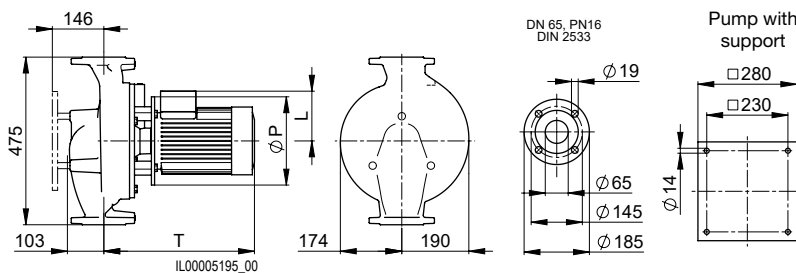

Flanges EN 1092-2 on request

Type	T	P	L	Weight	Motor
VariA 65-12 475 4 2.2	474	250	155	72.0 kg	100L
VariA 65-15 475 4 3	474	250	155	75.0 kg	100L
VariA 65-17 475 4 4	470	250	149	82.0 kg	112M
VariA 65-22 475 4 5.5	495	300	182	95.5 kg	132S

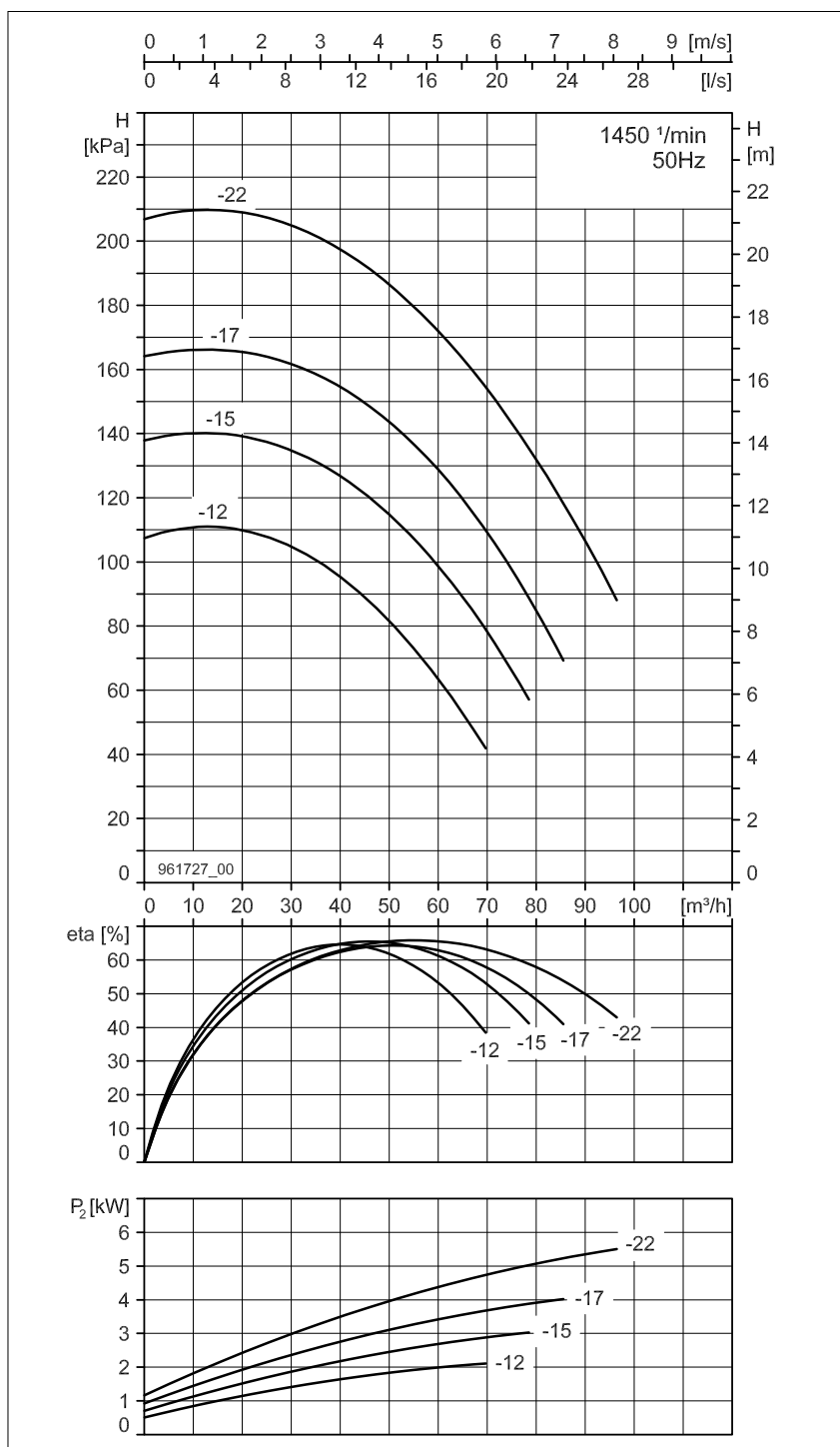

VariA 65-21 340 2 4
VariA 65-27 340 2 5.5
VariA 65-34 340 2 7.5

Nominal diameter	DN 65
Overall length	340 mm
Flanged connection	PN 16
Max. operating pressure	10 bar
Ambient temperature	0°C ... +40°C
Medium temperatures RED	+15°C ... +140°C
Medium temperatures GREEN 2	-20°C ... +90°C
Glycol proportion RED	≤25%
Glycol proportion GREEN 2	≤50%

Electrical data
VariA 65-21 340 2 4

Absorbed power P_2	4.00 kW
Nominale stroom	7.40 A

VariA 65-27 340 2 5.5

Absorbed power P_2	5.50 kW
Nominale stroom	9.70 A

VariA 65-34 340 2 7.5

Absorbed power P_2	7.50 kW
Nominale stroom	13.20 A
Efficiency class	IE3
Protection type	IP55
Insulation class	F
Voltage / frequency	3x400V / 50 Hz
Motor protection	CTP 150°C
Speed	2900 1/min

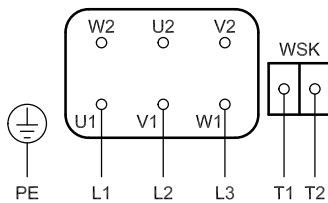
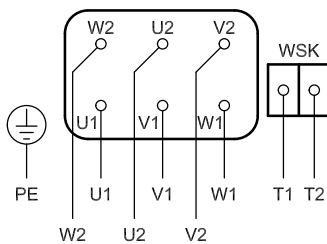
Connction diagram
Direct start-up

Y/Δ-start-up

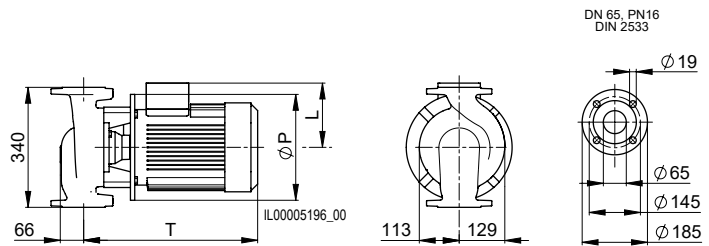
VariA... RED PN 16 without support
Art. No.

VariA 65-21 340 2 4	2210390150
VariA 65-27 340 2 5.5	2210400150
VariA 65-34 340 2 7.5	2210410150

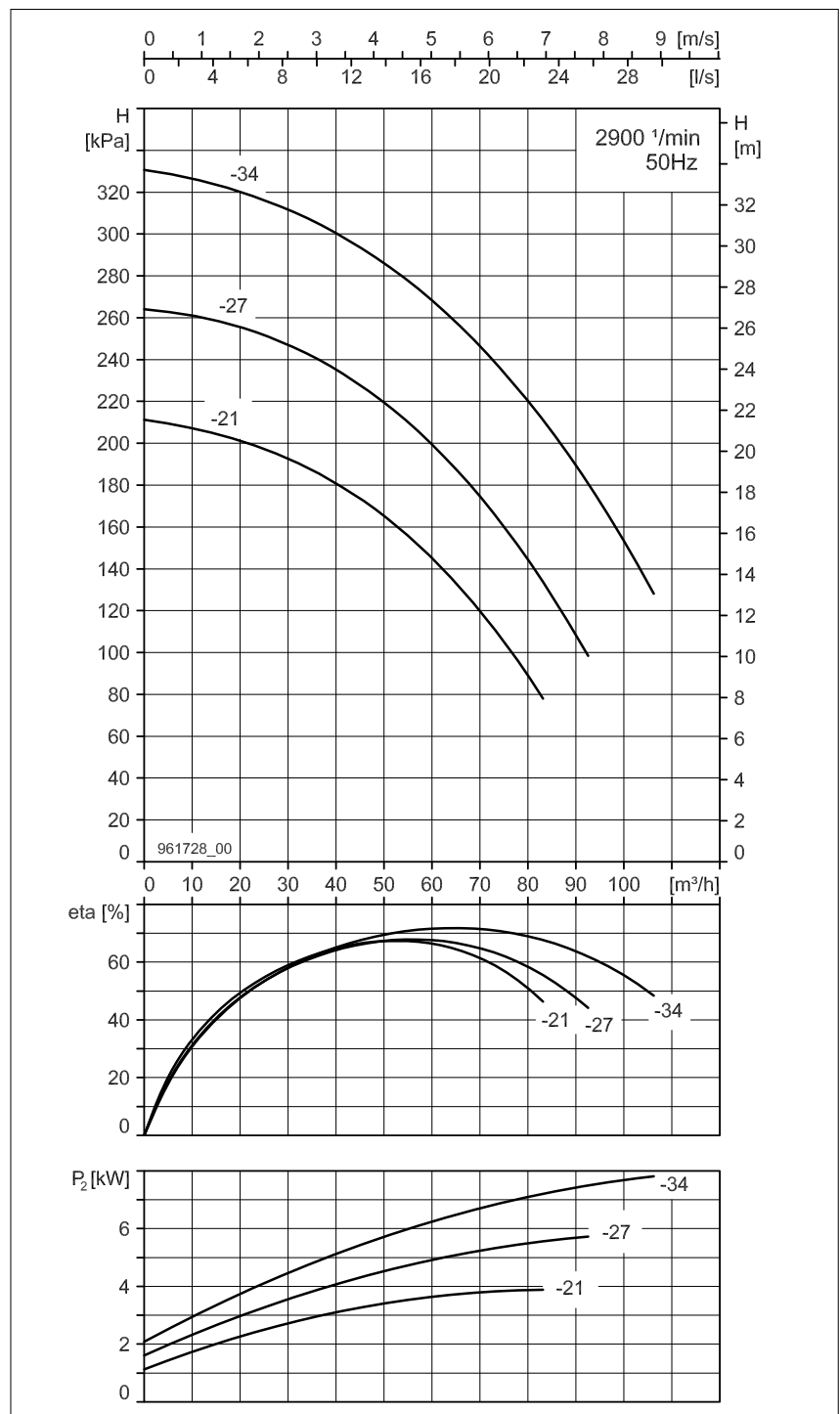

Type	T	P	L	Weight	Motor
VariA 65-21 340 2 4	468	250	149	51.5 kg	112M
VariA 65-27 340 2 5.5	493	300	182	65.5 kg	132S
VariA 65-34 340 2 7.5	493	300	182	72.5 kg	132S



VariA 80-7 400 4 1.1
VariA 80-8.5 400 4 1.5
VariA 80-10 400 4 2.2
VariA 80-14 400 4 3

Nominal diameter	DN 80
Overall length	400 mm
Flanged connection	PN 16 (Auf Anfrage PN6)
Max. operating pressure	10 bar
Ambient temperature	0°C ... +40°C
Medium temperatures RED	+15°C ... +140°C
Medium temperatures GREEN 2	-20°C ... +90°C
Glycol proportion RED	≤25%
Glycol proportion GREEN 2	≤50%

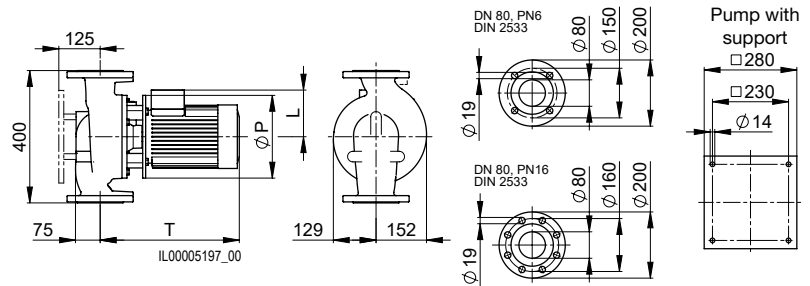

Type	T	P	L	Weight	Motor
VariA 80-7 400 4 1.1	375	200	132	49.0 kg	90S
VariA 80-8.5 400 4 1.5	395	200	132	51.0 kg	90L
VariA 80-10 400 4 2.2	468	250	155	55.5 kg	100L
VariA 80-14 400 4 3	468	250	155	58.5 kg	100L

Electrical data
VariA 80-7 400 4 1.1

Absorbed power P_2	1.10 kW
Nominale stroom	2.30 A

VariA 80-8.5 400 4 1.5

Absorbed power P_2	1.50 kW
Nominale stroom	3.60 A

VariA 80-10 400 4 2.2

Absorbed power P_2	2.20 kW
Nominale stroom	4.90 A

VariA 80-14 400 4 3

Absorbed power P_2	3.0 kW
Nominale stroom	6.50 A

Efficiency class	IE3
Protection type	IP55
Insulation class	F
Voltage / frequency	3x400V / 50 Hz
Motor protection	CTP 150°C
Speed	1450 1/min

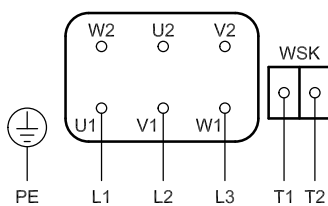
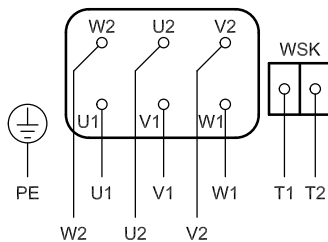
Connction diagram
Direct start-up

Y/Δ-start-up

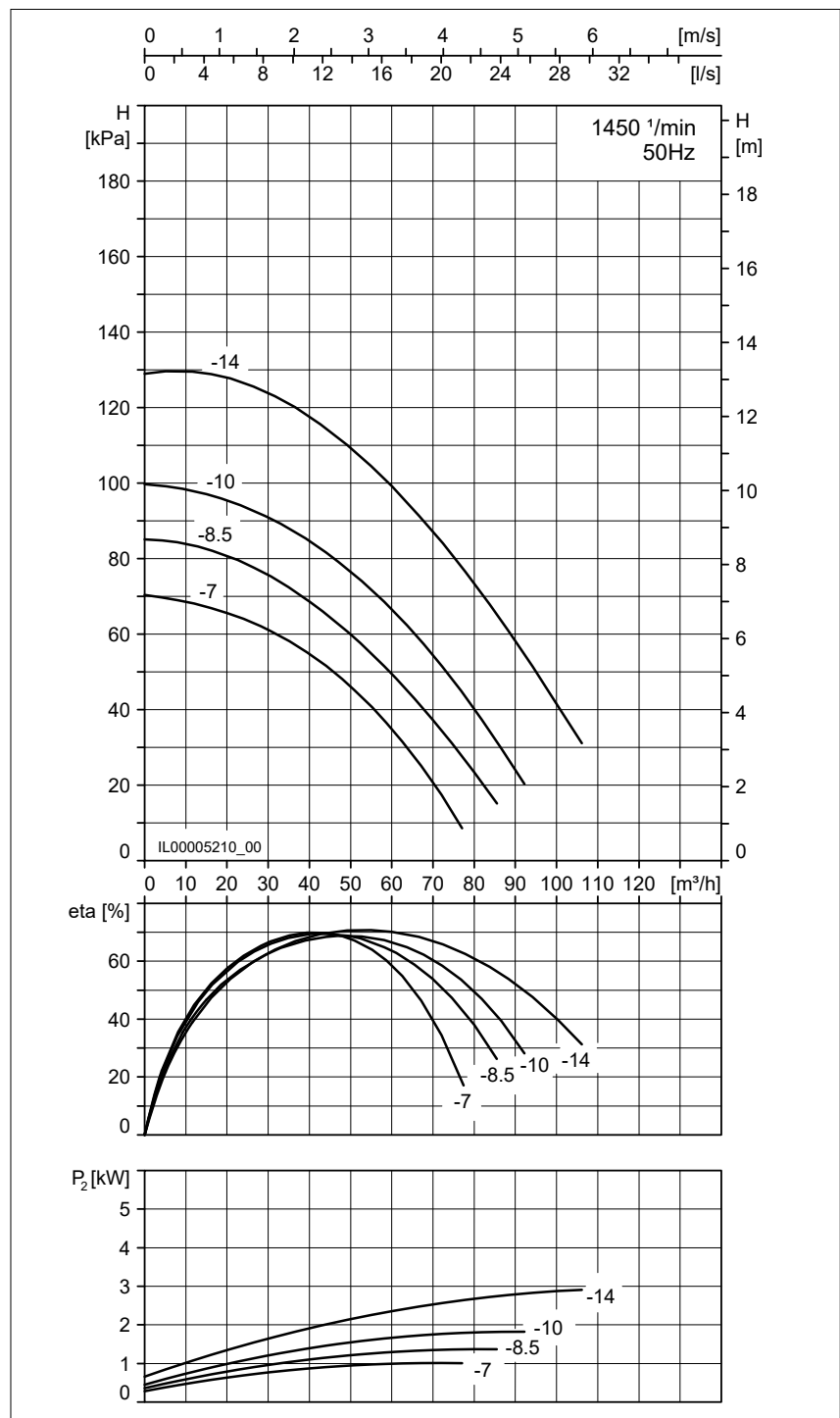
VariA... RED PN 16 without support	Art. No.
VariA 80-7 400 4 1.1	2210420150
VariA 80-8.5 400 4 1.5	2210430150
VariA 80-10 400 4 2.2	2210440150
VariA 80-14 400 4 3	2210450150



VariA 80-13 500 4 3
VariA 80-16 500 4 4
VariA 80-19 500 4 5.5
VariA 80-23 500 4 7.5

Nominal diameter	DN 80
Overall length	500 mm
Flanged connection	PN 16
Max. operating pressure	10 bar
Ambient temperature	0°C ... +40°C
Medium temperatures RED	+15°C ... +140°C
Medium temperatures GREEN 2	-20°C ... +90°C
Glycol proportion RED	≤25%
Glycol proportion GREEN 2	≤50%

Electrical data
VariA 80-13 500 4 3

Absorbed power P_2	3.00 kW
Nominale stroom	6.50 A

VariA 80-16 500 4 4

Absorbed power P_2	4.00 kW
Nominale stroom	8.30 A

VariA 80-19 500 4 5.5

Absorbed power P_2	5.50 kW
Nominale stroom	11.10 A

VariA 80-23 500 4 7.5

Absorbed power P_2	7.50 kW
Nominale stroom	14.90 A

Efficiency class	IE3
Protection type	IP55
Insulation class	F
Voltage / frequency	3x400V / 50 Hz
Motor protection	CTP 150°C
Speed	1450 1/min

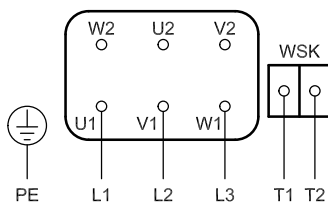
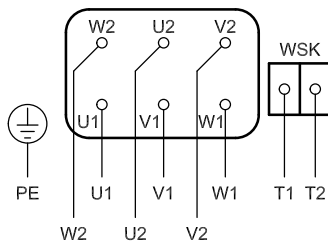
Connction diagram
Direct start-up

Y/Δ-start-up

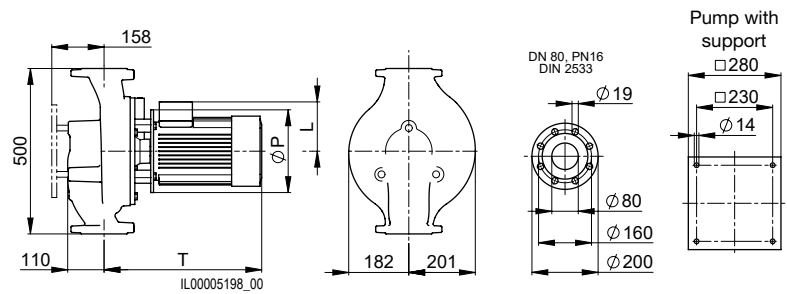
VariA... RED PN 16 without support
Art. No.

VariA 80-13 500 4 3	2210480150
VariA 80-16 500 4 4	2210490150
VariA 80-19 500 4 5.5	2210500150
VariA 80-23 500 4 7.5	2210510150

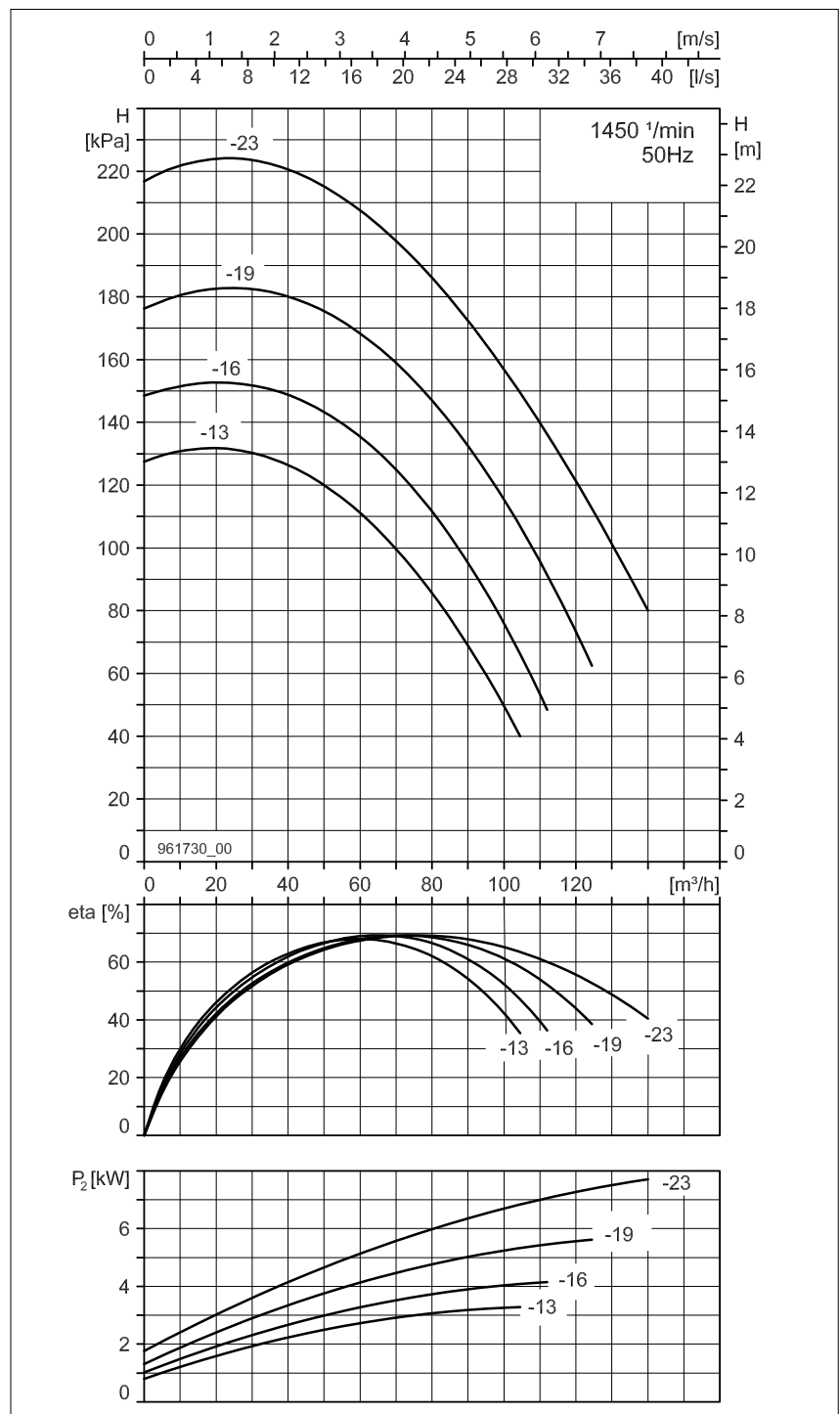

Type	T	P	L	Weight	Motor
VariA 80-13 500 4 3	480	250	155	81.5 kg	100L
VariA 80-16 500 4 4	477	250	149	88.5 kg	112M
VariA 80-19 500 4 5.5	502	300	182	102.0 kg	132S
VariA 80-23 500 4 7.5	537	300	182	113.0 kg	132M



VariA 100-8 450 4 2.2
VariA 100-10 450 4 3
VariA 100-11.5 450 4 4
VariA 100-14 450 4 5.5

Nominal diameter	DN 100
Overall length	450 mm
Flanged connection	PN 16 (Auf Anfrage PN 6)
Max. operating pressure	10 bar
Ambient temperature	0°C ... +40°C
Medium temperatures RED	+15°C ... +140°C
Medium temperatures GREEN 2	-20°C ... +90°C
Glycol proportion RED	≤25%
Glycol proportion GREEN 2	≤50%

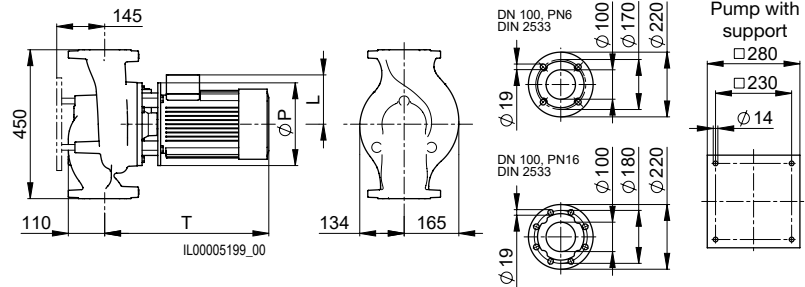

Type	T	P	L	Weight	Motor
VariA 100-8 450 4 2.2	500	250	155	67.0 kg	100L
VariA 100-10 450 4 3	500	250	155	70.0 kg	100L
VariA 100-11.5 450 4 4	496	250	149	77.0 kg	112M
VariA 100-14 450 4 5.5	521	300	182	90.5 kg	132S

Electrical data
VariA 100-8 450 4 2.2

Absorbed power P_2	2.20 kW
Nominale stroom	4.90 A

VariA 100-10 450 4 3

Absorbed power P_2	3.00 kW
Nominale stroom	6.50 A

VariA 100-11.5 450 4 4

Absorbed power P_2	4.00 kW
Nominale stroom	8.30 A

VariA 100-14 450 4 5.5

Absorbed power P_2	5.50 kW
Nominale stroom	11.10 A

Efficiency class	IE3
Protection type	IP55
Insulation class	F
Voltage / frequency	3x400V / 50 Hz
Motor protection	CTP 150°C
Speed	1450 1/min

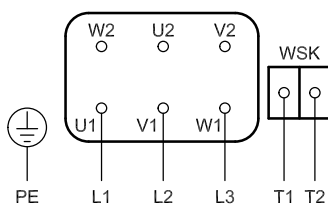
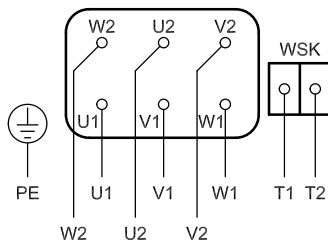
Connction diagram
Direct start-up

Y/Δ-start-up

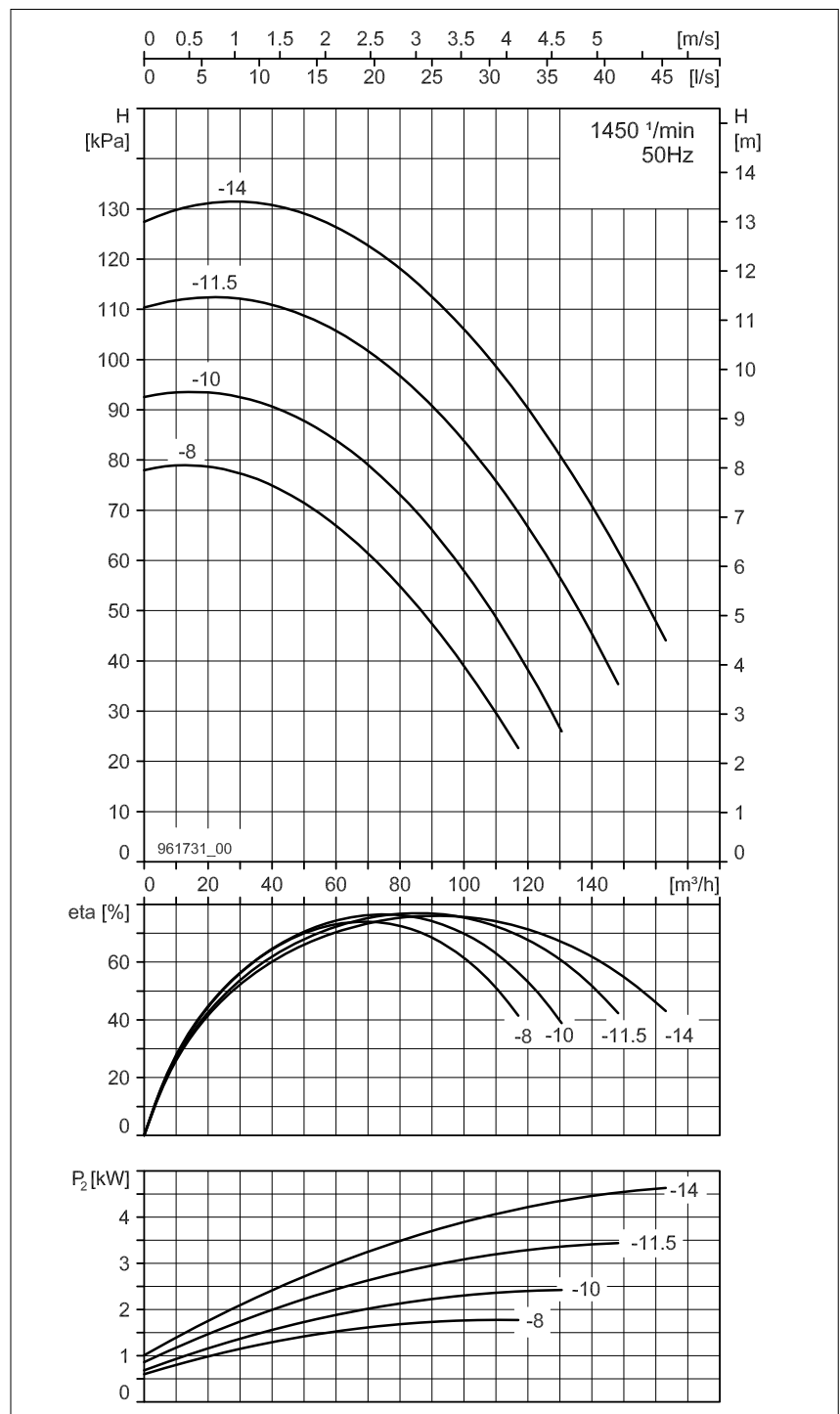
VariA... RED PN 16 without support

VariA...	Art. No.
VariA 100-8 450 4 2.2	2210520150
VariA 100-10 450 4 3	2210530150
VariA 100-11.5 450 4 4	2210540150
VariA 100-14 450 4 5.5	2210550150



VariA 100-16 670 4 5.5
VariA 100-19 670 4 7.5
VariA 100-25 670 4 11

Nominal diameter	DN 100
Overall length	670 mm
Flanged connection	PN 16
Max. operating pressure	10 bar
Ambient temperature	0°C ... +40°C
Medium temperatures RED	+15°C ... +140°C
Medium temperatures GREEN 2	-20°C ... +90°C
Glycol proportion RED	≤25%
Glycol proportion GREEN 2	≤50%

Electrical data
VariA 100-16 670 4 5.5

Absorbed power P_2	5.50 kW
Nominale stroom	11.10 A

VariA 100-19 670 4 7.5

Absorbed power P_2	7.50 kW
Nominale stroom	14.90 A

VariA 100-25 670 4 11

Absorbed power P_2	11.00 kW
Nominale stroom	22.00 A
Efficiency class	IE3
Protection type	IP55
Insulation class	F
Voltage / frequency	3x400V / 50 Hz
Motor protection	CTP 150°C
Speed	1450 1/min

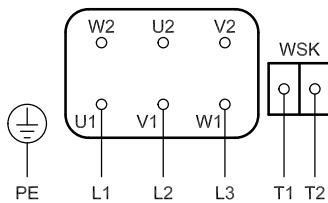
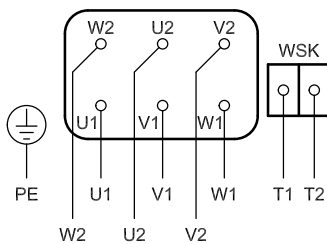
Connction diagram
Direct start-up

Y/Δ-start-up

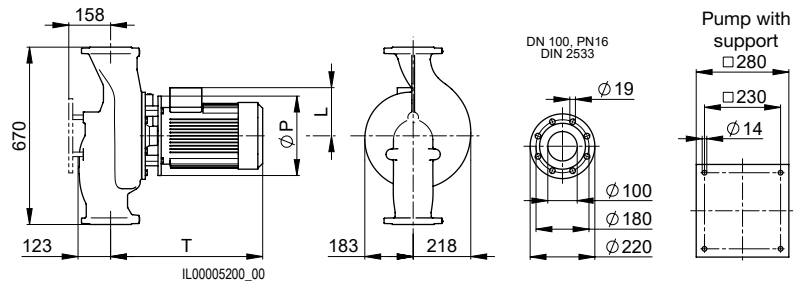
VariA... RED PN 16 without support
Art. No.

VariA 100-16 670 4 5.5	2210570150
VariA 100-19 670 4 7.5	2210580150
VariA 100-25 670 4 11	2210590150

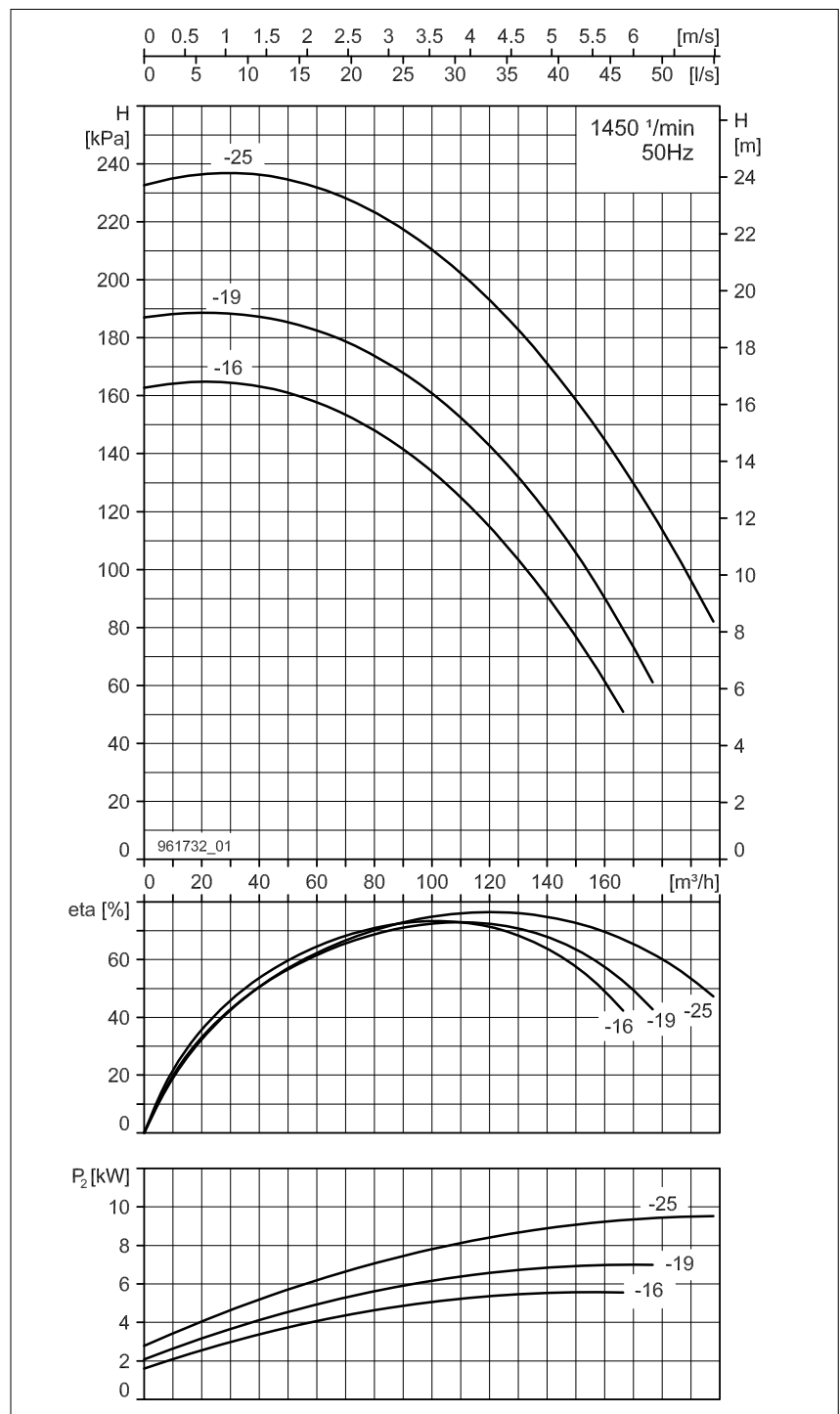

Type	T	P	L	Weight	Motor
VariA 100-16 670 4 5.5	540	300	182	123.0 kg	132S
VariA 100-19 670 4 7.5	575	300	182	134.0 kg	132M
VariA 100-25 670 4 11	655	350	200	157.5 kg	160M



VariA 125-12.5 620 4 4
VariA 125-15 620 4 5.5
VariA 125-18 620 4 7.5
VariA 125-23 620 4 11

Nominal diameter	DN 125
Overall length	620 mm
Flanged connection	PN 16
Max. operating pressure	10 bar
Ambient temperature	0°C ... +40°C
Medium temperatures RED	+15°C ... +140°C
Medium temperatures GREEN 2	-20°C ... +90°C
Glycol proportion RED	≤25%
Glycol proportion GREEN 2	≤50%

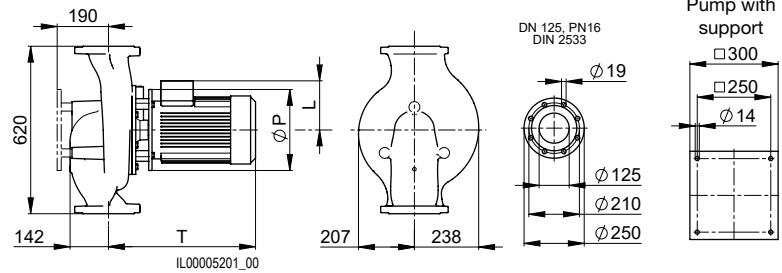

Type	T	P	L	Weight	Motor
VariA 125-12.5 620 4 4	485	250	149	118.5 kg	112M
VariA 125-15 620 4 5.5	510	300	182	132.0 kg	132S
VariA 125-18 620 4 7.5	545	300	182	143.0 kg	132M
VariA 125-23 620 4 11	625	350	200	177.0 kg	160M

Electrical data
VariA 125-12.5 620 4 4

Absorbed power P_2	4.00 kW
Nominale stroom	8.30 A

VariA 125-15 620 4 5.5

Absorbed power P_2	5.50 kW
Nominale stroom	11.10 A

VariA 125-18 620 4 7.5

Absorbed power P_2	7.50 kW
Nominale stroom	14.90 A

VariA 125-23 620 4 11

Absorbed power P_2	11.00 kW
Nominale stroom	22.00 A
Efficiency class	IE3
Protection type	IP55
Insulation class	F
Voltage / frequency	3x400V / 50 Hz
Motor protection	CTP 150°C
Speed	1450 1/min

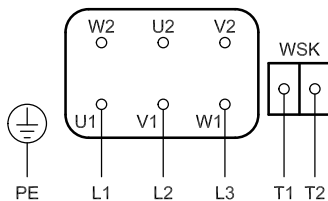
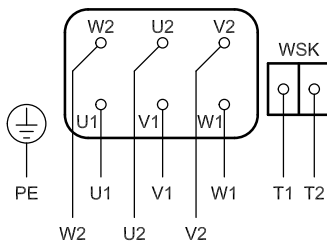
Connction diagram
Direct start-up

Y/Δ-start-up

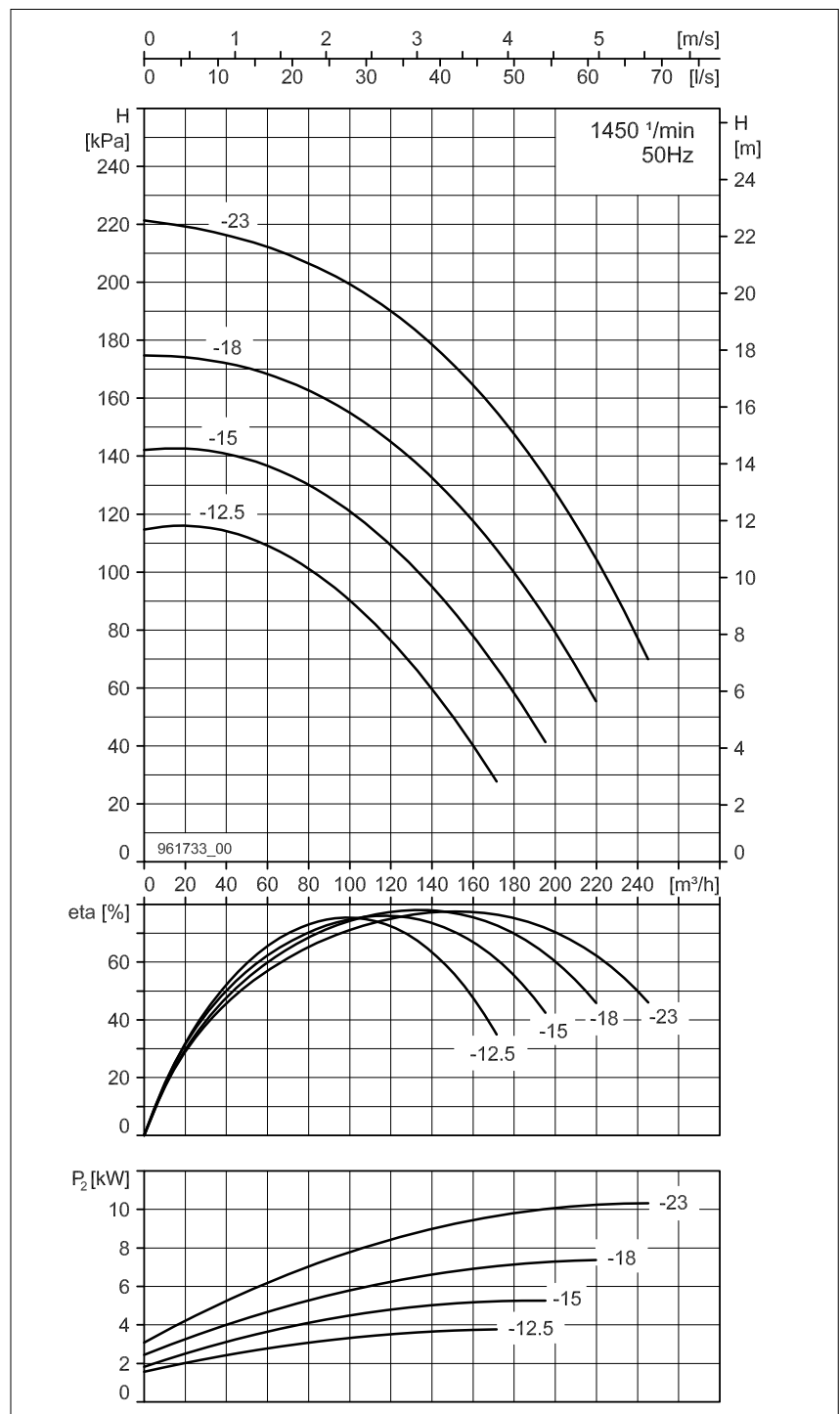
VariA... RED PN 16 without support
Art. No.

VariA 125-12.5 620 4 4	2210600150
VariA 125-15 620 4 5.5	2210610150
VariA 125-18 620 4 7.5	2210620150
VariA 125-23 620 4 11	2210630150



VariA 150-11.5 750 4 5.5

VariA 150-13.5 750 4 7.5

VariA 150-17 750 4 11

VariA 150-22 750 4 18.5

Nominal diameter	DN 150
Overall length	750 mm
Flanged connection	PN 16
Max. operating pressure	10 bar
Ambient temperature	0°C ... +40°C
Medium temperatures RED	+15°C ... +140°C
Medium temperatures GREEN 2	-20°C ... +90°C
Glycol proportion RED	≤25%
Glycol proportion GREEN 2	≤50%

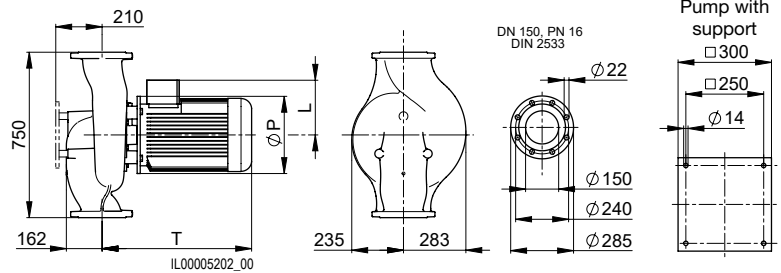

Type	T	P	L	Weight	Motor
VariA 150-11.5 750 4 5.5	520	300	182	168.0 kg	132S
VariA 150-13.5 750 4 7.5	555	300	182	179.0 kg	132M
VariA 150-17 750 4 11	635	350	200	202.0 kg	160M
VariA 150-22 750 4 18.5	678	350	248	217.0 kg	180M

Electrical data

VariA 150-11.5 750 4 5.5

Absorbed power P ₂	5.50 kW
Nominale stroom	11.10 A

VariA 150-13.5 750 4 7.5

Absorbed power P ₂	7.50 kW
Nominale stroom	14.90 A

VariA 150-17 750 4 11

Absorbed power P ₂	11.00 kW
Nominale stroom	22.00 A

VariA 150-22 750 4 18.5

Absorbed power P ₂	18.50 kW
Nominale stroom	37.30 A

Efficiency class	IE3
Protection type	IP55
Insulation class	F
Voltage / frequency	3x400V / 50 Hz
Motor protection	CTP 150°C
Speed	2900 1/min

Connction diagram

Direct start-up

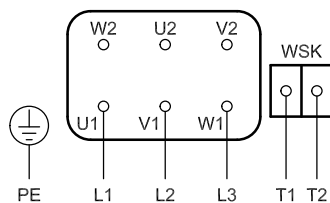

Y/Δ-start-up

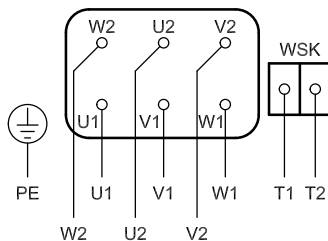

VariA... RED PN 16 without support

VariA...	Art. No.
VariA 150-11.5 750 4 5.5	2210640150
VariA 150-13.5 750 4 7.5	2210650150
VariA 150-17 750 4 11	2210660150
VariA 150-22 750 4 18.5	2210670150

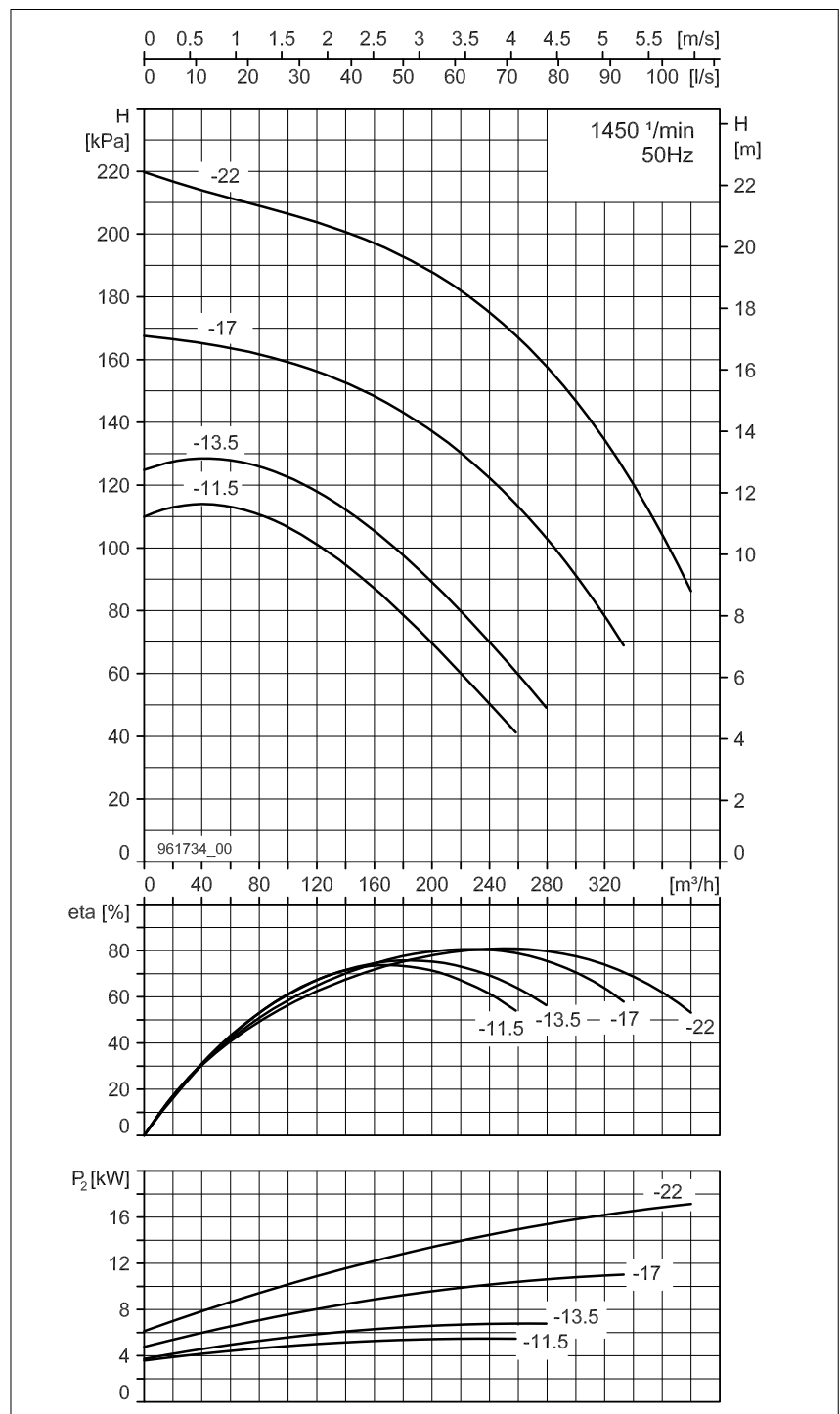

Datasheets

6.1 NPSH

VariA 32-x 190 4...

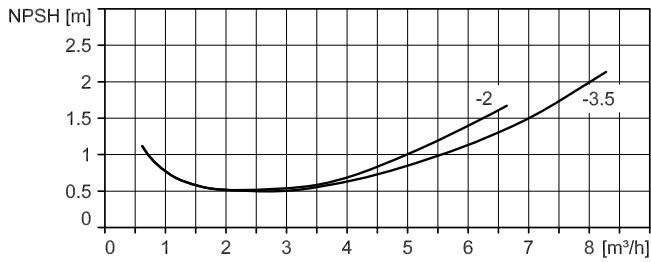

VariA 40-x 340 2...

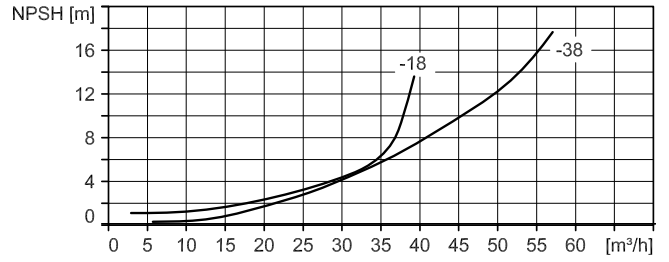

VariA 32-x 190 2...

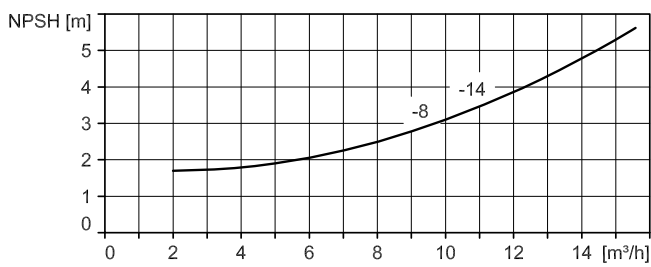

VariA 50-x 270 4 ...

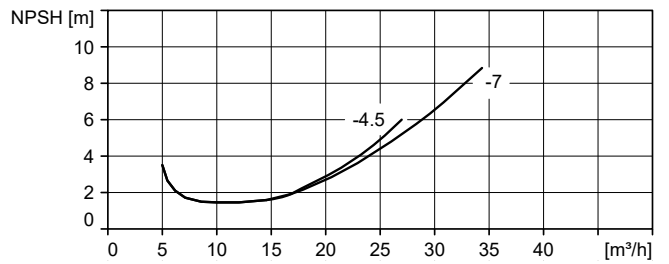

VariA 40-x 250 4...

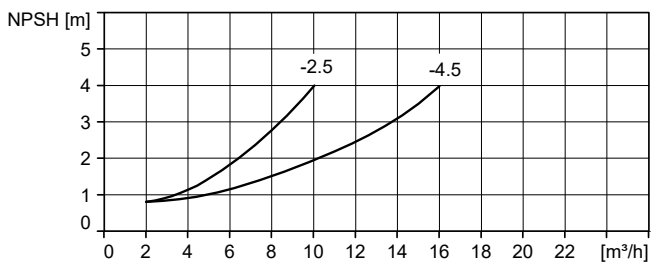

VariA 50-x 440 4 ...

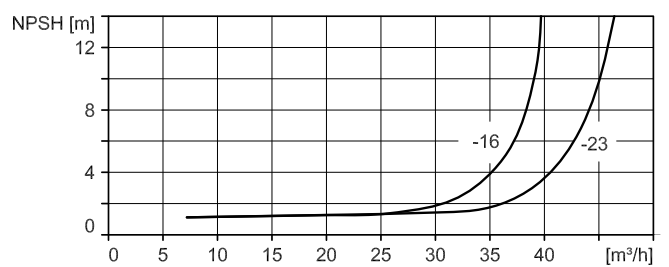

VariA 40-x 440 4...

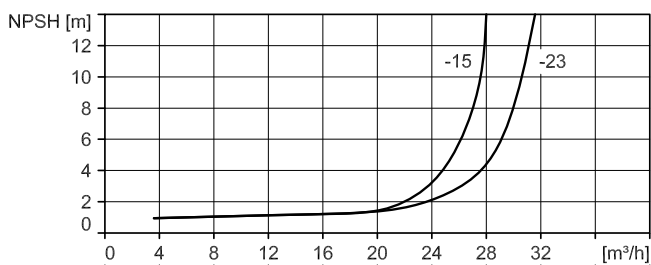

VariA 50-x 270 2 ...

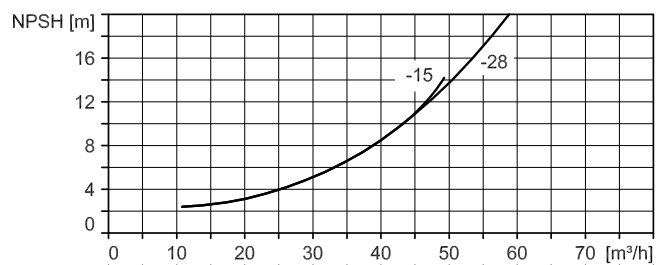

VariA 40-x 250 2 ...

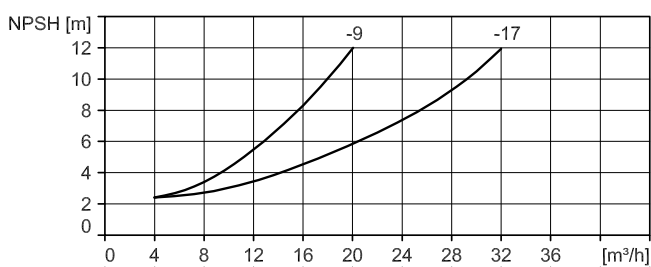

VariA 65-x 340 4 ...

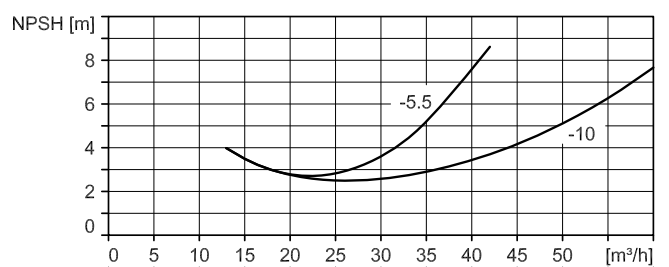

VariA 65-x 475 4...

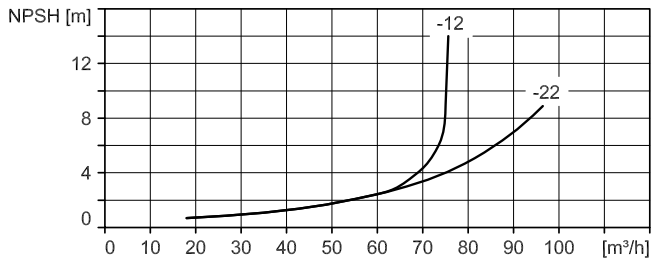

VariA 100-x 670 4...

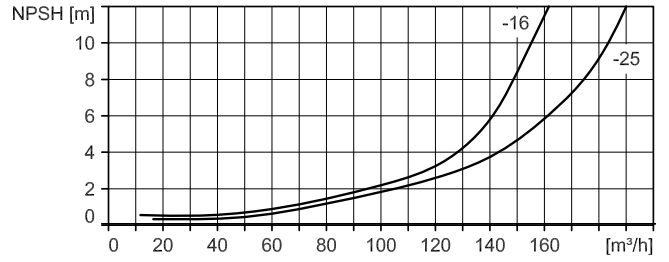

VariA 65-x 340 2...

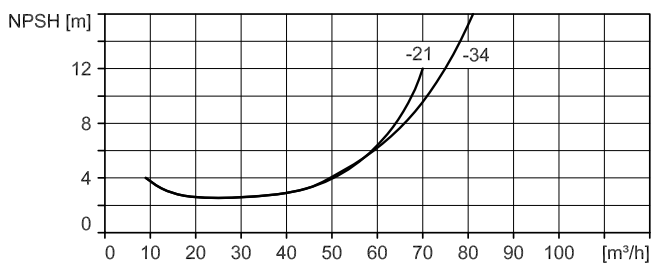

VariA 125-x 620 4 ...

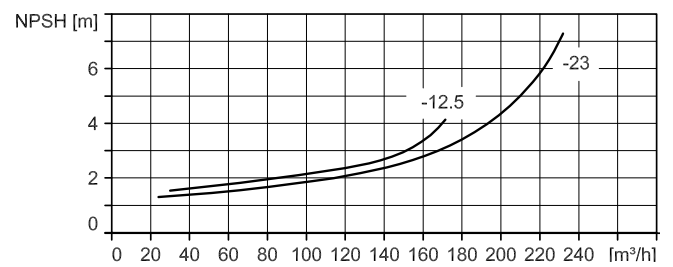

VariA 80-x 400 4...

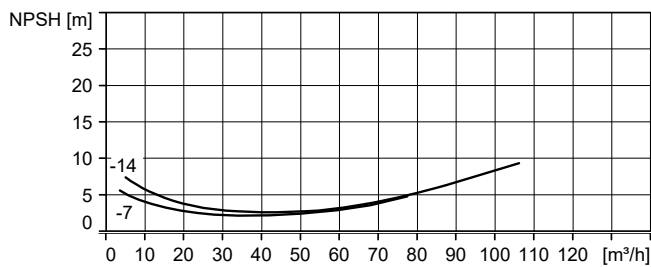

VariA 150-x 750 4 ...

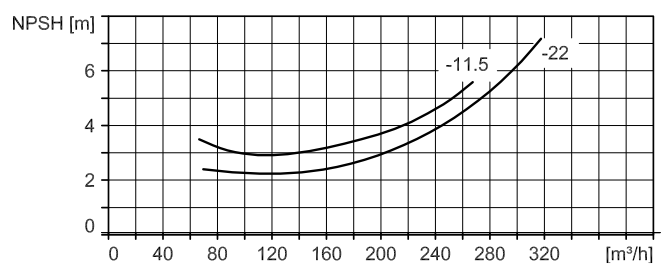

VariA 80-x 500 4...

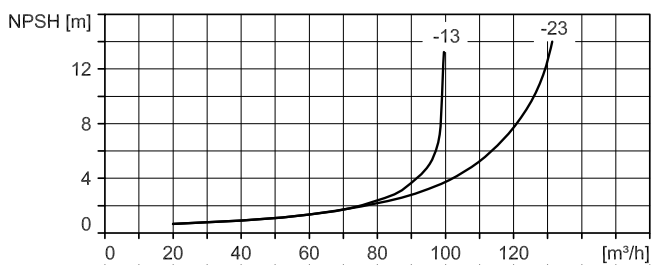

VariA 100-x 450 4 ...

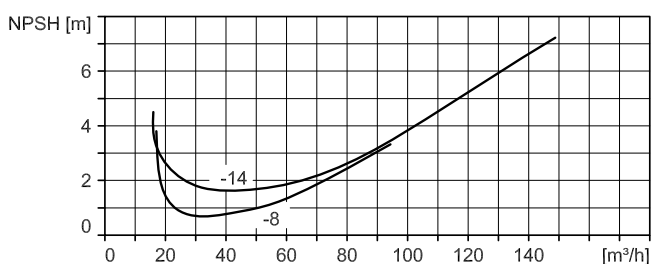



Biral AG

Südstrasse 10
CH-3110 Münsingen
T +41 31 720 90 00
info@biral.ch
www.biral.eu

Moving people and elements

